

Orano Canada Inc.

McClellan Lake Operation

Preliminary Decommissioning Plan and Financial Assurance

Version 10

February 2026

OPI Confidential

Orano Canada Inc.



Land Acknowledgement

Homeland of the Denesuline, Cree, and Métis peoples - past, present, and future.

The McClean Lake Operation, a uranium mine and mill facility, is located in northeastern Saskatchewan, Canada on Treaty 10 and on the Homeland of the Métis.

Approval for Use

Editor: [Redacted] Civil/Geotechnical Engineer
Name Title

Reviewer: [Redacted] Manager, Safety, Health,
Environment and Regulatory
Name Title

Approver: [Redacted] Vice President Safety, Health,
Environment and Regulatory
Name Title

History of Revisions

Version #	Date	Details of Revision
Version 1	March 1996	Initial document submitted to cover JEB mining phase only
Version 1.1	March 1997	Document updated to draft plans for future site decommissioning. No associated agreement reached on financial assurance.
Version 2	April 1999	Document updated to include developments prior to mill expansion required for Midwest and Cigar Lake ore processing.
Version 3	September 2004	Document updated to include operational aspects which had progressed beyond the environmental assessment process and expected to start within the next licensing period, assumed to be five years in duration. These include mining of Sue A and B ore bodies, mill expansion and deposition of Cigar Lake tails into the JEB TMF.
Version 3 Addendum	March 2005	Addendum added to main document to address issues raised by Saskatchewan Environment and the Canadian Nuclear Safety Commission upon regulatory review of Version 3, September 2004.
Version 4	April 2005	Document updated to incorporate the Addendum to Version 3. Scope of operational aspects was also expanded to include mining and waste rock disposition associated with the Sue E ore body and the Mining Equipment Development Area.
Version 5	January 2008	Document updated to incorporate mining and waste rock disposition associated with the Caribou project [Now called Sue F], the expansion of JEB Camp, and changes to the TMF section stemming from 2006 Agency acceptance of the TOVP follow-up program validation report.
Version 6	September 2008	Document updated to incorporate decommissioning of the Midwest site.

Version #	Date	Details of Revision
Version 7	January 2009	Document updated to address issues raised by the Canadian Nuclear Safety Commission and the Saskatchewan Ministry of Environment in their regulatory review of Version 6, September, 2008. The key changes made to the document include the removal of the hydraulic cage from the decommissioning cost estimate, the addition of a 2 year Care and Maintenance section and cost estimate, a reduction in the costs for the Midwest site due to progressive reclamation conducted in 2008, an update of the financial assurance and the addition of a decommissioning plan and cost estimate for the Caribou mining project [Now called Sue F mining project]. For more details please refer to the appropriate planning envelope or Section 5 "Financial Assurance".
Version 7, Rev. 2	October 2009	Document updated to address issues raised by the Canadian Nuclear Safety Commission and the Saskatchewan Ministry of the Environment in their regulatory review of Version 7, January 20, 2009. The key modifications include the addition of a cost development section with sources for decommissioning cost rates (Appendix B), a minor increase in labour rates from \$31/hr to \$33/hr, minor adjustments to the equipment rental rates in Appendix B, removal of the Caribou Project [now called Sue F mining project] from the financial assurance due to the suspension of the project, updating of the financial assurance and reformatting of the cost tables.
Version 7, Rev. 3	March 2010	At the request of CNSC on February 8, 2010, details have been added to the above January and October, 2009 "History of Revisions" sections regarding specific changes made to the Versions 6 and Version 7 documents. Additional text has been added to this table to provide more clarity regarding the changes made to the document over the last 14 months; however, the currently approved PDP and FA remain unchanged.
Version 8	November 2014	Document has been updated to include decommissioning of the expanded McClean Lake Mill and future water treatment requirements. Adjustments to the cost estimate tables have been made to reflect current labour and equipment rates. Updates to the document also considered requirements and guidance provided by Canadian Standards Association N294-09, Decommissioning of Facilities Containing Nuclear Substances.

Version #	Date	Details of Revision
Version 8, Rev. 1	November 2015	Document updated in response to comments generated from the Canadian Nuclear Safety Commission and the Saskatchewan Ministry of the Environment in their regulatory review of Version 8. Key modifications include the increase in contingency rates to align with Regulatory Guide G- 206 guidance, clarifying where administrative and regulatory approval costs are captured, updating reference documents where newer versions were available, and correcting formatting errors in the main document.
Version 8, Rev. 2	March 2016	Document updated for clarification of administrative costs, contingency allowance, and hazardous materials management. Additional regulatory, administrative, and hazardous materials cleanup costs have been applied to the Financial Calculations provided in Appendix B. Section 1.6 provides rationale for use of a Grade B cost estimate as defined in CNSC Regulatory Guide G-206. A concordance table relating the sections of the financial cost estimate to G-206 guidance is provided as Appendix F.
Version 8, Rev. 3	October 2016	Replace the financial letters of guarantee and incorporate the Saskatchewan Ministry of Environments confirmation email which provided record of nine (9) separate financial instruments held by the Ministry into Appendix D.
Version 8 Rev. 4	May 2017	Replace the confirmation email which provided the record of nine (9) separate financial instruments held by the Ministry with the actual financial letters of guarantee into Appendix D.
Version 9	2020	PDP updated to include closure vision (Section 2.1) and revised decommissioning criteria. Adjustments to the cost estimate tables have been made to reflect current labour and equipment rates. Updates to the document also considered requirements and guidance provided by Canadian Standards Association N294-09, Decommissioning of Facilities Containing Nuclear Substances.
Version 9 Rev. 1	2022	<p>Updated to reflect change in ownership</p> <p>Updated to integrate necessary response to comments received from the CNSC and SMOE review of draft Version 9</p> <ul style="list-style-type: none"> • Inclusion of language regarding Sask Power's responsibility to decommissioning power lines • Fixed minor typos • Updated outdated references • Updated figure numbering • Update to Appendix D – Financial Instruments • Update to Appendix E – N294 Concordance Table • Update to Appendix F – G-206 Concordance Table

Version #	Date	Details of Revision
Version 10	2026	<ul style="list-style-type: none"> • Update to JEB Tailings Management Facility closure strategy and associated costs. • Update to McClean Mining Area in Planning Envelope #8 cost estimate to account for expansion in 2025 • Update to entire financial assurance to reflect current unit rates, labour and monitoring costs. • Update to Regulatory Concordance tables in Appendix E, F and G.

Table of Contents

1	Introduction.....	1-1
2	Before, During, and After Mining	2-1
2.1	McClellan Lake Operations	2-1
2.1.1	Site Overview	2-1
2.2	Orano’s Commitment to Decommissioning	2-1
2.2.1	Cluff Lake Experience	2-2
2.3	Post-Closure Vision and Land Use.....	2-3
2.4	Closure Principles	2-4
2.5	Closure Life Cycle Planning.....	2-4
2.5.1	Temporal Scope.....	2-4
2.5.2	Ongoing Review and Revision.....	2-4
2.5.3	Detailed Decommissioning Plan at Closure.....	2-5
2.5.4	Engagement at Closure	2-5
2.5.5	Socioeconomic Transition at Closure	2-6
2.5.6	Supporting Documents.....	2-6
3	Approvals, Standards, and Requirements	3-1
3.1	Licensee and Project Ownership	3-1
3.2	Current Licenses and Approvals.....	3-1
3.3	Regulatory and Best Practice Framework	3-2
3.3.1	Provincial and Federal Coordination.....	3-2
3.3.2	Provincial Regulatory Framework	3-2
3.3.3	Federal Regulatory Framework	3-3
3.3.4	Best Practice and International Guidance.....	3-4
3.4	Financial Assurance	3-4
4	Decommissioning Strategy	4-1
4.1	Decommissioning Objectives and Success Criteria	4-1
4.2	Knowledge Base	4-2
4.2.1	Receptor Water Bodies	4-3
4.2.2	Land Use and Diet	4-3
4.2.3	Tailings Optimization and Validation Program	4-3
4.2.4	Groundwater Modeling.....	4-4
4.2.5	Pit Lakes	4-4
4.2.6	Sink Reservoir	4-5

4.3	Long-Term Institutional Control	4-6
4.4	Progressive Decommissioning	4-6
4.5	Uncertainty and Contingency.....	4-6
4.6	Operational Management during Decommissioning.....	4-7
4.6.1	Quality Management	4-7
4.6.2	Environmental Protection Program.....	4-7
4.6.3	Radiation Protection.....	4-8
4.6.4	Health and Safety.....	4-8
4.6.5	Training	4-9
4.6.6	Emergency Response.....	4-9
4.6.7	Site Security	4-9
4.6.8	Operational Record Keeping.....	4-9
5	Preliminary Decommissioning Work Plan.....	5-10
5.1	Post-Operational Conditions.....	5-11
5.1.1	Shut-down Process	5-11
5.1.2	Detailed Decommissioning Planning	5-13
5.2	Administrative and Project Management Costs during Decommissioning.....	5-15
5.3	Decommissioning Activities by Planning Envelope	5-15
5.3.1	Planning Envelope # 1: JEB Mining Area	5-16
5.3.1.1	Description	5-16
5.3.1.2	Preliminary Decommissioning Approach	5-18
5.3.2	Planning Envelope # 2: McClean Lake Mill and Associated Facilities.....	5-20
5.3.2.1	Description	5-20
5.3.2.2	Preliminary Decommissioning Approach	5-23
5.3.3	Planning Envelope # 3: JEB Tailings Management Facility.....	5-28
5.3.3.1	Description	5-28
5.3.3.2	Preliminary Decommissioning Approach	5-29
5.3.3.3	Final JEB TMF Configuration	5-33
5.3.3.4	Tailings Contingency.....	5-33
5.3.4	Planning Envelope # 4: Camp Area.....	5-34
5.3.4.1	Description	5-34
5.3.4.2	Preliminary Decommissioning Approach	5-35
5.3.5	Planning Envelope # 5: Sue Mining Area	5-36
5.3.5.1	Description	5-36
5.3.5.2	Preliminary Decommissioning Approach	5-37
5.3.6	Planning Envelope # 6: Sue Site Facilities	5-40
5.3.6.1	Description	5-40
5.3.6.2	Preliminary Decommissioning Approach	5-41

5.3.7	Planning Envelope # 7: Sink/Vulture Treated Effluent Management System.....	5-43
5.3.7.1	Description	5-43
5.3.7.2	Preliminary Decommissioning Approach	5-43
5.3.8	Planning Envelope # 8: Ancillary Facilities and McClean Lake Mining Site	5-44
5.3.8.1	Description	5-44
5.3.8.2	Preliminary Decommissioning Approach	5-44
5.3.9	Planning Envelope # 9: Midwest Site.....	5-47
5.3.9.1	Description	5-48
5.3.9.2	Preliminary Decommissioning Approach	5-48
5.3.10	Planning Envelope # 10: Sue F Mining Area	5-50
5.4	Post-Decommissioning and Institutional Control	5-50
5.4.1	Post-Decommissioning Monitoring	5-50
5.4.2	Institutional Control program.....	5-51
5.5	Sequencing of Decommissioning	5-51
5.5.1	Conceptual Decommissioning Schedule	5-51
6	Financial Assurance Summary	6-1
7	Progressive Reclamation and Decommissioning.....	7-1
7.1	Progressive Reclamation Activities.....	7-1
7.2	Progressive Decommissioning Activities	7-1
7.3	Progressive Decommissioning that Achieves Final Closure Criteria.....	7-2
8	References	8-1
	Appendix A Figures	A-1
	Appendix B Financial Calculations.....	B-1
	Appendix C PDP History.....	1
	Appendix D: Financial Instruments	3
	Appendix E: CSA N294-19 Concordance Table	4
	Appendix F: REGDOC-2.11.2 Concordance Table	5
	Appendix G:REGDOC-3.3.1 Concordance Table	1
	Appendix H: Progressive Reclamation – Closure Documentation	1

Acronyms and Abbreviations

Term	Definition
AECEB	Atomic Energy Control Board
ALARA	As low as reasonably achievable
CCD	Counter Current Decantation Circuit
CCME	Canadian Council of Ministers of the Environment
CNSC	Canadian Nuclear Safety Commission
COPCs	Constituents of potential concern
CSR	Corporate Social Responsibility
CX	Ammonium Sulphate Crystallization Plant
DDP	Detailed Decommissioning Plan
EA	Environmental Assessment
EAB	Environmental Assessment Branch
EC	Environment Canada
EEM	Environmental effects monitoring program
EHS	Environment Health and Safety
EMP	Environmental Monitoring Program
EMS	Environmental Management System
ERAP	Emergency Response Assistance Plan
GISTM	Global Industry Standard on Tailings Management
ICMM	International Council on Mining and Metals
ICP	Institutional Control Program
IMS	Integrated Quality Management System
ISO	International Organization for Standardization
JEB site	The area containing the JEB TMF, JEB waste stockpile, ore pad, mill and office complex and the associated outbuildings.
JEB WTP	JEB Water Treatment Plant
mASL	Meters Above Sea Level
MMER	Metal Mining Effluent Regulations
SEQG	Saskatchewan Environment Quality Guidelines
SMOE	Saskatchewan Ministry of Environment
ORANO	Orano Canada Inc.
PDP	Preliminary Decommissioning Plan
PMP	Probable Maximum Precipitation
PSPs	permanent sampling plots
S/V TEMS	Sink/Vulture Treated Effluent Management System
SABRE	Surface Access Borehole Recovery Extraction
SSWQO	Saskatchewan Surface Water Quality Objective
TID	Technical Information Document

Term	Definition
TMF	Tailings Management Facility (used to describe the McClean Lake Operation configuration)
TOVP	Tailings Optimization and Validation Program
WTP	Water Treatment Plant

1 Introduction

Early consideration and iterative planning for mine decommissioning positions Orano to deliver a positive mine legacy by addressing the three pillars of sustainable development - environment, community, and economics.

The purpose of this decommissioning plan is to outline the process to be undertaken to safely and efficiently decommission the McClean Lake Operation located in northeastern Saskatchewan. The plan aims to ensure that decommissioning is:

- aligned with Orano values, corporate policy, and community visions for post-closure land use,
- compliant with regulations and incorporates best practice,
- establishes a framework for relinquishment and long-term monitoring and maintenance, and
- provides a basis for the determination of a financial assurance.

The preliminary decommissioning plan is structured in six sections as follows.

Section 2: provides the context or foundations for the decommissioning plan including a brief history of the land where the McClean Lake Operation sits, an overview of the McClean Lake Operation, Orano commitment to decommissioning, Company and community visions for post-closure land use, and the relationship of the PDP to mine life stage.

Section 3: outlines the project ownership, regulatory approvals, key supporting documents, standards, requirements, and best practice considered in the development of the decommissioning plan.

Section 4: outlines the decommissioning strategy including closure objectives and success criteria, the required knowledge base, and operational management.

Section 5: contains the decommissioning work plan, including post-closure considerations, from which the financial assurance is estimated.

Section 6: provides a summary of the estimated financial assurance.

Section 7: summarizes progressive closure and details aspects of progressive closure proposed to achieve final closure success criteria.

2 Before, During, and After Mining

2.1 McClean Lake Operations

2.1.1 Site Overview

The McClean Lake Operation facilities are situated on a surface lease governed by the Province of Saskatchewan.

The McClean Lake Operation includes the mining and milling of uranium and the treatment and management of associated waste rock, tailings, process water, and other waste (e.g., reagent, camp waste). The operation is situated in nine (9) areas or planning envelopes (Figures 1 - 9):

1. JEB Mining Area;
2. McClean Lake Mill and Associated Facilities;
3. JEB Tailings Management Facility (TMF);
4. Permanent Camp Area;
5. Sue Mining Area;
6. Sue Site Facilities;
7. Sink/Vulture Treated Effluent Management System (S/V TEMS);
8. Ancillary Facilities and McClean Mining Site; and
9. Midwest Site.

Access to the McClean Lake Operation is via an all-weather road that is part of the provincial highway system with access roads to the Sue, JEB, S/V TEMS, and Midwest sites.

2.2 Orano's Commitment to Decommissioning

Orano is committed to sustainably decommissioning its operations and plans for this remediation work at the outset of a project. As an International Council on Mining and Metals (ICMM) member, Orano reports on Principle 6.1 "*Plan and design closures in consultation with relevant authorities and stakeholders concerned, implement measures to address closure-related environmental and social aspects, and make financial provision to enable agreed closure and post-closure commitments to be realized*" at the subsidiary and business unit level.

Globally, Orano has been involved in over 160 decommissioning and dismantling projects, including 64 nuclear power plants worldwide. Orano Canada decommissioned the Cluff Lake Mine – the first uranium site of its era to be decommissioned under modern standards. Our commitment to decommissioning is so fundamental that we consider decommissioning within our portfolio of expertise.

2.2.1 Cluff Lake Experience

The Cluff Lake Project, a decommissioned mine site, located in northwestern Saskatchewan on Treaty 8 territory and within the homeland of the Métis. The closest community to Cluff Lake is Fort Chipewyan, Alberta about 100 km to the northwest although there is no direct road link. The closest communities by road are Clearwater River Dene Nation and La Loche, Saskatchewan about 250 km to the south. The mine site is located approximately 900 km north of Saskatoon, Saskatchewan.

During operations, 1980 to 2002, the Cluff Lake Project produced uranium (28 M kg U₃O₈) and gold. The Cluff Lake Project was owned, operated, and decommissioned by the same company; directly managed by Orano throughout its entire history and has never been abandoned.

Decommissioning of the mine and all its associated structures was subject to an environmental assessment that lasted several years (2000 to 2004) with review from federal and provincial regulatory agencies and the public. The goals for decommissioning were to produce a site that would be safe and stable for traditional land use now and in the very long-term, with only a small fingerprint of past mining activity. The key objective was to remove, minimize, control potential contaminant sources with designs for in-situ waste management at closure.

Decommissioning works were largely completed by 2006, e.g. buildings were demolished, water was treated, mined out pits were flooded to create pit lakes, engineered covers were placed on the tailings management area and waste rock pile, and hundreds of thousands of trees were planted. In 2013, access to the site became unrestricted and Orano full-time occupation ended, demonstrating that mining can indeed be a temporary use with return to safe traditional land uses. In 2023, the site was transferred into the provincial Institutional Control Program.

Lessons learned from the Cluff Lake experience that have been incorporated into McClean Lake decommissioning planning include:

- Sustainable mine closure is a shared endeavour – industry, government, community. Throughout operations, Orano facilitated safe travel through the site for community members travelling along the Semchuck Trail, a travel route that existed prior to mine development. At closure, Orano, provincial regulators, and the Flett family worked together to formally separate and recognize a traditional trap line and camp location within the former mine site surface lease. The same collaborative approach is reflected in the Closure Vision, Life Cycle and Engagement Sections.
- Measurable Success Criteria. Cluff Lake decommissioning objectives, established in the decommissioning environmental assessment, varied in specificity ranging from surface water quality objectives to the phrase “aesthetically acceptable”. The McClean Lake Operation PDP has differentiated

the terms 'decommissioning objectives' from 'success criteria' and, through Detailed Decommissioning Planning, will endeavor to create success criteria with strong shared expectations for when success has been achieved. See Section 4.1.

- Tailings Optimization and Validation Program (TOVP). The Cluff Lake decommissioning risk assessment required the use of conservative assumptions, sensitivity analysis, and extensive follow up programs related to the decommissioning of the tailings management area. The confidence with McClean Lake tailings source terms and contaminant transport are materially improved compared to Cluff Lake given ongoing studies under the TOVP. See Section 4.2.3 – Knowledge Base – Tailings.
- The capacity and stability of wetlands to sequester and retain Contaminants of Potential Concern (COPCs). The Island Lake fen successfully sequestered and retained COPCs from treated effluent providing a passive, effective, long-term environmental protection downstream of the closed mine site. Consideration for existing and/or engineered wetlands may play an important role in the closure of the McClean Lake Operation.
- Delay in physical decommissioning following the end of operations. Although the Cluff Lake closure was planned and Detailed Decommissioning Planning was initiated prior to the end of operations, there was a two-year delay between the end of operations and the start of physical decommissioning. The McClean Lake Operation, unlike the Cluff Lake Operation, is unlikely to require an environmental assessment specific to decommissioning (see Section 2.5.3) thereby shortening the timeline to physical decommissioning. Although the intention is to avoid any delay in physical decommissioning following closure, the McClean Lake Operation PDP conservatively includes a 2-year delay. See Section 5.1.
- Campaign Monitoring. The Cluff Lake site ceased full time presence in 2013, seven years after initial physical decommissioning. This allowed for safe, unrestricted access for traditional purposes throughout the remainder of transitional phase monitoring. Transitional phase monitoring was completed in quarterly campaigns. The transition to campaign monitoring is also proposed in the McClean Lake Operation PDP. See Section 5.4.1.

2.3 Post-Closure Vision and Land Use

Since development and throughout operations, the guiding closure vision for the McClean Lake Operation is safe, casual traditional land uses (e.g., trapping, hunting, fishing, camping). Engagement to date supports this post closure land use – the importance of country food to local diets and the importance of continued land use to maintain and connect to culture and identity are recorded in engagement records. Local and regional diet and land use studies, led by the Athabasca Joint Environment Sub-Committee, further support this closure vision. The post-closure vision of traditional land use is compatible with relinquishment, i.e., transfer into provincial institutional control.

It is important to note that decommissioned mine sites will have residual risks. Residual risks will be identified, and mechanisms will be put in place to manage those identified risks. Examples include institutional control, long-term monitoring and maintenance, restricted land uses listed (e.g., groundwater wells for drinking water,

exploration in mine waste) but the goal will be to minimize land use restrictions and confidently allow for safe, casual traditional land use.

Engagement on alternative post-closure use(s) will increase near time of closure to reflect the current views, considering that desires of stakeholders can evolve over time.

2.4 Closure Principles

To achieve the closure vision of a generational positive legacy and casual traditional land use, the plan is guided by the following principles:

- reclaimed landscape is **safe** for human and non-human biota,
- reclaimed landscape is **chemically and physically/geotechnically stable**,
- **self-sustaining landscape** where the area can reestablish following natural disturbances,
- execution of closure in ways that are **cost-effective** and efficient, and
- **control risk** to an acceptable level and minimize any potential constraints on future land use.

2.5 Closure Life Cycle Planning

Closure plans, including this one, are developed based on a current mine plan. Mine plans typically evolve over time, and, at any given time, there are usually several possible modifications to the mine plan under consideration.

2.5.1 Temporal Scope

This Preliminary Decommissioning Plan (PDP) and Financial Assurance (FA) is updated on a 5-year cycle. Historical revisions to the PDP and FA are included in the History of Revisions table at the beginning of this document and expanded upon in Appendix C. In line with lifecycle planning, this plan has been prepared for the McClean Lake Operation with consideration of planned activities within a 5-year period, to the end of 2030.

2.5.2 Ongoing Review and Revision

Orano is committed to periodically reviewing and updating the PDP as warranted by:

- changes in site conditions;
- changes to the proposed decommissioning objectives or strategy;
- advances in decommissioning technology;

- modifications to the facility;
- updated cost and funding information;
- revised regulatory requirements; and,
- revised records requirements.

It is recognized that future revisions to this PDP and FA will be required capture changes to future operations. Decommissioning requirements are considered at the design and planning stages of new site developments, and any new developments would be included in the PDP and FA calculation upon completion of construction. For example, this PDP version includes the decommissioning of additional facilities associated with the optimization of the JEB TMF to increase tailings storage capacity that were not included in the previous plan.

Orano is obligated to decommission the McClean Lake Operation at the end of its lifecycle and, approaching closure, this PDP will evolve into a Detailed Decommissioning Plan (DDP) that will provide detailed plans for regulatory approval prior to commencing final decommissioning activities.

2.5.3 Detailed Decommissioning Plan at Closure

Orano is committed to preparing a Detailed Decommissioning Plan (DDP) for regulatory approval prior to decommissioning, in advance of a scheduled shut-down of the McClean Lake Operation. The post-closure environmental impacts of the decommissioned McClean Lake Operation and Midwest properties have already been considered in environmental assessments; the application for a decommissioning license is not expected to trigger an environmental assessment (EA) under either the *Nuclear Safety and Control Act* or the *Impact Assessment Act*.

2.5.4 Engagement at Closure

As the McClean Lake Operation nears closure there will be more extensive community engagement initiatives regarding the Detailed Decommissioning Plan that may include designs, aesthetics, species of grass and trees for reclamation, decommissioning success criteria, monitoring updates, and others. Other topics may include the distribution of salvageable materials and equipment to interested communities or organizations.

During and after closure, monitoring, community updates, and likely a series of site tours will be provided to keep communities aware of decommissioning progress, success, and residual risks.

An Indigenous Engagement Plan as per CNSC REGDOC 3.2.2 will be developed to supplement the Public Information Plan and transition to Detailed Decommissioning Planning and activities, as required. Engagement costs are included in Table B1.9 as part of the Regulatory Process and Engagement Fees.

2.5.5 Socioeconomic Transition at Closure

Engagement with concerned rightsholders and stakeholders, early and often, will be critical for a successful transition.

Over time, there can be local dependence on mining operations and Orano has worked to help local businesses build capacity for sustainable post-closure jobs and contracts with other industries across the north. At closure, social transition activities will be well under way, with the community already mobilized and implementing their community development plan, with limited need for ongoing support from mining companies.

2.5.6 Supporting Documents

Orano has evaluated the post-closure environmental risk of the site through the environmental assessment process and commits to periodic updates to the environmental risk assessment and the PDP. A list of relevant environmental assessments which form the licensing basis for the McClean Lake Operation are provided in Section G.1 of the License Conditions Handbook (CNSC 2024). The environmental risk assessment for the McClean Lake Operation was most recently updated in the 2025 Environmental Performance Technical Information Document Volume 2 (EP TID Vol. 2; Orano 2025b).

The McClean Lake Operation Facility Description Manual (FDM; Orano 2022) provides a thorough description of the facilities which comprise the McClean Lake Operation. Similarly, a thorough description of the biophysical environment is provided within the 2025 Environmental Performance Technical Information Document (EP TID; Orano 2025a and Orano 2025b).

Current site facilities are described by the McClean Lake Operation Facility Description Manual (FDM; Orano 2022). The FDM includes a description of the current and proposed mining and milling operations schedule and detailed descriptions of the facilities comprising the JEB, Sue, and Midwest sites. The FDM is revised periodically to reflect changes to the McClean Lake Operation and is managed through the Integrated Management System (IMS; Orano 2025c).

The 2025 EP TID Vol. 2 (Orano 2025b) provides an update of predictive modelling for air, surface water, sediment quality and ecological and human health risks for a 100-year period based on operational and decommissioning plans. The 2025 EP TID includes validation of the 2016 environmental modelling. Long-term performance of the decommissioned JEB TMF is modelled within the McClean Lake Operation Tailings Management TID (Orano 2025e). Preliminary designs for JEB TMF closure within this document are consistent with those used as model inputs generating the results within the McClean Lake Operation Tailings Management TID. Clean waste rock is suitable for purposes such as on-site construction and future decommissioning activities. Clean waste rock piles are considered permanent, and their reclamation is considered within the scope of future site decommissioning activities (Orano 2023d).

The groundwater modelling and the risk assessment are updated periodically to meet the standards of CSA N288.7 and CSA N288.6, respectively, and ensure that we are planning for decommissioning throughout

operations by routinely validating that decommissioning designs are technically feasible to achieve the stated decommissioning performance objectives.

The McClean Lake Operation Public Information Program (Orano 2025d) outlines the company commitment to engage and inform stakeholders about information related to the health, safety, and security of persons and the environment at the McClean Lake Operation – now and into the future. engagement on decommissioning during the operations phase of the project typically includes the following topics: early planning for decommissioning / operating with eventual decommissioning in mind, legislated obligation for financial assurance and Orano compliance, progressive decommissioning, and eventual closure vision – safe for traditional land use. Orano must understand and consider past, current, and potential future land uses as informed by key stakeholders.

3 Approvals, Standards, and Requirements

This PDP and corresponding FA have been prepared considering provincial, federal, and international documents relevant to decommissioning, reclamation, and financial assurance. Current industry best management practices applied at the McClean Lake Operation are described below.

3.1 Licensee and Project Ownership

Orano Canada Inc. (Orano), is the majority owner and operator of the McClean Lake Operation that includes the Midwest Project. Ownership of the McClean Lake Operation and the Midwest Project is held through joint venture agreements as follows:

	McClean Lake Joint Venture	Midwest Joint Venture
Orano Canada Inc.	77.5%	74.83%
Denison Mines Corp.	22.5%	25.17%

Orano Canada Inc., with headquarters in Saskatoon, SK is located at:

Orano Canada Inc.
100-833 45th Street West
Saskatoon, SK S7L 5X2

3.2 Current Licenses and Approvals

Orano holds the following approvals and licenses for the McClean Lake Operation:

Issuer	License or Approval Number	Issue Date	Expiry Date
SMOE	PO24-012	January 31, 2024	October 31, 2029
CNSC	UML-MINEMILL-McCLEAN.02/2027	July 1, 2017 (revised January 13, 2022)	June 30, 2027

Approvals and licenses are valid for the periods indicated above unless suspended, amended, revoked, or replaced. Decommissioning planning covers all licensed activities.

3.3 Regulatory and Best Practice Framework

3.3.1 Provincial and Federal Coordination

Uranium mining companies in Saskatchewan are required by the Saskatchewan Ministry of Environment (SMOE) and the Canadian Nuclear Safety Commission (CNSC) to develop decommissioning and reclamation plans, including financial surety. These requirements are stated in Section 12 of the *Mineral Industry Environmental Protection Regulations*, 1996 and Section 3 of the *General Nuclear Safety and Control Regulations* (Section 3(1)(l) requires a description of proposed financial guarantee).

The CNSC and SMOE have entered into a Memorandum of Understanding (MOU), dated May 2024, to collaborate on the implementation, application and administration of regulations and requirements related to decommissioning and reclamation, including the provision of financial assurances, for uranium mining and milling facilities in Saskatchewan. This document is a common report on the technical description and the cost evaluation of the future decommissioning activities on which the CNSC and SMOE will make independent approval decisions. The cost estimates provide the basis for a financial assurance, which would be used by the landowner (i.e., the province of Saskatchewan) in the event the mining company was unable to carry out its commitment to decommission and reclaim the mine site.

3.3.2 Provincial Regulatory Framework

The relevant provincial documentation reviewed for guidance and to ensure compliance includes:

- *The Environmental Management and Protection Act*, 2010 and Regulations, principally the Mineral Industry Environmental Protection Regulations, 1996;
- *The Reclaimed Industrial Sites Act* and the Reclaimed Industrial Sites Regulations;
- Northern Mine Decommissioning and Reclamation Guidelines (SMOE 2008);
- The Hazardous Substances and Waste Dangerous Good Regulations;
- *The Saskatchewan Employment Act*, Occupational Health and Safety Regulations, 2020 and The Mines Regulations, 2018;
- Saskatchewan Environmental Code, and adopted standards, including the Saskatchewan Environmental Quality Standards;
- Landfill Decommissioning and Reclamation (Closure) Guidance (SMOE 2021); and
- *Provincial Lands Act*, 2016 and Crown Resource Land Regulations, 2019.

3.3.3 Federal Regulatory Framework

The relevant federal documentation reviewed for guidance and to ensure compliance includes:

- *Nuclear Safety and Control Act* and Regulations, principally the General Nuclear Safety and Control Regulations, and the Uranium Mines and Mills Regulations;
- Metal and Diamond Mining Effluent Regulations;
- REGDOC 2.11.1 Waste Management, Volume I: Management of Radioactive Waste (CNSC 2021a);
- REGDOC 2.11.1 Waste Management, Volume II: Management of Uranium Mine Waste Rock and Mill Tailings (CNSC 2018a); (Applicable to new uranium mine or mill projects and/or to new waste management facilities at existing uranium mines and mills)
- REGDOC 2.11.1 Waste Management, Volume III: Safety Case for the Disposal of Radioactive Waste, Version 2 (CNSC 2021b);
- REGDOC 2.11.2 Decommissioning (CNSC 2021c);
- REGDOC 2.9.1 Environmental Protection: Environmental Principles, Assessments and Protection Measures, Version 1.2 (CNSC 2020);
- REGDOC-3.2.1 Public Information and Disclosure (CNSC 2018b);
- REGDOC-3.2.2 Indigenous Engagement (CNSC 2022);
- REGDOC 3.3.1 Financial Guarantees for Decommissioning of Nuclear Facilities and Termination of Licensed Activities (CNSC 2021d);
- CSA standard N294-19 Decommissioning of Facilities Containing Nuclear Substances (CSA 2019); and
- Canadian Environmental Quality Guidelines.

Concordance tables are included in the appendices that indicate where the information contained within this PDP and McClean Lake Operation supporting documents aligns with the requirements of the CNSC regulatory requirements: Decommissioning of Facilities Containing Nuclear Substances (Appendix E), Decommissioning (Appendix F); and Financial Guarantees for Decommissioning of Nuclear Facilities and Termination of Licensed Activities (Appendix G).

3.3.4 Best Practice and International Guidance

The uranium mining industry, supported by agencies such as the CNSC and the International Atomic Energy Agency (IAEA), continue to develop and implement procedures in environmental management that are regarded as industry best practices (IAEA 2010). These best management practices have been integrated into the design of permanent waste management facilities at the McClean Lake Operation in order to meet end-state objectives and achieve a safe state of closure. These facilities are summarized below and described further in Section 5.

- International Atomic Energy Agency (IAEA) Specific Safety Requirements No. SSR-5, Disposal of Radioactive Waste (IAEA 2011)
- IAEA Specific Safety Requirements No. SSG-23, The Safety Case and Safety Assessment for the Disposal of Radioactive Waste (IAEA 2012)
- IAEA Best Practice in Environmental Management of Uranium Mining (IAEA 2010)

Orano is a member of the International Council on Mining and Metals (ICMM). Membership in ICMM requires company commitment to 10 mining principles and nine position statements. This document was prepared in consideration of the following ICMM guidance documents:

- Integrated Mine Closure; Good Practice Guide, (ICMM 2019a);
- Financial Concepts for Mine Closure Guidance, (ICMM 2019b); and
- Closure Maturity Framework (ICMM 2022).

Global Industry Standard on Tailings Management (GISTM; ICMM 2020). Orano maintains compliance to the GISTM for the JEB TMF during operations. During the decommissioning phases, compliance to the GISTM will be maintained.

3.4 Financial Assurance

The purpose of the mine operator providing a financial assurance to the Government of Saskatchewan is to ensure that the government (i.e., taxpayer) is not burdened with the cost of decommissioning a mining facility. In the event the operator becomes financially unable or unwilling to undertake or complete implementation of approved decommissioning plans, regulatory agencies would access funds provided as financial assurance and oversee the decommissioning and reclamation work.

The following key information and assumptions were used to estimate the cost of decommissioning the McClean Lake Operation:

- An independent contractor carries out the work.

- The value of salvageable material and ore reserves are not credited toward the cost of decommissioning.
- Contingency allowances correspond to a Grade B estimate as defined by REGDOC 3.3.1 (CNSC 2021).
- Orano's experience with the following activities provide a good basis for cost estimation:
 - Demolition and decommissioning – Cluff Lake Project mine and mill
 - Excavation and earthmoving – McClean Lake Operation JEB TMF Optimization and Expansion Projects
 - Industrial construction projects – McClean Lake Operation McClean Lake Mill Upgrade Project
 - Progressive reclamation projects – JEB TMF Infrastructure Decommissioning Project
 - Revegetation – clean waste rock pile hydroseeding at the McClean Lake Operation, Cluff Lake Revegetation Program
 - Project management and administration – JEB TMF Optimization and Expansion Projects, McClean Lake Mill Upgrade Projects; decommissioning of the Cluff Lake Project
 - Environmental monitoring – McClean Lake Operation Environmental Monitoring Program, Cluff Lake Project Post-closure Monitoring Program
- Total cost estimate is discounted over the decommissioning period to year zero.
- Escalation rates are applied to cost estimates to compensate for inflation over the 5-year planning period. An annual inflation rate of 2.0% is applied based on Statistics Canada consumer price index for Saskatchewan in 2024 (Statistics Canada, 2024) and long term outlook.
- A two-year post-operational care and maintenance period has been included in the cost estimate to allow for preparation of detailed plans and completion of approval processes.
- Wage rates for contractors are based on current site construction project contracts and wage rates for operations personnel are based on the current collective bargaining agreement.
- Equipment rental rates are based on Saskatchewan Heavy Construction Association 2024 published rates and actual site project contract rates.
- Costs for water treatment are based on current unit rates for each of the JEB and Sue water treatment plants.

The financial cost estimate incorporates contingency allowances that are representative of a Grade B estimate. Orano draws on experience operating the Cluff Lake Project in northern Saskatchewan through the safe shutdown of operations, development, and approval of the Environmental Assessment (EA) and decommissioning license, and the successful decommissioning of mining and milling infrastructure. Implementation of a long-term environmental monitoring program has proven the site meets defined success criteria (Orano 2019a).

This decommissioning experience provides insight into the level of detail necessary for the McClean Lake Operation PDP to ensure, for the 5-year planning period, that the operation could be decommissioned with the allocated funds. Successive iterations of the PDP incorporate knowledge gained from progressive reclamation activities conducted onsite and the proposed costs for decommissioning are evaluated against the costs of current onsite projects to confirm the accuracy of estimated equipment rates, water treatment rates, personnel requirements, and administrative costs.

Cost estimates for decommissioning various components of the McClean Lake Operation are provided in the financial worksheets in Appendix B. Also provided are the estimated costs for the post-operational transition period following cessation of operations, which are discussed further in Section 5.1. Financial worksheets for general overhead costs during the post-operational period, active decommissioning and monitoring periods are provided. These estimates include costs for project management, environmental monitoring and reporting, inspections, camp, transportation, security, regulatory, and administrative fees.

Section 6 summarizes the proposed level of financial assurance resulting from the current estimate of decommissioning costs.

4 Decommissioning Strategy

4.1 Decommissioning Objectives and Success Criteria

The PDP includes detail sufficient to ensure that the proposed activities are, considering existing knowledge, technically feasible and appropriate to meet the decommissioning objectives. A detailed discussion on each of the nine (9) planning envelopes can be found in Section 5 of this plan.

While the closure principles in Section 2.4 are general in nature, decommissioning objectives are site specific. Objectives describe the post-closure land use in site specific detail whereas success criteria are the specifications, measurements or requirements that, if met, denote the success of the closure works in meeting the objective.

- **Water quality** is safe for anticipated human and wildlife consumption.
 - Water quality criteria are defined in relation to existing federal and provincial regulations or guidelines, considering site specific conditions. For identified contaminants of potential concern, where federal or provincial guidelines are not available, information obtained from scientific literature and site-specific conditions will be evaluated to derive benchmarks for inclusion as decommissioning criteria. Where guidelines may not be appropriate for specific aspects, such as water quality in open pits, a site-specific risk assessment will be conducted during the decommissioning licensing period to determine the requirements for the protection of wildlife and public safety.
 - **Success Criteria for Surface Water Quality** – surface water quality will be evaluated at natural lakes, rivers, and streams relative to Saskatchewan Environmental Quality Guidelines (SEQG) for the Protection of Aquatic Life. SEQGs will be met for specific parameters at designated locations unless site specific or regional water quality objectives are established through risk assessment (see Section 2.5.6) and accepted by SMOE and the CNSC.
 - **Success Criteria for Pit Lake Water Quality** – surface water criteria for pit lakes will be defined on a site-specific basis through risk assessment and regulatory approval.
- **Radiological Clearance:** The final radiological end-state will not pose unacceptable risk to traditional land users.
 - **Success Criteria:** measured through predicted annual effective doses that do not exceed the public dose limit (1 mSv per year above natural background). The end-state radiological levels will be as low as reasonably achievable (ALARA) and will be protective of social and economic factors.

The surface water quality and radiological objectives will be guided by the overarching criteria of:

- **Absence of Unreasonable Risk:** There is an absence of unreasonable risk when considering ecological connectedness including the connectedness among sediment, benthic invertebrate, and fish quality; soil and vegetation quality; wildlife; and consumption of country foods.
 - **Success Criteria:** the ecological and human health risk associated with the McClean Lake decommissioned site, as determined with probabilistic numerical modelling using land use assumptions from land users, must conclude an absence of unreasonable risk.
- **Geotechnical Stability:** Engineered earth structures (e.g. JEB TMF, waste rock stockpiles) are safe, stable, and performing as intended over the long-term with little to no ongoing maintenance.
 - **Success Criteria:** verified continued stability through third-party geotechnical inspections and analyses during various decommissioning phases based on long-term stability assessments conducted prior to decommissioning commencing and during interim monitoring.
- **Infrastructure** and created landforms (e.g., waste rock piles and mined out pits) on site will not pose a public safety hazard post-closure.
 - **Success Criteria** - the decommissioned site resembles other remote wilderness areas, e.g., comparable terrain and travel risks (slope, drop offs, egress).
- **Self-Sustaining Landscape:** Reclamation of the site such that the area is capable to re-establish quickly, without intervention, following disturbance.
 - **Success Criteria:** Establishment of vegetation communities compatible with the surrounding natural ecosystems.

4.2 Knowledge Base

Knowledge gaps and uncertainties are identified over the mining life cycle. A gap analysis is undertaken at regular intervals with knowledge base needs identified and accompanying studies, research and trials documented in the Environmental Monitoring Program Design Document. Although some studies, e.g., TOVP, are compliance related, most studies related to decommissioning are considered 'supplemental studies' in the Environmental Monitoring Program Design Document (Orano 2023a). Supplemental studies are documented and tracked but do not form part of the formal Environmental Monitoring Program.

This section summarizes current or upcoming studies. Completed studies, e.g., chemistry studies to support food-chain connections in ecological risk assessment, are documented in the Environmental Monitoring Program Design Document.

4.2.1 Receptor Water Bodies

Environmental monitoring of the Sink Vulture Treated Effluent Management System and downstream receptor water bodies (e.g. McClean Lake and Collins Creek) are performed under the guidance of the Environmental Monitoring Program (Orano 2023b). The results of environmental monitoring are consolidated and risk assessment results are presented every five years in the Environmental Protection Technical Information Document (TID, V1 and V2). Understanding the properties of sediment attenuation in the receiving environment downstream from the McClean Lake operation is an important facet of decommissioning. Follow-up studies will be required to verify the following key environmental factors:

- Detailed Decommissioning Plan for the management of S/V TEMS control structure removal, water release and habitat rehabilitation
- Understanding of current sediment loading and predictions of future loadings to downstream receptors
- Sediment loading capacity for key COPCs in key receptors
- Long-term sediment/wetland stability
- Potential contaminant transport from attenuation of COPCs
- Post-Decommissioning verification of surface water quality

As mentioned in Section 4.1, surface water guide guidelines are considered success criteria for ensuring water quality is safe for anticipated human and wildlife use. Where guidelines may not be appropriate, site-specific assessments will be conducted during the decommissioning licensing period to determine the requirements for the protection of wildlife and public safety. These costs are included in Table B2.19 of Appendix B.

4.2.2 Land Use and Diet

Over the next five-year period, Orano will continue to support the community research initiatives by the Athabasca Joint Environment Sub-committee (AJES) under the Ya'thi Néné to conduct diet studies in the Athabasca Basin communities. This work will directly inform and influence the ecological and human health risk assessment for the site (i.e., Environmental Performance TID) and validate that decommissioning plans will achieve an end state safe for continued land use as defined by regional residents and land users. These costs are included in Table B2.19 of Appendix B.

4.2.3 Tailings Optimization and Validation Program

In order to effectively predict, design for, monitor, and validate the ability of the decommissioned TMF to achieve the decommissioning criteria, a Tailings Optimization and Validation (TOVP) field-based program to sample the tailings is undertaken once every five years. One of the outcomes of the TOVP is measurement and prediction of COPC concentrations in tailings pore water. The tailings pore water source term is a key input to groundwater

contaminant transport modeling that is subsequently considered in the ecological and human health risk assessment (see Section 2.5.6). Other important model inputs include final tailings volume, elevation, consolidation, and engineered cover design (see Section 5.3.3).

The TOVP is a regulatory requirement to sample and evaluate the placed tailings. The tailings have engineered geochemical and geotechnical parameters which are designed to control post decommissioning release of contaminants from the tailings to the environment to acceptable levels which cause no significant effects. The TOVP results to date are reported in Section 5.8 of the McClean Lake Operation Tailings Management TID

To date, the TOVP program has confirmed the ability of the McClean Lake mill tailings preparation process to produce tailings with predictable and geochemically controlled source terms for a variety of ore sources with varying geochemical characteristics. Geotechnical studies have confirmed that the tailings are predicted to reach sufficiently low hydraulic conductivity values to cause groundwater to primarily flow around the tailings in the host sandstone (Orano 2025e). As such, the consolidated tailings are predicted to be suitable for the long-term control of COPCs entering the environment after decommissioning the JEB TMF. A final TOVP sampling program and report is included in the cost estimate in Table B2.20 of Appendix B.

4.2.4 Groundwater Modeling

A regional groundwater model has been developed as part of the initial assessment of the McClean Lake Operation. This model has been refined and calibrated to monitoring data collected routinely in accordance with the EMP. The most recent calibrated numerical groundwater flow model is documented in Section 5.5 of the McClean Lake Operation Hydrogeology and Groundwater Modelling of the Collins Creek Basin TID (AREVA 2011b). Costs for post-operational monitoring, interim monitoring and post-closure monitoring are outlined in Table B1.8, Table B2.19 and Table B2.20 of Appendix B, respectively. Non-Tailings Wastes: Detailed Disposal Plan

The Waste Rock Technical Information Document (WR TID) is updated at five-year intervals to support the understanding of potential environmental impacts from waste rock and other waste products at site during operations and after decommissioning (Orano 2023d) To support future decommissioning this document will be updated with disposal plans for waste materials at site to be included in contaminant transport modelling. Onsite project management costs during active decommissioning and interim monitoring periods are estimated in Appendix B, Table B2.18. The costs associated with environmental monitoring and reporting during the interim monitoring period and the post closure monitoring period are included in the Interim and Post-Closure Monitoring estimates (Appendix B, Tables B2.19 and B2.20). The costs for developing a detailed waste disposal plan are incorporated into these tables.

4.2.5 Pit Lakes

The Sue site is located within the McClean Lake Operation surface lease area. It includes the mined-out and flooded Sue C/A, Sue B and Sue E pits.

Contaminant transport modelling results presented in Section 6 of Part B of the 2023 WR TID indicate that the current approved decommissioning plan for McClean Lake Operation waste rock management in the Sue pits is protective of the water quality in Collins Creek and adjacent surface water bodies.

There is currently insufficient information at this time to effectively predict the water quality in the Sue pits post-decommissioning with respect to the concentrations of key COPCs, particularly, nickel and arsenic for the approved waste management scenario and the six other waste management scenarios presented in Section 3 of Part B of the WR TID.

In 2021, Orano initiated a program aimed at in-situ remediation of the Sue pits to ensure improved surface water quality at the time of decommissioning of the McClean Lake Operation. The program is being undertaken as a medium to long-term research initiative which will involve several stages of investigation, development, and implementation of the technique.

Orano plans to conduct in-situ remediation test work at the Sue E pit and an application for approval to conduct the test was submitted in August 2024. The test work includes reagent application (ferric sulphate and slaked lime) to Sue E pit water and a subsequent monitoring program. The objective of the test work is to reduce concentrations of nickel and arsenic in Sue E water. The results of the test work will be used to develop a long-term remediation program for Sue pits C/A, B, and E. The in-situ test has been designed based on the results of a bench scale test conducted earlier and ongoing pilot (tank) test. The Sue E pit test was initiated in June 2025.

As mentioned in Section 4.1, surface water guide guidelines are considered success criteria for ensuring water quality is safe for anticipated human and wildlife use. Where guidelines may not be appropriate, site-specific assessments will be conducted during the decommissioning licensing period to determine the requirements for the protection of wildlife and public safety. These costs are included in Table B2.19 of Appendix B.

4.2.6 Sink Reservoir

An iron-oxide stained area exists near a wetland area between the JEB WTP treated effluent discharge point and Sink Reservoir. The attenuation properties of the wetland area have begun to be assessed to have a complete understanding of the local attenuation of COPCs. Prior to decommissioning, studies will be conducted to determine the best path forward to fully leverage the absorptive capacity of the wetland and minimize disturbance to any attenuated COPCs. The cost estimate for remediation of this area is included in Table B2.8 of Appendix B.

The plan to decommission the Sink Reservoir dam is to breach the structure at three locations, one near each shoreline and the third in the location of the weir control structure. Studies and risk assessments will be completed prior to the work happening to ensure decommissioning of the dam is conducted in a safe manner. The cost estimate for these studies is included in the Geotechnical Inspections in Table B1.8 of Appendix B.

4.3 Long-Term Institutional Control

In 2007, the Province of Saskatchewan enacted the *Reclaimed Industrial Sites Act* and the Reclaimed Industrial Sites Regulations to establish an Institutional Control Program (ICP). The legislation allows for the transfer of a decommissioned site, or portions of the site, back to the Province and details the funds, provided by the owner/operator, required to maintain a long-term monitoring and maintenance program.

It is Orano's intention to transfer the McClean Lake property (including the Midwest site) into the Provincial ICP.

Achievement of the decommissioning objectives will result in an end-state which is protective of the environment and the public with perpetual, passive care; active controls are not expected to be required post-closure. Landforms and waste management areas will be safe, stable and self-sustaining. Parcels of the McClean Lake Operation surface lease are expected to successfully enter the Province of Saskatchewan's institutional control framework requiring administrative controls placed on future land use to prevent re-development of waste management areas. The site is intended to have unrestricted access for traditional land uses.

4.4 Progressive Decommissioning

Orano's strategy is to capitalize on decommissioning works and reclamation activities during the operational life of the mine site when there is a favorable return on investment and/or when the works can lead to a state with increasingly passive care. A progressive decommissioning program during the operational phase allows for a portion of work described in the PDP to be completed prior to cessation of operations. This approach offers several advantages, including the opportunity to identify technically challenging issues in advance so that adaptive or mitigative measures can be implemented.

Section 7 provides a summary of progressive decommissioning works completed to date and details parcels of progressive decommissioning that are intended to achieve final closure success criteria. For these parcels to be deemed decommissioned, and potentially re-classified as 'undeveloped' under the Provincial surface lease, regulatory approval must be obtained with mutually agreed success criteria and, if required, monitoring. Associated designs, as-builts, and reports will be detailed for eventual inclusion in a closed mine registry under the provincial institutional control program.

4.5 Uncertainty and Contingency

Mine voids and mine waste deposits are generally permanent modifications of the land, and their closure requires design horizons that extend for many hundreds of years. Climate is an important input to closure design, and significant changes in global climate are predicted based on current climate models made. Closure planning should consider the impacts of a changing climate on closure design:

- Design storm changes – max probable flood for surface water control structures
- Water balance changes – cover infiltration performance

- Stream volumes – reduced assimilative capacity

The financial cost estimate incorporates contingency allowances that are representative of a Grade B estimate.

4.6 Operational Management during Decommissioning

4.6.1 Quality Management

The McClean Lake Operation has developed an Integrated Management System (IMS) which provides an overall structure for all aspects of product quality, processes, and support services (Orano 2025c). The McClean Lake Operation received ISO 14001 certification in 2000. The ISO 14001 certification ensures that Environmental Management Systems used by Orano conform to rigorous international standards and continually strive to improve environmental protection.

The IMS, including revised procedures and work instructions, will continue to apply during phases of decommissioning and reclamation. Because the IMS is dynamic, changes and/or additions required specifically for decommissioning will be integrated as necessary to ensure appropriate quality control over critical activities.

4.6.2 Environmental Protection Program

The procedures and work instructions established under the IMS for the Environmental Management Program are mostly expected to apply to the decommissioning stage of the McClean Lake Operation. Procedures and work instructions will be reviewed and adjusted to ensure environmental protection during decommissioning activities. Effectiveness of the environmental protection measures will be assessed via environmental monitoring.

The core activity of the monitoring program is to acquire the data essential for assessing impacts of the operation and for ensuring that possible impacts are detected as early as possible and mitigated where necessary. The decommissioning and post-decommissioning environmental monitoring program (EMP) will be based on the McClean Lake Operation Environmental Monitoring Design Document and the McClean Lake Operation EMP Locations, Frequencies and Parameters (Orano 2023a and 2023b, respectively), which is developed and reviewed in line with standards of CSA N288.4, 288.5, and CSA N288.7. Specific monitoring locations, parameters and frequencies to be used during active decommissioning and post-closure periods will be based on compliance and tracking the achievement of decommissioning environmental performance and regulatory approval. Monitoring of effluent and emissions will continue for as long as those releases persist. It is expected that the extent of the decommissioning EMP will generally reflect the state of completion of site decommissioning, with reduced monitoring frequency as decommissioning is completed and the rate of environmental changes on site diminishes.

Mining activities can have impacts (both negative and positive) on biodiversity throughout the mine life. Key principles for protecting and promoting biodiversity at all stages of the mining life cycle are outlined in the Orano's Mining Biodiversity Strategy. Biodiversity is also considered within the sustainable development framework of the McClean Lake Operation. This framework represents an integrated approach to environmental protection

encompassing three main processes: environmental assessment, adaptive management, and continual improvement. The potential impacts of the McClean Lake Operation on the environment were considered through the environmental assessment process and mitigated during construction and operation to protect biodiversity in the McClean Lake Operation area.

Orano manages biodiversity at the ecosystem level through the minimization of habitat disturbance and regular reviews of the environmental risk assessment for valued ecosystem components, which support ecosystem structure and function as well as significant cultural, social, and economic values (AREVA 2017). If unacceptable risks are identified, a mitigation plan is developed to reduce levels of potential impact. The same approach is to be implemented during the decommissioning. Potential impacts from the decommissioning activities on biodiversity will be avoided and minimized early on through proper planning, execution of the environmental management program, and implementation of the mitigation measures. Achievement of decommissioning objectives will result in significant reduction of the anthropogenic footprint and provide healthy habitat for local species.

4.6.3 Radiation Protection

The procedures and work instructions established under the IMS for the Radiation Protection Program are expected to apply during active decommissioning at the McClean Lake Operation. These procedures and work instructions have been established to control worker radiation exposure doses using standardized methods and will be updated as required for decommissioning activities. Dosimetry monitoring of personnel will continue to follow established, conservative, risk-informed processes.

The requirement to keep radiation exposures ALARA, social and economic factors taken into account, will be respected as an overall guiding principal. A revised Code of Practice for Radiation Protection will be prepared to complement the DDP. It will detail appropriate administrative and action levels for control of radiation exposure.

For equipment and other items considered salvageable during decommissioning, contamination control measures will remain in place to minimize the spread of radioactive materials into unintended locations. Methods used to identify and quantify radiological contamination, to determine the acceptability of the contamination relative to defined limits, and to record and communicate results, are currently detailed within the IMS.

4.6.4 Health and Safety

Conventional health and safety activities during decommissioning will be conducted in a manner similar to operational activities, with adaptations as required. As with the operational phase of the McClean Lake Operation, protection of the health and safety of workers, contractors, and the public will remain paramount throughout all phases of decommissioning.

The procedures and work instructions established under the IMS and part of the Occupational Health and Safety Program, as well as The Occupational Health and Safety Regulations, 2020, will apply during phases of decommissioning and reclamation. A cornerstone of the Occupational Health and Safety Program is the identification of hazards and mitigation of risks through the implementation of processes for these activities.

Formal processes for hazard identification and risk assessment will continue throughout the decommissioning phase.

4.6.5 Training

The procedures and work instructions established under the IMS for training will apply during phases of decommissioning and reclamation with revisions as appropriate and approved. Several tasks and circumstances associated with the decommissioning phase will be unique to that phase. It is therefore recognized that training requirements will require updating at that time for specific decommissioning activities.

4.6.6 Emergency Response

The Emergency Response Plan, including but not limited to Environmental Emergency Response, Environmental Monitoring Field Safety Procedures, Water Quality Contingency Plan (potable water), and Emergency Response Assistance Plan, will continue to apply during decommissioning and reclamation phases. The Emergency Response Assistance Plan (Orano 2024) provides guidance to senior management and direction to emergency response personnel for off-site transportation incidents.

4.6.7 Site Security

Appropriate measures required to control site access, to prevent unauthorized removal of materials, and to ensure the identity of all persons on-site will be maintained in a manner similar to that of the current operating period. The procedures and associated work instructions established under the IMS for site security will continue to apply during phases of active decommissioning.

4.6.8 Operational Record Keeping

Operational records will be maintained during operations for the purpose of updating future decommissioning plans and to assist in the preparation of the final DDP prior to actual decommissioning activities. Operational records will include the following information:

- McClean Lake Operation Facility Description Manual;
- Records of spills and cleanups;
- Inventories of reagents and chemicals;
- Locations of waste disposal grounds and inventories of waste materials;
- Locations and inventories of reusable material storage areas;
- Radiation survey data;
- Locations of re-vegetation areas and the relative success of various re-vegetation efforts;

- Results of investigations and studies such as the Tailings Optimization and Validation Program and TIDs; and,
- Environmental monitoring data collected as part of the EMP.

All spills and incidents are tracked internally and will continue to be documented throughout operations to support updates to future decommissioning plans and preparation of the DDP. Any reportable spills, including associated follow-up and remediation activities, are reported to regulatory agencies after each incident in accordance with the existing approvals and licences, and summarized in the annual report. Although a detailed list of spills and associated remediation costs are not included in this version of the PDP, the remediation costs are not expected to materially affect the overall cost estimate. The PDP cost estimate incorporates contingency allowances that are representative of a Grade B estimate which includes an elevated contingency intended to address uncertainty and unforeseen items, including any unanticipated remediation requirements. A list of spills and associated remediation costs will be included in the next 5-year update to the PDP.

5 Preliminary Decommissioning Work Plan

The following sections provide preliminary details of the anticipated decommissioning activities upon closure of the McClean Lake Operation. Section 5.1 and 5.2 provide pre-decommissioning costs during the shutdown process of the facility and Detailed Decommissioning Planning. Sections 5.3 provides an overview of activities and costs for the various physical facilities to be decommissioned, grouped by planning envelope, which can proceed upon completion of the DDP. Section 5.4 provides information on the post-decommissioning monitoring and transition of the site to institutional control.

The following sub-sections provide a short synopsis of methodologies that will be used when decommissioning the major facilities within each planning envelope. The planning envelopes at the McClean Lake Operation are outlined on Figure 3 through Figure 9. Financial estimate development tables for the post-operational period are included in Appendix B, Tables B1.1 to B1.9 and for the nine decommissioning planning envelopes in Appendix B, Tables B2.1 through B2.11. Also provided are equipment rental rates, unit rates, and inventory of materials onsite that were used to develop an estimate of the decommissioning cost for each planning envelope (Appendix B, Tables B2.12, B2.13, and B2.15). A summary of changes to unit rate costs compared to previous versions of the PDP is provided in Appendix B, Table B2.14.

Preliminary decommissioning planning will follow an adaptive management strategy, meaning that decommissioning plans will evolve over time. The following sub-sections represent closure activities with high success probability. Decommissioning plans will be refined through stakeholder engagement, lessons learned from progressive decommissioning, research, and changes in best management practices. For example, where active water treatment is proposed in this plan, future decommissioning plans may demonstrate that passive treatment options will be effective, or source controls eliminate the need for treatment.

A general objective for all decommissioning planning envelopes is that all areas to be decommissioned will undergo a radiological scan to ensure that the general landscape meets the radiological decommissioning

objectives that will be established in the Detailed Decommissioning Plan (DDP). Material will be segregated and recycled as much as practical.

5.1 Post-Operational Conditions

A conservative approach has been applied to this PDP; it is assumed that site operations will undergo sudden, unexpected closure. However, under normal circumstances, notice would be given to regulators prior to ceasing operations. The post-operational phase represents the period immediately after production has ceased and it is necessary to place the McClean Lake Operation into a safe and secure state in preparation for decommissioning. Although development of the DDP and securement of licenses and permits are anticipated to occur during the operational period, it is assumed that a DDP would not have been completed in a sudden, unforeseen closure scenario and will extend into the post-operational period.

During the immediate post-operational phase, detailed plans would be developed for the specific physical works to be conducted to bring the site to a secure state of closure prior to extensive decommissioning works. Detailed planning, licensing, and permitting may also commence. For a planned closure scenario, the development of a DDP and securement of licenses and permits would be conducted by the operator concurrent with final operations of the site.

5.1.1 Shut-down Process

The following activities would occur as part of the McClean Lake Mill shut-down process (including ancillary facilities), prior to demolition work, to mitigate potential safety and environmental hazards and prepare the site for decommissioning:

- The McClean Lake Mill will undergo a progressive reduction in productivity to exhaust the onsite inventory of ore and reagents during the shutdown process.
- Determine a detailed waste disposal plan to ensure that all wastes are geochemically compatible with their final disposal location and contaminant transport modelling identifies no significant environmental effects to the receiving environment.
 - Potential disposal options include:
 - The JEB TMF for materials treated through the tailings neutralization circuit which are oxidizing and achieve appropriate geochemical parameters
 - The Sue C/A Pit and contaminated landfill for materials compatible with pit water quality remediation and contaminant transport modelling
 - Industrial Landfill for materials with no radiological contamination which will not generate source terms of COPCs

- Transport off site for salvageable materials or those which meet the criteria of specialty disposal companies
- The following materials will be disposed of in accordance with the detailed disposal plan:
 - McClean Lake Mill circuits will be cleaned of residual ore materials and chemicals
 - Mill reagents, nuclear gauges, and hazardous wastes
 - Stockpiled waste (i.e., sludges or special waste rock)
 - Materials that pose a hazard during the post-operational period prior to active decommissioning
- Remaining ore will be disposed of in the Sue C/A pit and capped as required to prevent the release of contaminants. Alternatively, it may be placed in the Sue C Contaminated Landfill depending on volume and available space.
- Electrical circuitry that is not required in the decommissioning process will be physically disconnected.
- Ventilation equipment and the dust collection systems will be cleaned and disconnected.
- Piping will be flushed with water, blown out, and disconnected at suitable locations.
- Propane lines will be purged with an inert gas and disconnected.
- Remaining contaminated areas in the mill will be washed down with clean water and those waters directed to contaminated sumps and then treated prior to release to the environment.
- Equipment will be drained of oils and coolants, and these will be disposed of as per hazardous materials requirements.
- Fireguards will be employed when there is a risk of inadvertent combustion (e.g., fuel tank reduction).
- Work zones will be delineated and barricaded to prevent unauthorized access.
- Buildings not in use will be locked out to prevent unauthorized entry.
- Open excavations will be identified, and access will be barricaded.
- Materials removed from site will be cleared through radiometric scanning for unrestricted use off-site, as per current practice.

Certain facilities, such as the water treatment plants, will be required throughout the decommissioning phase. Regardless of timing, shutdown of remaining facilities will follow the processes noted above.

Mill reagents, propane, and diesel fuel represent the majority of bulk hazardous materials at the McClean Lake Operation. It is assumed that fuels and propane will be consumed during the post-operational and decommissioning activities. Despite efforts to reduce mill reagent inventory during the shut-down process, there will remain residual chemical and hazardous wastes to be managed. The options for managing these residual wastes include:

- Return, transfer, or sale of unused reagents to suppliers or other operating mines;
- Disposal of residual wastes onsite in either the JEB TMF, Sue C Contaminated Landfill or Sue C/A pit, as appropriate; and
- Transport of waste materials offsite for disposal or recycling in accordance with applicable regulations.

Inventory of the estimated hazardous waste remaining after shutdown of the McClean Lake Mill are noted in Appendix B, Table B1.3. The cost associated with transporting these materials offsite are based on current contracted rates for the McClean Lake Operation and does not account for salvage value from the sale of unused bulk reagents. A 25% contingency amount is applied to account for variability in onsite inventory.

Upon completion of shut-down processes, the facilities will be ready for demolition. As contaminated materials will be consolidated into either the JEB TMF, Sue C Contaminated Landfill, or the Sue C/A pit, efforts to decontaminate facilities beyond those described above will not be undertaken unless identified through risk assessment that it is required for the protection of worker health and safety during the decommissioning work. Generally, the JEB TMF can accept oxidized, pH neutral, or inert materials that are geochemically compatible with the tailings. The Sue C/A pit/ Sue C contaminated landfill, which is a more assessable disposal location contained within the Sue C/A pit, can generally accept reducing materials, such as ore, special waste rock, and certain process sludges where the potential source terms of which have been evaluated for effects on the downstream environment.

At the end of operations, areas will have contamination levels corresponding to their established radiological contamination control zone criteria. Materials and equipment used in the processing of uranium ores will be considered contaminated unless demonstrated to be clean through the radiological clearance process.

5.1.2 Detailed Decommissioning Planning

Detailed Decommissioning Planning is expected to take place during the final years of operations so that regulatory approved decommissioning works can be initiated without delay (see Section 2.5.3). However, for the purposes of a conservative PDP, it is assumed that operations undergo sudden, unexpected closure with the following activities conducted during a 2-year period following the cessation of operations, before major physical decommissioning and reclamation occurs:

- detailed plans for the physical work of decommissioning would be developed, tendered and contracted;
- hazard identification and risk assessment will be carried out on Detailed Decommissioning Plans to ensure worker health and safety, and environmental protection; and,
- continued water treatment operations at the JEB and Sue WTPs will be conducted during the period to treat contaminated water and to maintain water levels as necessary at the JEB TMF and the Sue C/A pit.

As outlined in Section 4.6, during the detailed planning stage, revisions to operational plans and the IMS will occur, to ensure they are appropriate for decommissioning and are acceptable to the regulatory authorities.

Cost estimates for the work to be completed during the post-operational period are provided in Tables B1.1 through B1.9 of Appendix B and include estimates for:

- water treatment at the JEB and Sue water treatment plants;
- cleanup of hazardous waste materials on storage pads and residual reagents from mill circuits, and removal of nuclear gauges;
- project management inclusive of personnel and administrative costs incurred to operate the site remotely;
- operating costs that include applicable utilities and communications costs;
- costs associated with ensuring the security of the site;
- transportation of site personnel;
- conducting the environmental and radiation monitoring programs; and,
- associated fees for regulatory oversight and regulatory process fees for decommissioning licensing.

For current operations at McClean Lake, the administrative costs associated with room and board, catering and janitorial services for personnel onsite, as well as the cost of providing onsite transportation, office space, telephone and internet communications, and a provision for recreational activities are accounted for by the application of a daily overhead rate of \$80 per person (Appendix B, Table B1.5). A similar rate is used for budgeting of Orano's current projects. This rate has been applied to estimate the cost of operating a camp at the McClean Lake Operation or housing personnel at the nearby Points North Landing camp facility during the post-operational period.

If an unexpected closure occurred, ownership and administration of the site would be transferred to the Province of Saskatchewan and, as such, property taxes and surface lease fees would no longer apply. Also, property

insurance would no longer be purchased for assets planned for demolition. During the post-operational cleanup period, activities are assumed to be carried out by contracted companies that are required to carry insurance and be registered and in good standing with the Workers' Compensation Board (WCB). Estimated CNSC license fees during the post-operational period are included in Table B1.9 of Appendix B.

The total estimated cost for the post-operational period amounts to approximately \$12,155,180 (see Section 6).

5.2 Administrative and Project Management Costs during Decommissioning

The administrative costs associated with room and board, catering and janitorial services, onsite transportation, office space, telephone and internet communications, and recreational activities are accounted for by the application of a daily overhead rate of \$80 per person (Appendix B, Table B2.17). For the post-closure monitoring period, these administrative items are captured in the estimated cost to conduct campaign environmental monitoring (Appendix B, Table B2.20).

Onsite project management costs during active decommissioning and interim monitoring periods are estimated in Appendix B, Table B2.18. The costs associated with environmental monitoring and reporting during the interim monitoring period, when active decommissioning and water treatment activities are occurring, and the post-closure monitoring period are included in the Interim and Post-Closure Monitoring estimates (Appendix B, Tables B2.19 and B2.20). The anticipated fees associated with regulatory oversight during these periods are also included. Annual license fees for the decommissioning and post-closure periods are included in the line item identified as CNSC Fees in Tables B2.18, B2.19, and B2.20 of Appendix B. As noted in the previous section, it is not expected that property taxes or lease fees will apply during the decommissioning and post-closure monitoring periods as the site will be managed by the Province of Saskatchewan.

5.3 Decommissioning Activities by Planning Envelope

Table 5.3.1 outlines the waste rock inventory (as of December 2025) and management locations of waste rock from each completed project. Information regarding the waste rock inventory is included in Table 7.2-1 of Section 7.2.1 of the McClean Lake Operation Environmental Performance Technical Information Document (EP TID) Volume 1 (Orano, 2025a).

The planning envelopes for the decommissioning activities outlined in the following sections are expected to require less than 600,000 m³ of overburden. The volumes presented in Table 5.3.1 show there will be sufficient volumes of waste rock to support anticipated decommissioning activities. Clean waste rock is also suitable for future decommissioning activities and may be used if needed.

Table 5.3.1 Current Waste Rock Inventory (December 2025)

Pit	Material Type	Location	Volume (bcm)	Mass (tonnes)
JEB	Organic Overburden	JEB Organics Stockpile	128,369	82,541
	Till Overburden and Clean Waste Rock	JEB Clean Waste Rock Stockpile	4,372,673	10,625,595
Sue C	Overburden	Sue C Overburden Stockpile	857,328	1,886,122
	Overburden and Clean Waste Rock	Sue C Clean Waste Rock Stockpile	9,961,302	24,205,964
Sue A	Overburden	Sue C Pit	124,580	274,076
Sue B	Overburden	Sue C Overburden Stockpile	184,634	406,195
Sue E	Overburden	Sue E Overburden Stockpile	462,967	1,018,527
	Clean Waste Rock	Sue E Clean Waste Rock Stockpile	4,572,907	11,018,527

5.3.1 Planning Envelope # 1: JEB Mining Area

5.3.1.1 Description

The JEB Mining Area planning envelope (Figure 3) consists of facilities at the JEB site that are not associated with the JEB TMF, the McClean Lake Mill area, or the Permanent Camp planning envelopes that follow. The decommissioning financial summary for Planning Envelope #1 – JEB Mining Area is provided in Table B2.2 of Appendix B.

The JEB Mining Area includes:

- JEB Clean Waste Rock Stockpile – Clean waste rock removed during the mining of JEB pit.
- JEB Overburden Stockpile – Clean till overburden material excavated during the JEB TMF Optimization and Expansion projects since 2012. Two stockpiles were created; one north and one south of the JEB TMF.
- JEB Industrial Landfill – Non-contaminated industrial solid waste located on the western side of the JEB Clean Waste Rock Stockpile. The industrial landfill was expanded in 2019. Industrial waste has been deposited in the Sue C/A Contaminated Landfill since 2023, as part of an initiative to centralized waste. The Industrial Landfill remains available for use as a contingency.

- Sewage Solids Management Area – Sewage bio-solids from all sources at the McClean Lake Operation, located on the top of the JEB clean waste rock stockpile.
- Hydrocarbon Landfill – Hydrocarbon-contaminated soils are stored in the hydrocarbon landfill until there is space on the hydrocarbon landfarm to transfer the soils for remediation.
- Hydrocarbon Landfarm – Soils transferred over from the Hydrocarbon Landfill. This soil is remediated in the landfarm that is located on top of the JEB clean waste rock stockpile (Figure 3).
- JEB Organic Stockpile – Prior to mining and as part of TMF expansion, organic material was removed from within the perimeter of the JEB pit and stockpiled.
- Clean Waste Rock Runoff Pond – The unlined waste rock runoff pond at JEB is used to collect runoff water from the surface of the clean waste rock stockpile.
- Special Waste Pad – The lined special waste pad was used to store special waste rock during the mining of JEB pit. The JEB special waste was deposited in Sue C and the pad has since been used to temporarily store miscellaneous radiologically contaminated material from operational activities.
- JEB Ore Pad – The ore pad is used to store ore prior to feeding into the McClean Lake Mill. A lined ditch around the ore pad collects surface runoff from the ore pad for treatment.
- JEB Ore Pad Pond – A lined pond was constructed in 2016 adjacent to the JEB ore pad to provide additional stormwater storage capacity for the ore pad runoff ditch via an overflow swale.
- Contaminated Materials Storage – A lined area used throughout the life of the mill to store equipment that is contaminated but may be re-used in the mill.
- Fire Training Area – This area on the JEB waste rock pile is used by the Emergency Response Team to train for firefighting.
- Associated Pipelines & Culverts – Discharge and water routing pipelines, mostly double contained HDPE pipe with heat tracing. Culverts exist in the ditches as either protective barrier for pipelines or for the routing of runoff water.
- Mining Sedimentation Ponds – Three former sedimentation ponds used during the mining of JEB pit, already decommissioned.
- Temporary Contaminated Material Landfill – The former temporary contaminated material landfill was used to store radiologically and chemically contaminated waste, which was located on the brow of the JEB TMF. The temporary contaminated material landfill was decommissioned, and all waste relocated to the Sue C pit for permanent disposal in 2017. No further decommissioning is required.

5.3.1.2 Preliminary Decommissioning Approach

JEB Clean Waste Rock Stockpile

The JEB clean waste rock stockpile will be used as the material source to backfill the JEB TMF and other areas that require large fills. The remaining waste rock pile will be contoured to slopes of 3H:1V, where possible. Approximately three of four sides of the current stockpile are currently re-contoured and partially re-vegetated. Recontouring and revegetation will be completed during decommissioning. JEB Clean waste rock is used as construction material for the JEB TMF embankment expansion.

JEB Overburden Stockpiles

The north and south overburden stockpiles will be used as clean till cover material for the JEB TMF and mill areas. Unused material will be re-contoured to blend in with the surrounding area and re-vegetated. Cleared stockpile pads will be scarified and re-vegetated. This material is used as construction material for the JEB TMF embankment expansion.

Industrial Landfill

The JEB industrial landfill was expanded in 2019 by 0.85 hectares. The only change to waste management strategies required was incorporation of a low spot for runoff accumulation that will be pumped out as necessary. The expanded landfill is expected to provide adequate capacity for the disposal of industrial waste for the remaining life of mine.

Orano received regulatory acceptance to dispose of industrial waste in the Sue C/A Contaminated Landfill. The Industrial Landfill will remain available for industrial waste as a contingency, until decommissioning planning progresses to where Orano is confident that the landfill is no longer required.

When usage of the industrial landfill is complete, the active trench in the JEB clean waste rock pile will be backfilled with clean waste rock. The contents of the landfill will be covered with a minimum of 2 m of clean waste rock material during the re-contouring operation, followed by re-vegetation.

Sewage Solids Management Area

The majority of sewage solids in the Sewage Solids Management Area at the time of decommissioning will be composted and utilized in reclamation of the JEB clean waste rock pile. The anticipated volume of these materials is expected to be a few cubic meters due to continuous breakdown during the sewage treatment process.

Hydrocarbon Landfill and Landfarm

The landfarm soils will be allowed to biodegrade and, once clearance criteria is met, the material will be used as a till cover for other areas. The hydrocarbon landfarm will remain operational during the decommissioning period to allow for remediation of impacted soils generated during decommissioning activities. Reclamation of the landfill and landfarm will be conducted as part of the re-contouring and re-vegetation of the JEB clean waste rock stockpile.

JEB Organic Stockpile

This material will be used throughout the life of the project and at decommissioning for re-vegetation of disturbed areas. It will contribute organic content, natural seed sources and water retention capability to the re-contoured areas. Since this stockpile will be used for decommissioning, the area of the stockpile will be scarified and re-vegetated, if necessary.

Clean Waste Rock Runoff Pond

Water remaining in the pond at the time of decommissioning will be treated, if necessary, and discharged to the S/V TEMS. Sediment in the pond will be sampled and analyzed. Sediment not meeting decommissioning objectives will be removed and disposed of in the JEB TMF or Sue C/A pit. The pond will be re-contoured to blend in with local topography.

JEB Ore & Special Waste Pads

Remaining ore that is economically feasible will be processed through the McClean Lake Mill. In the event unprocessed ore remains, it will be placed into the Sue C/A pit and covered as required. Alternatively, it may be placed in the Sue C Contaminated Landfill depending on the volume and available space. Miscellaneous contaminated material remaining on the JEB special waste pad will be placed into either the JEB TMF, the Sue C Contaminated Landfill or the Sue C/A pit, as deemed appropriate. The liners from both areas will be cut into manageable pieces along with overlying cover material and will be disposed of in the JEB TMF. The ground below the liners will be assessed to determine if remediation is required. Material deemed contaminated will be deposited in the JEB TMF, or Sue C/A pit if appropriate, and residual contamination will be covered with clean till to a depth sufficient to meet final radiological criteria. Excavations will be filled with clean waste rock, pads will be scarified, and a till cover will be placed over the area and re-vegetated.

JEB Probable Maximum Precipitation (PMP) Pond

The JEB PMP pond was constructed to provide additional stormwater storage capacity for the adjacent JEB ore pad. The pond was designed with a storage capacity of 30,850 m³ plus a 1 m allowance for freeboard and is lined with a single layer of bituminous geomembrane impermeable liner. The pond is sized to contain a PMP storm event and is connected to the ore pad collection ditch (D7 ditch) via a lined overflow swale. The pond is maintained in a dry state to maintain the intended PMP capacity.

Water remaining in the pond at the time of decommissioning will be treated and discharged to the S/V TEMS. Sediment in the pond will be processed through the mill or disposed of in the JEB TMF. The liner will be removed and disposed of in the JEB TMF, Sue C Contaminated Landfill or Sue C/A pit upon decommissioning. The pond berms will be re-contoured to blend in with local topography.

Contaminated Materials Storage

Materials stored in this area will be disposed of in the JEB TMF, Sue C Contaminated Landfill, or Sue C/A pit in a similar manner to demolition debris from the McClean Lake Mill. The liner will be cut and disposed of along

with contaminated materials found below the liner. The depression will be backfilled with clean waste rock and contoured to blend in with the JEB clean waste rock pile and re-vegetated.

Fire Training Area

The fire training area uses petroleum products to conduct necessary safety training for emergency response. As such, surficial soils may be impacted with residual hydrocarbons. Sampling of these soils will be conducted prior to decommissioning to assess the level of contamination. Impacted soils will be remediated at the hydrocarbon landfarm. Un-remediated impacted soils or materials will be disposed of in the Sue C Contaminated Landfill or Sue C/A pit. The end-state will be to contour the fire training area to blend in with the JEB clean waste rock pile and re-vegetate.

Associated Pipelines, Culverts & Roadways

Pipelines will be flushed with clean water and blown out to minimize the potential for spills before removal. All water will be captured and directed for treatment at the JEB WTP or contained and transported off site for treatment. Unused pipelines will be disconnected, cut into manageable lengths, and disposed of. Culverts will be removed and disposed of. Roads will be scarified, re-contoured (if necessary), and re-vegetated.

5.3.2 Planning Envelope # 2: McClean Lake Mill and Associated Facilities

5.3.2.1 Description

The McClean Lake Mill and Associated Facilities planning envelope (Figure 3) comprises the McClean Lake Mill terrace area and support infrastructure, excluding the JEB TMF, JEB mining area, and the permanent camp. The decommissioning financial summary for Planning Envelope #2 – McClean Lake Mill and Associated Facilities is provided in Table B2.3 of Appendix B. For further information on the McClean Lake mill process and components, refer to the McClean Lake Operation Facility Description Manual (Orano 2022).

The McClean Lake Mill and Associated Facilities planning envelope includes the following infrastructure:

- **McClean Lake Mill/Office Complex** – The mill complex contains various buildings housing the necessary components for the mill process as well as maintenance, warehousing, laboratory, and office areas. Numerous hazardous (i.e., reagents, chemicals, etc.) and radiological materials (i.e., ore, nuclear gauges, etc.) are stored and used in the processing of uranium ore to a yellowcake (U_3O_8) product. The McClean Lake Mill complex includes most of the facilities on the mill terrace that support the mill process and comprise the following:
 - Ore Receiving and Grinding;
 - Slurry Receiving;
 - Leaching Circuit;

- Solvent Extraction Circuits;
 - Clarification and Precipitation Circuits;
 - Sulphuric Acid Plant and Ammonium Sulphate Crystallization Plant;
 - Ferric Sulphate Plant;
 - Calcining and Packaging;
 - Oxygen Plant;
 - Tailings Thickening and Tailings Neutralization circuits;
 - Yellowcake and Reagent Storage;
 - Potable Water Treatment Plant; and,
 - Ancillary Areas (Mill Dry, Warehouse, Maintenance Area, and Offices).
- **Mill Site Runoff Pond** – Collects surface runoff water from the mill terrace and directs it to either the JEB TMF or to the JEB Water Treatment Plant (WTP).
 - **Temporary Sludge Ponds (2)** – Ponds were constructed to contain treated filtered sludge from JEB WTP sludge prior to the mill start-up and are currently used for surge capacity in the Ammonium Sulphate Crystallization (CX) plant.
 - **Clean Laydown Area** – Outdoor area used to store large equipment/materials that are not radiologically contaminated.
 - **Cold Storage Building** – An unheated building used to store new stock supplies for the JEB warehouse.
 - **Warehouse Storage Compound** – Outdoor laydown area containing racks and shelving for storing additional new stock warehouse items.
 - **Propane Bullets (4)** – Three of the propane bullets are used for heating the McClean Lake Mill facilities and one is used to heat the JEB mechanical shop and construction trailers.
 - **Hazardous Materials Storage Pad** – Used to temporarily store hazardous waste dangerous goods prior to shipment off-site for recycling or disposal. Two steel storage containers located on the pad provides covered storage for most products.
 - **Services Shop & Offices** – Contains equipment and material storage for general maintenance activities, as well as offices and a carpentry shop.

- **JEB Mechanical Shop** – Mechanical shop for maintenance and repairs of light and medium duty vehicles and general equipment. Contains storage for both new and used oils, glycols, and lubricants.
- **Equipment Storage** – Unheated, two-bay covered structure for storing large mobile equipment.
- **Construction Management Office** – Temporary office trailers used by construction project management.
- **Environment Storage Building** – Field storage for equipment and supplies used by the Environment Group.
- **Fuel Tanks (4)** – Two diesel fuel tanks and one gasoline fuel tank used for fueling light vehicles and heavy equipment. One diesel tank was formerly dedicated to providing fuel for the site backup generator which is no longer in use. This diesel tank has been emptied and removed from use.
- **Waste Oil Tanks (1)** – Located behind the JEB maintenance shop and stores used waste oils generated onsite. Waste oil is shipped offsite to a licensed disposal facility.
- **Calumet Tanks (2)** – Two tanks used to store calumet for the mill process.
- **Anhydrous Ammonia Tanks (3)** – Three tanks used to store anhydrous ammonia for use in the solvent extraction circuit and yellowcake precipitation circuit.
- **JEB Water Treatment Plant** – Treats contaminated process water as well as other wastewater from the JEB TMF, site runoff pond, and other sources prior to discharging treated effluent to the S/V TEMS.
- **Monitoring Ponds (3)** – The monitoring ponds receive treated effluent from the JEB WTP; they are used as the final water quality check point before discharge to the S/V TEMS.
- **Ancillary Buildings** – External buildings to the mill which include the training building, temporary contractor trailers, and the concrete batch plant structure. In addition, fabric covered buildings provide unheated storage of magnetite used in the mill process, temporary warehouse supplies, and temporary construction project storage.
- **Powerhouse** – Provides backup diesel power generation for the mill and camp facilities. Holds 6 small diesel fuel tanks.
- **Utilities & Pipelines** – Various infrastructure to serve the overall mill process.
- **McClellan Lake Mill Terrace & Roadways** – Compacted overburden pad that the McClellan Lake Mill is constructed on which serves as a barrier between mill contaminants and the underlying native soils as well as directing surface runoff water to the mill site runoff pond. Various roads link the mill site to the JEB mining area, camp, main site access (site security gatehouse), and the Sue mining area.

5.3.2.2 Preliminary Decommissioning Approach

McClellan Lake Mill Complex

As described in Section 5.1, during shutdown of the McClellan Lake Mill in the post-operational period, the majority of bulk reagents, ore, nuclear gauges, and hazardous wastes will be removed from the mill disposed of based on the criteria determined under the detailed disposal plan (Section 5.1.1)

During active decommissioning, the general concept for McClellan Lake Mill demolition will be to dismantle and salvage, to the extent possible, interior equipment, mechanical and electrical works, piping, tanks, and catwalks followed by demolition of the building structure. Non-salvageable materials will be reduced by cutting or crushing for disposal. The general demolition procedure is as follows:

- Exterior cladding of the buildings will be removed to provide natural light for visibility and safety and to provide air circulation thus minimizing radon progeny concerns and allowing more efficient access and egress.
- Remaining equipment oils will be drained and recycled prior to final demolition. Re-usable uncontaminated and/or decontaminated equipment will be removed and sold, where possible. Due to the high cost of decontamination and the limited resale value, the majority of equipment from the mill circuits will be disposed of according to the detailed disposal plan (Section 5.1.1)
- As the boilers and generators are taken out of service, they will likely be sold as they are not contaminated and have reasonable re-sale value. If a buyer cannot be found, they will be disposed of in the JEB TMF or Sue C/A pit (revenue from the sale of salvaged equipment has not been considered in the decommissioning cost estimate).
- Concrete foundations that extend above ground level will be removed and disposed of in the JEB TMF or Sue C/A pit. This will be accomplished using a combination of the following methods: blasting, which will be conducted in compliance with The Saskatchewan Mines Regulations and Canada Occupational Health and Safety Regulations; hydraulic ram mounted on an excavator; or by wrecking ball.
- The concrete floor slab is thick (1 m or more in some places) and heavily reinforced. Based on the location, thickness, and amount of rebar, this concrete may be impractical to remove. The floors will be drilled and blasted on a maximum 3 m grid to fracture the concrete or cracked on a similar pattern by use of a hydraulic ram. For areas with potential for contamination under the slab, the concrete will be removed, and the soil assessed. If found to be above decommissioning criteria, the concrete will be removed and the contaminated materials disposed of in the JEB TMF or Sue C/A pit, as deemed appropriate. Areas that meet decommissioning criteria, fracturing of the slab will promote drainage and root establishment. The fractured concrete will be covered with a minimum of 0.3 m of till and re-vegetated.

- Concrete pads and ramps will be fractured and covered or removed depending on the thickness, amount of rebar, and level of contamination. Material removed will be disposed of in the JEB TMF or Sue C/A pit.
- Elevated structures will be left in a stable condition as long as possible with completion of each structure expedited once it is weakened beyond a stable condition. The area will be barricaded and guarded during the demolition of these structures.
- During the demolition of contaminated areas, the materials being demolished or readied for transport will be wetted down to prevent dust migration.
- In-ground tanks and sumps will be emptied and washed out. The excavations will be backfilled to surface with clean till. Tanks that are identified as non-salvageable will be crushed and disposed of in a suitable location, such as the JEB TMF or Sue C/A pit.

The main equipment utilized for mill demolition will likely consist of tracked backhoes with various bucket, clam shell, shear, grapple, and hydraulic ram attachments, bulldozers, front end loaders, skid steer with grapple attachment, and haul trucks. The cost estimate for decommissioning the McClean Lake Mill applies a fixed rate per square meter for demolition of the mill complex (Appendix B, Table B2.3). This rate is based on Orano's experience for the contracted demolition of the Cluff Lake uranium mill, a facility similar in scale and complexity.

Due to the high cost associated with decontaminating and sorting potentially salvageable equipment or materials within the mill complex, the majority of these materials will be disposed of in the JEB TMF or Sue C/A pit. The demolition rate represents an aggregate cost per square meter of the total cost to decommission the Cluff Lake Mill including removal of interior equipment, piping, and electrical disconnects, removal of exterior cladding, demolition of the structure, fracturing of the concrete slab, and hauling of waste for in-pit disposal. As the methodology for decommissioning the McClean Lake Mill is similar to the Cluff Lake Mill decommissioning, the application of this aggregated rate is considered reasonable for approximating relative demolition costs.

Rubble volumes anticipated to result from mill demolition are calculated in Appendix B, Table B2.15 Material Quantities, with estimated rates for hauling and disposal of rubble provided in Table B2.13 General Equipment Rental Rates. Hauling and disposal of rubble represents approximately 10% of the aggregated demolition cost. The remaining 90% is allocated to active demolition of the mill complex that includes dismantling of equipment, tanks, and piping, electrical disconnects, building cladding removal, structural steel demolition, and fracturing of the concrete slab.

Mill Site Runoff Pond

Contaminated sediment and liner within the sump, the wet well and the access platform will be removed and hauled to the JEB TMF or Sue C/A pit for disposal. The depression will be backfilled with clean waste rock material and capped with a minimum of 0.3 m of clean till to match the surrounding topography.

Buried pipelines will be flushed, capped and left in place. Accessible pipelines will be cut into manageable lengths, after first being purged with clean water and blown out, and then disposed of in the JEB TMF or Sue

C/A pit. All water will be captured and directed for treatment at the JEB WTP or contained and transported off site for treatment.

Temporary Sludge Ponds

The sludge from these ponds results from the CX plant and contains ammonia. These sludges will be disposed of into the Sue C/A Contaminated Landfill. The liner material will be cut into manageable pieces and transported to the Sue C/A Contaminated Landfill. Material under the liner will be checked for contaminants and impacted material will be excavated and disposed of in the JEB TMF or Sue C/A pit. The elevated berms of the sludge ponds will be cut down to ensure the topography blends into the general surroundings. Slopes will generally be maintained at less than 3H:1V. Berm material surrounding the liner will also be re-contoured.

Clean Laydown Area

Clean materials stored within this area will be salvaged, sold, donated, or recycled at an offsite facility if feasible, and otherwise disposed of in either the industrial or Sue C Contaminated Landfill or Sue C/A pit. The area will then be scarified and re-vegetated.

Warehouse Cold Storage Building and Compound

The pole-shed cold storage building will be demolished and disposed of in the industrial landfill or the JEB TMF or Sue C/A pit. Surplus materials within the compound will be sold or donated to local communities. Remaining materials that cannot be salvaged, such as fencing and racking, will be disposed of in the industrial landfill, the JEB TMF or Sue C/A pit.

Propane Bullets

The tanks and associated lines will be purged with an inert gas prior to decommissioning. After purging, underground lines will be capped below ground level. The propane tanks will be removed and returned to the vendor prior to final decommissioning. The tank supports and related piping will be recycled or disposed of in the JEB TMF or Sue C/A pit. The distribution structure, vaporizers and bottled gas storage building will be demolished and disposed of in either the industrial or Sue C Contaminated Landfill, the JEB TMF or the Sue C/A pit. The remaining foundations will be fractured and covered with till to blend in with the surrounding terrain.

Hazardous Materials Storage Pad

Materials classified as hazardous wastes will be shipped offsite for disposal or recycling at licensed facilities during the post-operational clean up period. The storage enclosures on the hazardous materials pad will be cleaned and salvaged. The concrete pad will be fractured and disposed of in the JEB TMF Sue C Contaminated Landfill or Sue C/A pit along with underlying contaminated soils.

The Post-Operational Hazardous Materials Cleanup cost estimate, provided in Table B1.3 of Appendix B, outlines the cost for removal of nuclear gauges from the mill, the inventory of miscellaneous wastes stored on the hazardous materials storage pad, waste oils, and residual bulk reagents after shutdown of the mill. Some reagents will continue to be utilized for water treatment and remaining chemical inventory will be returned to

suppliers after final decommissioning of the water treatment plants. The cost of managing this inventory is captured in Table B2.19 as part of general site maintenance costs.

Services Shop & Office

Remaining construction materials will be sold, donated, or disposed of in the industrial landfill. The steel foldaway building and side sheds will be demolished, if not salvageable, and disposed of in either the industrial or Sue C Contaminated Landfill, the JEB TMF or the Sue C/A pit. The concrete pad will be fractured and covered with a minimum of 0.3 m of till.

JEB Mechanical Shop and Equipment Storage

Hazardous materials such as stored oils, lubricants, and glycols will be transferred to the hazardous materials storage pad prior to being shipped offsite for disposal or recycling. The waste oil tank will be drained and purged. If not salvageable, the tank will be crushed and disposed of in the JEB TMF or the Sue C/A pit. The maintenance shop and connected heavy equipment storage building will be demolished and disposed of in either the industrial or Sue C Contaminated Landfill, the JEB TMF or the Sue C/A pit. The concrete foundation will be fractured and covered with 0.3 m of till and graded to match the surrounding topography.

Ancillary Buildings

The buildings in this planning envelope that will require demolition are the training building, temporary contractor office buildings (trailers), safety and construction trailers, concrete batch plant structure, and various temporary fabric covered structures. These areas will have been minimally impacted by mill contaminants. Ancillary buildings will be dismantled and salvaged if they are free of radiological contamination, where possible, or demolished and disposed of in either the industrial or Sue C Contaminated Landfill or the Sue C/A pit. The training building's concrete foundation and the concrete pads under the fabric covered structures will be fractured and covered with 0.3 m of till and graded to match the surrounding topography. The areas will be scarified and re-vegetated.

The fabric covered buildings used to store environmental field equipment and supplies will remain in use throughout decommissioning activities to support the environmental monitoring program. During the later stages of decommissioning, the buildings will be removed, and materials will be salvaged or disposed of in either the industrial or Sue C Contaminated Landfill or the Sue C/A pit. The concrete pad underneath will be fractured and covered with 0.3 m of till and graded to match the surrounding topography.

Fuel Tanks

The fuel tanks will be emptied and remaining excess fuel will be transferred to a designated temporary fuel tank that will be used for power generation and mobile equipment supply during decommissioning activities. The tanks and distribution equipment will be purged and cleaned of fuels. If not salvageable, tanks will be crushed and disposed of in either the industrial or Sue C Contaminated Landfill, the JEB TMF or the Sue C/A pit. Waste products from cleaning will be transferred by vacuum truck and stored on the hazardous materials pad to be shipped offsite for recycling or disposal. A fireguard will be maintained during dismantling of the distribution

system and fuel tank demolition. The concrete pad will be fractured and hauled to the JEB TMF or the Sue C/A pit in order to assess potential underlying soil contamination. Soil samples will be collected, and hydrocarbon contaminated soil will be excavated and remediated in the hydrocarbon landfarm.

Calumet Tanks and Anhydrous Ammonia Tanks

The calumet and anhydrous ammonia tanks at the McClean Lake Mill will be drained and purged. A fireguard and safety personnel will be maintained during this process. The cleaned tanks will be salvaged; if possible, otherwise the tanks will be crushed and disposed of in the JEB TMF, Sue C Contaminated Landfill or the Sue C/A pit.

JEB Water Treatment Plant

The JEB WTP will be required to treat porewater expelled during the tailings dewatering and tailings consolidation phase of the JEB TMF. The JEB WTP will be one of the last facilities to be decommissioned after tailings consolidation is complete, prior to construction of the final cover on the JEB TMF. The JEB WTP will be demolished in a similar manner to McClean Lake Mill complex components noted above, with the majority of materials disposed of in the JEB TMF or Sue C/A pit.

JEB WTP sludges generated during the decommissioning period will be deposited in the JEB TMF, Sue C Contaminated Landfill or Sue C/A pit prior to construction of the final cover. Further discussion on WTP sludge is included in Planning Envelope #3 – JEB TMF.

Monitoring Ponds

Sludge remaining in the ponds will be transported to the JEB TMF or Sue C/A pit and then the three monitoring pond liners will be cut into manageable pieces and disposed of in the JEB TMF, Sue C Contaminated Landfill or Sue C/A pit. Material underneath the pond liners will be assessed for radiological contamination and excavated and disposed of in the JEB TMF, Sue C Contaminated Landfill or Sue C/A pit. Re-contouring of the monitoring pond berms will blend the topography into the general surroundings. Slopes will generally be maintained at less than 3H:1V.

Powerhouse

The powerhouse generators will continue to supply emergency power for the JEB WTP, dewatering system, Sue WTP, and temporary camp facility during decommissioning activities. At the time decommissioning of these facilities is conducted, mobile power generation will be used to supply power for the temporary camp. The generators will be resold, and the underlying thick concrete pads will be fractured, covered with till, and re-vegetated.

Utilities & Pipelines

The outdoor electrical distribution system on the McClean Lake Mill terrace will be dismantled and non-contaminated materials will be salvaged and resold. Materials which are contaminated or were located in a

contaminated area will be disposed of in the JEB TMF, Sue C Contaminated Landfill or Sue C/A pit. Transformers will be drained of oils and shipped offsite for recycling.

McClellan Lake Mill Terrace & Roadways

The roadways and general grounds around the mill terrace will be graded to remove surface contamination and the contaminated soil will be deposited into the JEB TMF, Sue C Contaminated Landfill or Sue C/A pit. Following subsequent radiological surveys, residual contamination will be removed or covered with clean till to a depth sufficient to meet final radiological criteria. Culverts will be removed and replaced with cross ditches for drainage. Roadways will be scarified before abandonment to promote re-vegetation.

5.3.3 Planning Envelope # 3: JEB Tailings Management Facility

The JEB Tailings Management Facility (TMF) planning envelope (Figure 3) primarily includes the JEB TMF and associated infrastructure. The decommissioning financial summary for Planning Envelope # 3 – JEB TMF is provided as Table B2.4 of Appendix B.

5.3.3.1 Description

Tailings from the milling process must be carefully managed to minimize potential adverse interactions with the environment during the operational, decommissioning, and post-decommissioning phases of the facility. Decommissioning of the JEB TMF is an important element in the overall decommissioning plan for the McClellan Lake Operation to ensure long-term performance objectives for the TMF are achieved. Information is presented below for the expected scenario at the end of this 5-year planning period (2030) The financial calculations are based on decommissioning requirements at the end of this 5-year period. A preliminary decommissioning schedule is described in Section 5.5.

The JEB TMF is designed and operated to provide stable physical containment of tailings and to reduce the migration of soluble constituents from the JEB TMF to the receiving environment throughout operations, decommissioning, and the post-closure period. The natural surround design, combined with control of the tailings geotechnical and geochemical properties during tailings preparation, is employed as a passive method to limit the long-term release of constituents of potential concern (COPC) from the decommissioned facility. The tailings preparation circuit associated with the McClellan Lake Mill is used to treat and neutralize tailings for the control of COPCs in the tailings pore water and to thicken the tailings. The resulting tailings slurry is then pumped from the McClellan Lake Mill to the JEB TMF. When consolidated, the target hydraulic conductivity of the tailings mass is designed to be at least two orders of magnitude less than that of the surrounding fractured natural sandstone. Under these long-term conditions, the consolidated tailings represent a low-permeability material, and therefore, groundwater will preferentially flow around the tailings mass through the surrounding more permeable host rock (Orano 2025e). Groundwater flow and contaminant transport modelling is updated every five years to predict potential effects downstream of the JEB TMF. The results of the modelling and studies are provided in Section 7.4.4 of the McClellan Lake Operation Tailings Management TID.

Hydraulic containment, as is used during current operations, will be employed during the post-closure period to prevent the outward migration of COPC from the JEB TMF while the tailings are dewatered to reach their final consolidated state. Hydraulic containment is achieved by maintaining a hydraulic head differential between the raise water drift, under the base drain, and the surrounding groundwater, using Fox Lake as a reference elevation. Previously, hydraulic containment of the JEB TMF was controlled through a combination of pumping from a perimeter ring of dewatering wells, water reclaim pumping from the JEB TMF pond and the base drain. The purpose of the dewatering wells was to intercept and divert clean groundwater entering the JEB TMF to reduce the amount of water requiring treatment, and to control water levels within the JEB TMF. The dewatering well infrastructure has been progressively decommissioned since 2017 to allow for the optimization and expansion of the JEB TMF. Pumping from the base drain alone is sufficient to maintain hydraulic containment. Further details regarding the base drain pumping and decommissioning of dewatering wells can be found in Section 2.4.3.2 of the McClean Lake Operation Tailings Management TID. A discussion of the hydraulic containment over time can also be found in Section 2.2.2. of the McClean Lake Operation Tailings Management TID.

TMF Capacity

JEB TMF Optimization: rendering the use of the dewatering wells ineffective. Certain dewatering wells and associated infrastructure were within the construction footprint of the JEB TMF Optimization necessitating decommissioning. Starting in 2017, select dewatering wells and associated infrastructure were decommissioned and hydraulic containment is now maintained through pumping from the raise water system. The first JEB TMF Optimization Project was completed in October 2018. A bentonite amended soil liner was constructed on the re-sloped overburden within the JEB TMF to an elevation of 443 mASL. As-built records of construction were provided to the CNSC and SMOE (Golder 2019). Successive liner expansion campaigns have increased the elevation. As a result of the JEB TMF Optimization project, the pond level of the JEB TMF was raised above the sandstone/till contact.

JEB TMF Expansion: An application to expand the JEB TMF to provide consolidated tailings storage to 448 mASL, the approximate low point of the natural ground elevation, through the construction of an embankment to an elevation of 457.5 mASL was accepted by the CNSC in 2017 and the SMOE in 2018. The JEB TMF Expansion project provides the ability to place and store tailings above the level of the sandstone/till contact through the construction of an embankment around the JEB TMF perimeter and extension of the existing soil bentonite liner to contain the pond water above the tailings during the operating period. Embankment and liner expansion activities occur in stages. The expansion construction of the embankment was completed in 2021. As-built records of construction were provided to the CNSC and SMOE (Golder 2021). The most recent soil bentonite liner raise was completed in 2023 to an approximate elevation of 452.5 m ASL. The 2023 record of construction report was provided to the CNSC and SMOE (WSP 2023).

5.3.3.2 Preliminary Decommissioning Approach

JEB TMF

The decommissioning strategy for the JEB TMF is the permanent in-situ confinement of the tailings, as noted above. A four-stage progressive decommissioning plan implemented approximately two years before the end of mill operations is described below.

Stage 1

Preparation for placement of the waste rock surcharge and construction of the top drain leachate collection system will begin during final deposition of mill tailings. Placement of tailings will be controlled to achieve a level to slightly mounded tailings surface. The tailings water cover maintained during operations will be progressively reduced during the last year of operations or during initial decommissioning to achieve a minimum water cover sufficient to operate the tailings deposition system. This water will be pumped to the JEB WTP for treatment prior to discharge to the S/V TEMS. When the tailings have been leveled and distributed, and the water cover reduced, placement of the waste rock fill will commence.

Stage 2

Following final placement of tailings and shutdown of the McClean Lake Mill, the tailings surface will be prepared for placement of the waste rock surcharge. The surface of the tailings can be expected to be unconsolidated and relatively soft. Placement of rock directly on the freshly placed tailings may cause the rock fill to sink into the tailings displacing them. To prevent this, it is proposed that an approximate 2 m layer of sand fill will first be placed over the tailings surface to act as a support filter. A 2 m thick layer of drain rock will then be placed over the sand layer. If there is standing water over the sand support layer, the rock will be placed in a uniform layer onto the ice cover during winter. The rock will settle uniformly onto the sand surface during the following spring thaw.

Tailings Pore Water Treatment

During decommissioning of the JEB TMF, active dewatering of tailings will be required until consolidation is achieved. The tailings are estimated to reach a consolidation endpoint in approximately 10 years, at which time the final cover will be constructed.

Once the shutdown process of the McClean Lake Mill is complete, the JEB TMF will continue to be actively dewatered by pumping from the existing raise well system with resulting water treated at the JEB WTP. Consolidation of the tailings mass will be enhanced by removal of the JEB TMF operating pond and addition of a surcharge of clean waste rock onto the tailings surface. A water collection system will be constructed within this clean waste rock to serve as a top drain for collection of expelled tailings pore water. Tailings pore water will continue to be drawn out through both the base drain and top drain and treated at the JEB WTP. Water treatment operational costs for the 2-year post-operational phase are included in Table B1.2 of Appendix B. Water treatment costs for the estimated 10-year active tailings dewatering and consolidation phase are included in Table B2.4 of Appendix B.

Sludges produced from the treatment of contaminated waters during decommissioning will be placed in a disposal area prepared within the JEB TMF. The location will be selected to ensure that the WTP sludge will be situated in the upgradient portion of the TMF. Runoff from these sludges will be collected through the tailings

upper drainage system along with tailings pore water and treated at the JEB WTP. Upon achieving a consolidated tailings mass and subsequent shutdown of the JEB WTP, the sludges deposited in the JEB TMF will be covered with clean waste rock as part of final cover construction activities.

A water collection system will also be constructed to allow consolidation flows related to pore fluid seepage to be recovered and treated. The water collection system will consist of perforated corrugated steel or HDPE wells installed in a granular blanket within the waste rock fill material. Collected water will be pumped to the JEB WTP for treatment. Vibrating wire piezometer and volumetric water content instrumentation will be installed within the tailings to provide pore water pressure dissipation and consolidation performance to be monitored during and after cover construction.

Tailings Pore Water Monitoring

Instrumentation will be installed at various locations within the tailings to monitor the rate of dissipation of induced pore water pressures during consolidation. Once pore water pressures have reduced to normal levels (hydrostatic), the majority of the pore water has been expelled and the tailings mass will be consolidated to a degree that allows the till cover to be constructed.

The tailings pore water collection system installed in the top drain will be monitored for water chemistry and for volume of water removed by pumping. Additionally, pore water will be sampled during the final TOVP sampling program to confirm that COPC concentrations align with decommissioning objectives.

The raise well will continue to collect a limited amount of expelled pore water as consolidation nears completion. Water quality and volumes removed through the raise well will also be monitored. The natural groundwater elevation is expected to re-establish at approximately three meters below the final reclaimed surface of the JEB TMF. Groundwater elevation will be monitored through the monitoring well network surrounding the JEB TMF until equilibrium is established.

Periodic surveying of the final backfilled pit surface will be necessary during consolidation. Settlement will occur as a result of consolidation of tailings and, to a lesser degree, backfill material. Surveying will confirm that adequate waste rock has been placed to ensure positive surface drainage. Should excessive settlement be observed in certain locales, additional material will be placed to adequately re-contour the cover. Only minor maintenance of the top drain is expected from differential settlement as it will be constructed from drain rock. No major disruptions to the system or consolidation are expected from any maintenance of the drain system or excavation to access the drain rock.

Decommissioning of the JEB TMF will be considered complete when:

- pore water pressures have sufficiently dissipated indicating that the tailings mass has achieved sufficient consolidation;
- tailings pore water chemistry is trending as predicted within an acceptable range of COPC concentrations, which will result in mass loadings that will not significantly impact the water quality of surface water receptors; and,

- the final reclaimed surface remains slightly mounded to promote adequate surface drainage and vegetation is self-sustaining.

Stage 3

The third stage of JEB TMF decommissioning will consist of placement of a thick, clean waste rock cover. Sufficient rock will be placed in a mounded configuration to accommodate the anticipated consolidation settlement. Consolidation will expel tailings pore fluid that will be collected in the tailings surface collection system and the basal drain. A hydraulic head differential in the basal drain will be maintained below the tailings surface elevation to promote consolidation and to ensure that expelled pore water is contained. Water pumped from the JEB TMF during consolidation of tailings will be treated before discharge and recovered sludges disposed of by burial in a designated area on the up-gradient side of the JEB TMF.

With ongoing settlement, re-contouring of the Stage 3 waste rock cover will be performed as necessary to maintain a well-drained surface.

Stage 4

When pore pressure monitoring indicates that tailings consolidation settlement has achieved the desired endpoint, a compacted soil bentonite cover will be constructed over the waste rock. A finish material, consisting of stockpiled organic material from TMF expansion will be placed, graded for positive runoff drainage, and re-vegetated. Figure 4 presents a conceptual cross section through the decommissioned JEB TMF. The final cover will consist of clean waste rock with a compacted soil bentonite cover and finish material. At the same time, the water treatment plant sludge disposal area will be decommissioned, covered with till material, and re-vegetated.

Contaminated Materials

Contaminated materials determined to be appropriate for disposal in the JEB TMF in the detailed disposal plan (Section 5.1.1), will be transferred to the JEB TMF for disposal during Stage 3 decommissioning activities. These materials will be placed within the waste rock fill above the tailings mass and below the final waste rock and till cover.

Perimeter Dewatering Wells

Dewatering well pumps have been removed and disposed of in the JEB industrial landfill. Concrete bunkers were removed and relocated to the brow of the Sue C/A pit for future disposal. The raise wells will be decommissioned and disposed of in the industrial landfill or Sue C pit, as appropriate, and the standpipes capped below grade. The remaining well enclosures, raise water pumphouse building, and the pressure control station will be demolished and disposed of according to the detailed disposal plan (Section 5.1.1).

Contouring and re-vegetation of the JEB TMF area will occur during final contouring and re-vegetation of the JEB TMF cover.

5.3.3.3 Final JEB TMF Configuration

For informational purposes, decommissioning of the anticipated future scenario at the end of the operational phase is also discussed. In 2022 the CNSC approved Orano's application for JEB TMF expansion up to 468 mASL. This allows for storage of unconsolidated tailings to 465.5 mASL with a final approved consolidated tailings elevation of 462 mASL. The JEB TMF currently has an embankment elevation of 457.5 mASL and a soil bentonite liner elevation of 452.5 mASL.

The final decommissioned JEB TMF facility assumes full backfilling of the JEB TMF above the tailings mass. A soil cover system and closure landform have been designed for the JEB TMF (Golder 2011a and 2011b). Details on the cover design are included in section 4.4.2.4 of the McClean Lake Operation JEB TMF Expansion (468 mASL) Project Description report. The general cover profile is as follows:

- clean waste rock and filter material above the tailings;
- a soil bentonite amended barrier layer to limit the infiltration of water above the waste rock and filter material; and
- a final surface layer to influence water evaporation, plant transpiration and horizontal movement of water.

The JEB TMF embankment slopes will be regraded flatter than the operating slope. This, combined with the topography of the final surface layer of the cover will aid to achieve the performance objectives of the cover system.

Based on the current projected production schedule, approximately 3,049,936 tonnes of tailings are anticipated to be produced in the 5-year planning period to the end of 2030. Applying an average consolidated dry density of 1,100 kg/m³ (COGEMA 2004b); the tailings will occupy a volume of approximately 3,049,936 m³ and fill the JEB TMF to an approximate elevation of 447 mASL before consolidation. Applying a 10-meter assumption for consolidation results in a final consolidated elevation of approximately 437 mASL. The remaining storage volume will be filled with material currently stored in the JEB overburden and clean waste rock stockpiles, and with contaminated equipment and materials from demolition of the McClean Lake Mill and other infrastructure. Material would also be added as the embankment slopes are flattened, excess material would be used for backfill over the tailings and below the soil bentonite layer. Considering the total volume of the tailings facility to surface, approximately 1,250,000 m³ of material would be back-hauled to the JEB TMF during decommissioning in order to fill the facility to surface in preparation for cover placement. Figure 4 presents a conceptual cross section through the decommissioned JEB TMF. Further details on the tailings consolidation can be found in Section 5.6 of the McClean Lake Operation Tailings Management TID.

5.3.3.4 Tailings Contingency

The load associated with backfill and cover material will provide a confining stress to promote consolidation of the tailings to a density and hydraulic conductivity that minimizes flow of groundwater through the tailings mass. By minimizing groundwater flow through the tailings, advective transport of solutes will be controlled and the

relatively slow process of molecular diffusion will constitute the primary mechanism for solute transport from the decommissioned facility (Orano 2025e).

The installation of a low-permeability soil cover above the tailings mass is available as an option to mitigate potential effects related to accumulations of coarse zones within the central core of the tailings mass. The low-permeability cover would be installed at the top of the tailings surface below the top filter and drain system. The cover would serve to reduce flux of surface infiltration through the tailings mass and to reduce the vertical component of groundwater flow through the tailings mass. Various methods of creating a low permeability cover may be employed including amending the top layer of tailings or installation of an engineered soil cover.

5.3.4 Planning Envelope # 4: Camp Area

5.3.4.1 Description

The camp area planning envelope (Figure 3) includes all the camp facilities and associated infrastructure located at the JEB site. The financial summary for Planning Envelope #4 –Camp Area is provided as Table B2.5 of Appendix B.

The camp planning envelope includes the following infrastructure:

- Modular trailer dorms – four of the remaining dorms (G, H, I, and J dorms) in the permanent camp are constructed from modular trailers. They are located on the perimeter of the permanent camp complex.
- dorms, kitchen, and gymnasium – four dorms (A, B, C, and D dorms), a commercial kitchen with cafeteria, and gymnasium are located in the permanent camp complex.
- Incinerator – the domestic waste incinerator is located immediately south of the permanent camp kitchen.
- Potable water treatment plant – the camp potable water treatment plant provides the camp complex with treated water for potable purposes.
- Pat Lake pumphouse – the Pat Lake pumphouse is the freshwater source for the McClean Lake Operation.
- Propane bullet – the propane bullet is located east of G & H dorm trailers, it is used to provide heat for the permanent camp complex, with the exception of C dorm which is heated geothermally.
- Generator and fuel tank – the diesel generator is used as back-up power supply during power outages.
- Recreation facilities – Pat Lake dock and tennis court.

- Associated roads, pipelines, and utilities.

5.3.4.2 Preliminary Decommissioning Approach

Modular Dorms

If salvageable, the modular trailer dorms will be sold or donated to local communities. Otherwise, they will be demolished and deposited either in the industrial landfill or the JEB TMF. Select modular trailers were either removed from site or moved to the top of the waste rock pile in preparation to be landfilled (K and L dorm) in recent years.

Dorms, Kitchen, and Gymnasium

Contamination of camp infrastructure and equipment is anticipated to be negligible due to contamination control measures in place throughout operations. Engagement with northern communities prior to decommissioning will identify equipment or materials that may be donated or otherwise reused. Deferred removal will be the strategy for one of the four permanent dorms, the potable water treatment plant, the emergency generator and fuel tank, and the Pat Lake pumphouse due to their required use during active decommissioning.

The majority of the camp facilities salvageable materials and equipment, such as the kitchen appliances, recreation equipment, and the generator, could potentially be donated to communities, as determined through engagement. The permanent camp buildings, being predominantly wood frame and cement or foam block structures, will be demolished and disposed of in the industrial landfill. Non-saleable items will be recycled or disposed of in the industrial landfill or JEB TMF, as appropriate. The propane tank will be returned to the vendor and propane lines will be purged and disconnected.

Incinerator

The incinerator is used to incinerate mainly food and unrecyclable domestic waste in order to divert this waste from the landfill and deter wildlife interaction. The incinerator will be cleaned and sold. The incinerator building will be demolished for disposal in the industrial landfill, the Sue C/A pit or the JEB TMF. The concrete pad will be fractured, covered with a minimum of 0.3 m layer of till, and re-vegetated.

Potable Water Treatment Plant

Salvageable equipment from the potable water treatment plant will be sold, donated, or recycled. The building structure will be demolished and recycled, and remaining materials disposed of in the industrial landfill, the Sue C/A pit or JEB TMF. The cistern will be backfilled with clean till.

Pat Lake Pumphouse

The Pat Lake pumphouse will be demolished after removal of salvageable and recyclable materials. The intake pipe, anchors and intake screen will be removed from Pat Lake. Demolition material will be recycled where possible or disposed of in the industrial landfill, the Sue C/A pit or the JEB TMF. Concrete footings will be broken

to ground level and the remaining concrete fractured into maximum 3 m square slabs. After removal of the demolition material, the building site will be covered with a minimum of 0.3 m of clean till and contoured to resemble the general surroundings.

Propane Bullet

The propane bullet and associated lines will be purged with an inert gas prior to dismantling. After purging, underground lines will be capped below ground level. The propane tank will be removed and returned to the vendor. The tank supports and related piping will be recycled or disposed of in the JEB TMF.

Generator

The generator will be sold once it is no longer required to provide power for remaining camp facilities during decommissioning activities. The fuel tank will be purged and salvaged; otherwise, it will be disposed of in the JEB TMF.

Recreation Facilities

The Pat Lake dock and boathouse will be dismantled and donated to a northern community. The tennis court asphalt surface will be removed and disposed of in the industrial landfill. Fencing will either be salvaged or disposed of in the industrial landfill or the Sue C/A pit.

Associated Roads, Pipelines, and Utilities

Underground lines will be purged and left in place with caps placed on accessible ends. The geothermal heating system for the C dorm will be purged and the wells capped below grade. All water will be captured and directed for treatment at the JEB WTP or contained and transported off site for treatment.

5.3.5 Planning Envelope # 5: Sue Mining Area

5.3.5.1 Description

The Sue mining area includes all of the facilities at the Sue site (Figure 5) that are associated with former mining activities but exclude the support facilities detailed in Planning Envelope #6. The decommissioning financial summary for Planning Envelope #5 – Sue Mining Area is provided as Table B2.6 of Appendix B.

The Sue mining area planning envelope includes the following infrastructure and facilities:

- Sue Ore Transfer Pad & Lined Runoff Collection Ditch;
- Sue Pre-Sedimentation Ponds (3);
- Diversion Ditches;
- Sue C/A Pit;

- Sue C Contaminated Landfill
- Sue C Clean Waste Rock Stockpile;
- Sue C Overburden Stockpile;
- Sue E Pit;
- Sue E Clean Waste Rock Stockpile;
- Sue E Overburden Stockpile;
- Sue B Pit;
- Ore Scanner;
- Sue Industrial Landfill;
- Heavy Equipment Boneyard;
- Storage buildings; and,
- Associated Pipelines, Roads, Culverts, and Power lines.

5.3.5.2 Preliminary Decommissioning Approach

Sue Ore Transfer Pad

Remaining ore will be hauled and processed through the McClean Lake Mill. Alternatively, ore not processed will be placed and capped as required into the Sue C/A pit or Sue C Contaminated Landfill depending on volume and available space. Stored sludges that cannot be processed through the McClean Lake Mill will be hauled to the Sue C/A pit, Sue C Contaminated Landfill or the JEB TMF for disposal. The HDPE liner material will be cut into manageable pieces and disposed of in the Sue C/A pit or Sue C Contaminated Landfill. The underlying soil will be checked for radiological contamination and residual contaminated material will be removed to either the Sue C/A pit, JEB TMF, or covered with clean till to a depth sufficient to meet final radiological criteria. Once radiological objectives are achieved, the area will be scarified and re-vegetated.

Sue Pre-Sedimentation Ponds

The sludge from the three pre-sedimentation ponds will be hauled to the Sue C/A pit or the JEB TMF at the end of Sue WTP operations. Base material underneath the ponds will be assessed for contamination and removed to the Sue C/A pit or covered with clean till to meet radiological criteria, as appropriate. The excavation will be backfilled with clean waste rock and capped with 0.3 m of clean till and contoured to blend into the local topography.

Diversions Ditches

The diversion ditches will be backfilled with clean waste rock or till and re-vegetated.

Sue C/A Pit

Initial dewatering of the Sue area began during mining of the Sue C pit from 1997 until 2002. Groundwater was allowed to flood the Sue C pit until pumping was resumed in June 2004 in preparation for mining of the Sue A pit. Water was pumped from the Sue C/A pit until October 2009, after which it was allowed to flood naturally until 2011. The Sue C/A pit is the largest of the Sue pits with a combined volume of about 11.5 million m³. The placement of special waste from the JEB and Sue pits into the bottom of the Sue C/A pit was completed in 2012. Since 2011, the pit has been naturally re-flooding with seasonal periods of drawdown and water treatment. For the purpose of the PDP it is assumed that a till cap will need to be constructed over the interred waste in order to meet final water quality objectives in the Sue C/A pit. As such, the pit water will need to be drawn down and treated prior to release to the S/V TEMS.

This period of pit water treatment is estimated to require five years in order to draw the water level down such that the surface of the special waste can be accessed to construct the till cover. Once the Sue C/A pit is dewatered, the special waste materials will be covered with a minimum of 1 m of till and the pit will be re-flooded. Pit water quality will be monitored during re-flooding and compared to predictions to ensure end state surface water quality parameters are achieved.

As an alternative, Orano intends to develop a long-term remediation program to improve the water quality in the Sue C/A pit (details in Section 4.2.6). New contaminated waste may be placed into the Sue C/A pit at the time of decommissioning (i.e. unused ore). Where capping is required, an alternative to completely dewatering the pit for capping will be to build dykes locally for the required amount of waste. This way the smaller portion may be dewatered and capped as required.

Sue C Clean Waste Rock Stockpile

The majority of the Sue C clean waste rock stockpile was re-contoured following the end of Sue mining activities. Ultimately, slopes will be less than 3H:1V, however, a few facilities - the industrial landfill and former drill shop - remain to be decommissioned that are located within the footprint of the waste rock stockpile. These facilities will be decommissioned as described in Sections 5.3.5.2 and 5.3.6.2. Upon completion of re-contouring, the stockpile will be re-vegetated. About 18 ha of the recontoured slopes were hydroseeded in 2022-2023. The hydroseeding success will be estimated over the next few years to inform future revegetation planning.

Sue C and Sue E Overburden Stockpiles

The overburden stockpiles will be used to cover areas requiring till fill. Remaining overburden will be contoured to stable slopes generally less than 3H:1V and re-vegetated, as required.

Sue E Pit

Mining of the Sue E pit began with the removal of overburden in September 2005 and was completed on March 15, 2008 (AREVA 2009d). The total volume of the fully mined-out pit is approximately 8.0 million m³. The Sue E pit contains wastes generated from the mining of Sue B pit (exclusive of overburden which was added to the Sue C overburden stockpile). The Sue E pit has been partially backfilled, and the wastes capped with a 2 m lift of clean till. Sue E was allowed to flood naturally with groundwater. Currently Sue E pit water quality at the time of decommissioning is not predicted to be below SEQGs although Site specific targets based on environmental risk assessments will be used to determine the final acceptable water quality in the Sue E pit. Orano has initiated an in-situ remediation program to improve the water quality in the Sue E pit with the goal of improving the Sue E pit water quality. In-situ remediation test work at the Sue E pit is scheduled to start in May 2025 (details in Section 4.2.6).

Sue E Clean Waste Rock Stockpile

The Sue E waste rock stockpile was partially re-contoured during progressive reclamation activities in 2009 and 2010. Drainage was improved and some stockpile slopes graded to less than 3H:1V. Material from the Sue E clean waste rock stockpile is preferred to be used to backfill areas that require large fills in the Sue area. Final contouring and re-vegetation will be conducted during the remaining Sue Mining Area decommissioning.

Sue B Pit

The Sue B pit was the last mined area. Mining of the Sue B open pit began in March 2008 and was completed by November of 2008. The total volume of the fully mined-out pit is approximately 1.7 million m³. A minimum of 2 m of clean till was backfilled to cover exposed ore at the base of the pit and the pit allowed to flood naturally. The Sue B pit receives runoff water from the Sue C clean waste rock stockpile. Sue B water levels have been managed by pumping water into the Sue C/A pit, when necessary. Management of surface runoff is currently being investigated to be able to advance towards a passive decommissioned state for the Sue B pit.

Sue Radiometric Scanner

The radiometric scanner was used during mining to segregate ore from waste rock. Due to the likelihood of contamination, the scanner structure will be demolished along with the scale, building, and concrete ramps and disposed of in the Sue C/A pit or Sue C Contaminated Landfill.

Sue Industrial Landfill

The Sue industrial landfill contains uncontaminated waste generated during mining of the Sue area and is located on the eastern edge of the Sue C clean waste rock stockpile. At closure, the industrial landfill will be covered with a minimum of 2 m of clean waste rock or till material and re-vegetated.

Sue C Contaminated Landfill

A temporary contaminated materials landfill was formerly located adjacent to the JEB TMF. The contents of the JEB TMF Contaminated Landfill were relocated in 2017 to enable the completion of JEB TMF expansion project (Golder 2017). A total of 18,391 m³ of contaminated waste was excavated and hauled to a new, permanent

contaminated materials landfill that was constructed within the Sue C pit (Figure 5). The contaminated landfill is constructed on top of a bench of special waste rock material on the western side of the Sue C pit. A berm was constructed to separate the contaminated landfill from the pit proper to minimize floating debris within the pit.

During decommissioning, contaminated waste will be directed to the Sue C Contaminated Landfill if depending on compatibility with other disposal sites (i.e. Sue C/A pit or JEB TMF) and available space. At decommissioning, exposed contents of the Sue C Contaminated Landfill will be covered with clean waste rock. No further decommissioning is expected to be required. The potential effect of the placement of the process wastes in the Sue C contaminated landfill on the environment has been determined through contaminant transport modelling presented in Section 6.2.3 of Part B of the WR TID

Heavy Equipment Boneyard

The heavy equipment boneyard consists of non-salvageable and contaminated mining equipment and large materials and is located on the western brow of the Sue C/A pit. Equipment has been drained of lubricants and fuels. Boneyard equipment and materials will be disposed of in the Sue C/A pit.

Associated Pipelines, Roads, and Culverts

The majority of HDPE pipelines connecting the Sue E and Sue B pits to the Sue WTP were removed during progressive reclamation activities in 2010. During decommissioning of the Sue mining area, remaining pipelines and culverts will be removed and cross ditches constructed where necessary. All water will be captured and directed for treatment at the JEB or Sue WTP or contained and transported off site for treatment.

5.3.6 Planning Envelope # 6: Sue Site Facilities

5.3.6.1 Description

The Sue site facilities planning envelope (Figure 5) includes the remaining support facilities in the Sue area that are not included in the Sue mining area planning envelope. The decommissioning financial summary for Planning Envelope #6 – Sue Site Facilities is provided as Table B2.7 of Appendix B.

The Sue site facilities planning envelope includes the following infrastructure and facilities:

- Sue Water Treatment Plant (WTP);
- Sedimentation Ponds (2);
- Monitoring Ponds (2);
- Sue Site Runoff Pond;
- Sue Heavy Duty Maintenance Shop and Wash Bay;

- Snake Lake Storage Building;
- Miscellaneous Storage Buildings;
- Fuel Tanks (2), Propane Bullet (1), and Generator; and,
- Associated Pipelines, Roads, and Culverts.

5.3.6.2 Preliminary Decommissioning Approach

Sue Water Treatment Plant

The Sue WTP will be one of the last facilities decommissioned at the Sue site as it is required to treat Sue C/A pit waters during dewatering operations.

Once pit water monitoring indicates confidence in achieving predicted water quality, the Sue WTP will no longer be required. Exterior cladding will be removed prior to dismantling and/or demolishing the internal components. Equipment will be sold or salvaged for recycling, where possible. The building itself will be demolished and non-salvageable materials will be hauled and disposed of in the Sue industrial landfill, Sue C/A pit, or the JEB TMF, depending on the timing of demolition activities. The concrete floors will be fractured on a maximum 3 m grid and covered with a minimum of 0.3 m of clean till.

Sedimentation Ponds

The sludge from the two sedimentation ponds will be transported to the Sue C/A pit or Sue C Contaminated Landfill for disposal based on compatibility modelling. The liner material will be cut into manageable pieces and transported to the Sue C/A pit or Sue C Contaminated Landfill for disposal. Material underneath the liner will be assessed for possible radiological contamination and removed to either the Sue C/A pit or the JEB TMF or covered with clean till to meet radiological criteria, as appropriate. The concrete ramp will be fractured on a maximum 3 m grid and covered with 0.3 m of clean till. Sedimentation ponds will be backfilled and contoured to blend into the general surroundings. Slopes will generally be maintained at less than 3H:1V. Berm material surrounding the liner will also be re-contoured and re-vegetated.

The pump house next to the sedimentation ponds will be demolished and disposed of in the Sue C/A pit. The concrete floor will be fractured on a maximum 3 m grid and covered with a minimum of 0.3 m of clean till. The emergency runoff ditch, designed to divert water from the sedimentation ponds to the Sue C/A pit in the event of an overflow condition, will be backfilled with clean till material.

Monitoring Ponds

The two monitoring ponds' liners will be cut into manageable pieces and disposed of in the Sue C/A pit or Sue C Contaminated Landfill. Material under the ponds' liners will be checked for radiological contamination and contaminated material will either be removed to the Sue C/A pit or covered with clean till to meet radiological

criteria, as appropriate. The berms will be cut and contoured to ensure the topography blends into the general surroundings.

Sue Site Runoff Pond

The Sue site runoff pond's liner will be cut into manageable pieces and disposed of in the Sue C/A pit or Sue C Contaminated Landfill. Material under the pond liner will be assessed for possible radiological contamination and either excavated and removed to the Sue C/A pit or covered with clean till to meet radiological criteria, as appropriate. The depression will be backfilled with rock from the Sue C clean waste rock stockpile and capped with a minimum of 0.3 m of clean till to blend in with the surrounding topography.

Sue Heavy Duty Maintenance Shop and Wash Bay

Hazardous materials such as stored oils, lubricants, and glycols will be shipped offsite for disposal or recycling by an approved vendor. The waste oil tank will be drained and purged. If not salvageable, the tank will be crushed and disposed of in the Sue C/A pit.

The exterior cladding will be removed from the buildings steel structure and internal salvageable components will be recycled. Remaining materials will be hauled to the Sue C/A pit for disposal. Soils contaminated with hydrocarbons will be remediated at the JEB hydrocarbon land farm. The thick concrete floor slab will be fractured on a maximum 3 m grid spacing and covered with a minimum 0.3 m till cover and graded to match the surrounding landscape.

Snake Lake Storage Building

The Snake Lake storage building is a tin clad insulated structure utilized as an auxiliary warehouse and storage facility. The decommissioning strategy will be similar to that detailed for the maintenance shop noted above.

Miscellaneous Buildings

Two fabric covered buildings, one foldaway steel structure building used for storage, and auxiliary trailers will be dismantled and sold or, alternatively, demolished and disposed of in the Sue C/A pit. Concrete pads will be fractured and covered with a 0.3 m layer of till.

Fuel Tanks, Propane Bullet, and Generator

The two fuel tanks will be cleaned and sold, salvaged, or disposed of in the Sue C/A pit. Waste products from cleaning will be removed by vacuum truck and transferred to the JEB hazardous materials pad for offsite recycling or disposal.

The propane bullet will be removed and returned to the vendor. The associated lines will be purged with an inert gas prior to decommissioning. Tank supports and related piping will be disposed of in the industrial landfill or the Sue C/A pit. The distribution structure and vaporizers will also be removed to the landfill or Sue C/A pit and remaining foundations will be broken and covered with clean fill to blend in with the surrounding terrain. Underground propane lines will be capped below ground level after purging.

Associated Pipelines, Roads, Culverts

Remaining pipelines and culverts will be removed and disposed of in the industrial landfill, or the Sue C/A pit and cross ditches constructed where required. Once facilities are decommissioned, disturbed areas at the Sue site will be scarified and re-vegetated.

5.3.7 Planning Envelope # 7: Sink/Vulture Treated Effluent Management System

5.3.7.1 Description

The Sink/Vulture Treated Effluent Management System (S/V TEMS) (Figure 6) comprises Sink Reservoir, the Sink Reservoir dam, the Sink/Vulture outflow control structure, Vulture Lake, Vulture/McClean outflow control structure and diffuser, and associated access roads and effluent pipelines. Treated effluent from the JEB and Sue WTPs is discharged into Sink Reservoir and through controlled release is discharged into Vulture Lake and subsequently into McClean Lake.

The decommissioning financial summary for Planning Envelope #7 – S/V TEMS is provided as Table B2.8 of Appendix B.

5.3.7.2 Preliminary Decommissioning Approach

Both the Sue and JEB WTPs will continue to discharge treated effluent to the S/V TEMS throughout the interim monitoring period as a result of pit dewatering activities (Sue) and tailings consolidation pore water (JEB). Decommissioning of the S/V TEMS will coincide with final decommissioning of the JEB and Sue WTPs after treated effluent discharges cease.

Sink Reservoir

Decommissioning of the Sink Reservoir will be undertaken to disturb the lake sediments as little as possible with a thorough understanding of attenuated COPCs. Lessons learned from understanding sediment attenuation in downstream receptor lakes at the Cluff Lake Operation will be applied to manage the long-term stability of the Sink Reservoir.

An iron-oxide stained area exists near the JEB WTP treated effluent discharge point into Sink Reservoir. In previous versions of the PDP, a layer of till was proposed to cover the area of iron precipitation. However, this approach has been removed as a wetland area is located between the JEB WTP treated effluent discharge point and Sink Reservoir. The attenuation properties of this wetland area have begun to be assessed to have a complete understanding of the local attenuation of COPCs. Prior to decommissioning studies will be conducted to determine the best path forward to fully leverage the absorptive capacity of the wetland and minimize disturbance to any attenuated COPCs. While the till cover is no longer being advanced, the associated cost estimate in Table B2.8 will be retained as a budgetary placeholder until a revised approach is determined. Future PDP versions will be updated to include a rationale and a revised cost estimate once an approach has been determined.**Sink Reservoir Dam**

The plan to decommission the Sink Reservoir dam is to breach the structure at three locations, one near each shoreline and the third in the location of the weir control structure. Studies and risk assessments will be completed prior to the work happening. These breaches will be excavated to the original ground elevation and approximately 10 m wide at the waterline to allow for unencumbered water and aquatic movements during ice-cover periods. Excavated material will be placed on the toe portion of the adjacent dam structure slopes. Silt fencing will be installed downstream prior to conducting in water work to minimize silt loading downstream.

The concrete and corrugated materials comprising the outflow control structure will be removed and hauled to either the Sue C/A pit or the JEB TMF for disposal. Disturbed areas will be re-vegetated where necessary to prevent erosion and to minimize siltation into Vulture Lake.

Vulture/McClean Outflow Control Structure

The concrete portion of the Vulture Lake/McClean Lake outflow control structure will be fractured and left in-situ and covered with a minimum of 0.3 m of till. The control structure and discharge pipeline and diffuser that extends into McClean Lake, along with the weights holding them underwater, will be removed, the pipeline and diffuser cut into manageable lengths, and disposed of in either the Sue C/A pit or the JEB TMF. A 10-meter-wide spillway will be excavated to resemble the original outflow from Vulture Lake into McClean Lake.

Access Roads

Local access roads to the Sink/Vulture dam and control structures will be scarified and re-vegetated, where necessary.

5.3.8 Planning Envelope # 8: Ancillary Facilities and McClean Lake Mining Site

5.3.8.1 Description

The ancillary facilities planning envelope includes remaining areas and access roads associated with the McClean Lake Operation (Figure 7). The decommissioning financial summary for Planning Envelope #8 – Ancillary Facilities is provided as Table B2.9 of Appendix B.

The former Mining Equipment Development (MED) area, now referred to as the McClean Lake Mining site (Figure 8), is included in this decommissioning planning envelope. The mining method at the site is Surface Access Borehole Resource Extraction (SABRE) The financial estimate has been summarized separately and is included as Planning Envelope #8 – McClean Lake Mining Site, Table B2.10 of Appendix B.

5.3.8.2 Preliminary Decommissioning Approach

Access road ditches, trails, and other disturbed areas that have become overgrown with indigenous vegetation will be left as-is, if no re-grading of the area for drainage is required, as it would be counterproductive to re-disturb these areas.

Access Roads

Culverts along site access roads will be excavated, flattened, and deposited into an industrial landfill. Cross ditches will be installed at locations where culverts have been removed to allow natural flow pathways to be reestablished. Cross ditches will also be installed on steep gradients, where there is evident groundwater seepage as well as at road junctions.

Core Storage Areas

Given the valuable technical information associated with stored core samples, pursuant to the Mineral Tenure Registry Regulations and Saskatchewan Mineral Exploration Guidelines, it is desirable that existing core storage areas remain until such time as the responsible Ministry within the Province of Saskatchewan instructs otherwise. Nonetheless, costs have been included to decommission core associated with processed deposits (i.e. JEB, Sue A, Sue B, Sue C, and Sue E) and reclaim these areas where this core was stored. Core associated with other deposits not mined at the time of decommissioning is not considered part of the site decommissioning and will be left on site according to provincial regulation.

Both mineralized and barren core associated with processed deposits will be removed and processed through the McClean Lake Mill or disposed of in the Sue C/A pit, Sue C Contaminated Landfill or industrial landfill depending upon the timing of approval from the province to dispose of these materials.

Core shacks and wooden core racks will be burned under permit or otherwise demolished and disposed of in the Sue C/A pit, Sue C Contaminated Landfill or the JEB TMF. Noncombustible materials, including the perimeter fencing, will be disposed of in an industrial landfill, the Sue C/A pit, or the JEB TMF, as appropriate.

Disturbed areas will be scarified and re-vegetated, where necessary.

Explosives Storage and Manufacturing Sites

Due to cessation of open pit mining at the Sue site, the explosives storage area has been partially reclaimed. Storage buildings including the magazines and tanks were dismantled and removed from site by the explosive's vendor. At the time of final decommissioning, concrete pads will be fractured on a maximum 3 m grid and covered with a minimum of 0.3 m of clean till.

Moffatt Lake Area

Remaining wooden structures will be demolished and hauled to the Sue industrial landfill. Where wooden materials are uncontaminated, they may be burned, under permit, and subsequently disposed of. The materials in the former domestic landfill area will be covered by 2 m of till and the area re-contoured to establish stable slopes and resemble the surrounding topography. Disturbed areas will be scarified and re-vegetated, as necessary.

Security Gatehouse Area

The wooden building will be demolished and hauled to either the Sue industrial landfill or the Sue C/A pit along with the gate and fencing. The scale will be removed and disposed of in the Sue industrial landfill or the Sue C/A pit if it cannot be sold. The concrete portions of the scale will be fractured and covered with a minimum of 0.3 m of clean till.

Lines

The 115 kV overhead power line servicing the McClean Lake Operation will be removed by its owner, Saskatchewan Power Corporation (SaskPower) in accordance with the following SaskPower's Terms and Conditions:

4.15 Disconnection and Salvage

(a) Requests to Disconnect

Requests to disconnect Electrical Services may be made by the Customer associated with the Electrical Service.

(b) Salvage of SaskPower Facilities and/or Equipment

(i) Salvage of SaskPower Facilities and/or Equipment involves the physical removal of the SaskPower Facilities and/or Equipment installed to serve a Customer's Property. This may include SaskPower Facilities and/or Equipment located on and/or off the Customer's Property being served.

(ii) SaskPower may Salvage SaskPower Facilities and/or Equipment in whole or in part:

A. Immediately upon request by the Customer and authorization of the registered owner of the Property being served.

Electrical Facilities

Salvageable materials from these facilities will be sold. Unsaleable materials will be disposed of in the Sue C/A pit or the JEB TMF. Oil from transformers will be drained and shipped offsite for disposal or recycling. The power lines will be cut into manageable pieces and, along with power poles, disposed of in the Sue or JEB industrial landfill, the JEB TMF, or the Sue C/A pit.

The electrical distribution system located on the McClean Lake Mill terrace will be dismantled and non-contaminated materials will be salvaged and resold. Transformers will be drained of oils and the oils removed from site for disposal or recycling.

Pipelines & Associated Facilities

Pipelines will be flushed with clean water and blown out before removal. All water will be captured and directed for treatment at the JEB WTP or safely contained and transported off site for treatment. Unused pipelines will be disconnected, cut into manageable lengths, and disposed of in either the JEB TMF or Sue C/A pit.

Groundwater Monitoring Wells

There are currently 107 currently active groundwater monitoring wells at the McClean Lake Operation identified in the EMP (Orano 2023a). Active monitoring wells will be maintained in operational condition, where possible. Select wells will continue to be monitored throughout the post-operational, decommissioning, and post-closure periods, according to the evolving EMP for each phase, to verify decommissioning activities are effective and decommissioning objectives are met. Inactive wells, and wells not required after the operational period, will be decommissioned in accordance with Saskatchewan Ministry of Environment Guidelines for Northern Mine Decommissioning and Reclamation, 2008, which includes filling a portion of the well with bentonite or grout, cutting off the standpipe at or below grade, capping the cutoff pipe, and backfilling dug-out portion with clean fill.

McClean Mining Area

The McClean Mining site detail is provided in Figure 8. Contaminated materials in the sedimentation and clarification ponds, as well as the pond liners, will be removed and transported for disposal in the Sue C/A pit. Material under the liners will be checked for contamination and removed to the Sue C/A pit or covered with clean till to a sufficient depth to meet radiological criteria, where applicable. The decommissioning cost estimate (Table B2.10 of Appendix B) accounts for the excavation and removal of an additional 0.5 m depth of material below the lined mining pad and pond areas in the event underlying material is impacted. A higher contingency amount has been applied in the event additional reclamation is required.

Elevated berms will be levelled to blend the topography into the general surroundings and slopes will generally be maintained at less than 3H:1V. Concrete berms or pads will be fractured and hauled for disposal in the Sue C/A pit. The mining pad and the access road will be graded to remove the potential surface contamination and contaminated materials deposited into the Sue C/A pit. Following subsequent radiological surveys, residual contamination will be removed or covered with clean till to a depth sufficient to meet final radiological criteria. Culverts will be removed and replaced with cross ditches. Roadways will be scarified, and the disturbed area will be re-vegetated. Pipelines and electrical facilities will be decommissioned as described previously.

5.3.9 Planning Envelope # 9: Midwest Site

The Midwest Project received approval of the Environmental Impact Statement in 2012 (AREVA 2011). The project has not been developed. Upon a future development decision, the PDP will be revised to include further decommissioning detail and the financial cost estimate to update the financial assurance.

Decommissioning activities covered in this plan are based on the site as it currently exists, including areas disturbed as a result of the 1988 to 1989 test mine project. The Midwest Project is now included as part of the McClean Lake Operation and referred to herein as the Midwest site. The site is defined according to Orano's current surface lease for the Midwest site and the access road leading to the site from provincial highway #905, a small portion of which is outside the mineral leases.

The Midwest site planning envelope includes disturbed areas and remaining infrastructure from test mining at the Midwest site located approximately 15 km west of the McClean Lake Operation (Figure 9). The

decommissioning financial summary for Planning Envelope #9 – Midwest Site is provided as Table B2.11 of Appendix B.

5.3.9.1 Description

An underground exploration program was conducted at the Midwest site in 1988 which consisted of constructing a dam and dewatering a portion of Mink Arm of South McMahon Lake directly above the ore body and sinking a 185 m shaft and 170 m crosscut above the ore body for the test work. Currently, the Midwest site consists of a few inactive surface facilities constructed to support the underground test mining activities completed in 1989. These surface facilities include a water treatment plant, pump house, settling ponds, pipelines, steel and concrete control structure at the outlet of John Pond, shaft headframe, Mink Arm dam, former core storage area, groundwater monitoring wells, and associated access roads and trails.

5.3.9.2 Preliminary Decommissioning Approach

Water Treatment Plant

The water treatment plant decommissioning activities include dismantling the main building and associated equipment, and disposal of non-salvageable material at the McClean Lake Operation Sue C/A pit or JEB TMF. The concrete foundation and slab will be broken and buried in the uncontaminated water retention pond.

Pumphouse

The pumphouse is a small wood frame insulated structure with no salvage value. The pumphouse will be demolished and stockpiled for transport and disposal at the McClean Lake Operation Sue C/A pit or JEB TMF. The concrete foundation will be broken and buried in the uncontaminated water retention pond.

Lined Settling Ponds

Water from the settling ponds will be pumped into the mine shaft prior to capping of the shaft. The residual sludges, liner material from the settling ponds, and underlying contaminated soils (if identified) will be transported to for disposal in the Sue C/A pit or JEB TMF at the McClean Lake Operation. Slopes will be re-graded to less than 3H:1V and depressions backfilled to promote drainage.

Pipeline and Control Structure

Pipelines will be cut into manageable lengths. Although some of the pipelines may be salvageable, it is anticipated that pipelines will be disposed of at the Sue C/A pit or JEB TMF at the McClean Lake Operation. The steel and concrete control structure at the outlet of John Pond will be removed in conjunction with pipeline removal activities. All water will be captured and directed for treatment at the JEB WTP or contained and transported off site for treatment.

Headframe and Shaft

Decommissioning of the shaft area involves dismantling the wooden headframe and building covering the shaft opening, sealing the shaft with a concrete plug and cap, and general grading and contouring of the site. The shaft plug and cap will be designed and approved by a qualified professional engineer. Engineering work will also include long-term stability assessment of the shaft.

The former test mining area, including a pile of approximately 6,000 m³ of sandstone waste rock, will be graded and contoured to blend the site topography into the general surroundings (some natural slopes are steep) and to prevent ponding of water. Slopes will be generally maintained at less than 3H:1V.

Potential radiologically contaminated areas will be remediated by covering with local borrow material. Following decommissioning, the entire site will be subjected to a comprehensive radiological clearance survey to ensure that surficial radiation sources associated with previous operations meet final radiological criteria.

Mink Arm Dam

The decommissioning strategy for the dam takes best advantage of the current slope stability and existing indigenous vegetation established on the dam. Currently, the dam side slopes are stable and well vegetated with grasses and alder bushes. Removal of the entire dam would result in considerable siltation in the vicinity of the dam.

In 2019, an aging culvert within the dam was replaced with an armoured overflow weir. The armored channel maintains the same function of the former culvert that provided passive equalization of lake levels on either side of the Mink Arm dam.

It is therefore proposed that the dam be breached at two locations, near each shore, to provide adequate water circulation and opportunity for fish passage. The breaches will be excavated to the original lakebed depth and approximately 15 m wide at the waterline to allow for unencumbered water circulation and fish movement during the ice-cover period. The glacial till removed from the dam will be placed back from the shoreline to avoid siltation. Cobble/boulder material from the dam may be placed near the breached areas to create rocky points. These points could provide spawning and rearing habit for native fish species.

Core Storage Area

The drill core previously stored at the Midwest site has been relocated to the McClean Lake Operation core storage area at the Moffat site. In keeping with Mineral Tenure Registry Regulations and Saskatchewan Mineral Exploration Guidelines, decommissioning of core storage areas is not to be undertaken until such time as Orano is instructed to do so by the Minister responsible.

The perimeter fence will be removed and disposed of at the McClean Lake Operation and the area will be re-vegetated after satisfactory radiological survey results.

Groundwater Monitoring Wells

Select groundwater monitoring wells may continue to be monitored throughout the post-operational, decommissioning, and post-closure periods, according to the evolving EMP for each phase, to verify

decommissioning activities are effective and decommissioning objectives are met. Groundwater monitoring wells that are not required will be decommissioned in accordance with Saskatchewan Ministry of Environment Guidelines for Northern Mine Decommissioning and Reclamation, 2008 (EPB 381).

Access Roads

Most sections of road have neither grades nor ditches. Since test mining activities at the site, the roads have become partially overgrown with indigenous vegetation. Alders are well established outside the vehicle tracks and the centerline is now showing substantial growth as well. It would be counterproductive to now scarify these sections. It is proposed that only those sections with significant ditches or grades be re-contoured, scarified, and re-vegetated. Culverts will be removed, and natural flow patterns will be restored.

Re-vegetation

Re-vegetation will be conducted with the objective of returning the site to a condition which, as much as practical, emulates the pre-mining condition. Upon completion of decommissioning activities, disturbed areas will be re-vegetated. In several areas, natural invasion of alders and low ground-cover vegetation are currently well established. Where practical, these existing indigenous plants will be preserved.

5.3.10 Planning Envelope # 10: Sue F Mining Area

The proposed Sue F Project (former Caribou open pit mine) has been assessed and approved; however, similar to the Midwest Project, the development of the Sue F deposit has been postponed as of 2009. In previous versions of the PDP, a financial summary titled “Caribou Mining Area” was included which estimated the conceptual cost to decommission the proposed open pit and the associated waste rock pile, roads, and mining infrastructure. This summary has been removed from the current version, however, upon a future development decision; the PDP will be revised to again include the necessary decommissioning detail to update the financial assurance.

5.4 Post-Decommissioning and Institutional Control

5.4.1 Post-Decommissioning Monitoring

Following completion of the JEB TMF decommissioning and final demolition (WTP and on-site accommodations) it is expected that the site will conduct transitional environmental monitoring on a campaign basis. No on-going site security will be required. Transitional monitoring will continue until the site is transferred to provincial Institutional Control Program (ICP), to confirm decommissioning objectives and demonstrate that the site is safe (no unreasonable risk) for traditional land use.

The transitional phase monitoring program has not been developed or approved but is anticipated to last 10 years and to include:

- Monitoring of pore water chemistry to assess the concentration of various contaminants in the tailings pore water and
- Select groundwater monitoring wells and surface water in the vicinity and downstream of the JEB TMF.
- Continued monitoring of key downstream surface water receptor locations
- Third-party geotechnical inspections are also anticipated to be completed bi-annually.
- Final end state report that summarizes decommissioning activities.

5.4.2 Institutional Control program

Entry to ICP is anticipated to occur 20 years post-closure to allow for tailings consolidation and an additional period of time for transitional monitoring.

There are two funds and an assurance that are required under IC.

- 1 Monitoring and Maintenance Fund: *Reclaimed Industrial Sites Act* Section 11 and *Reclaimed Industrial Sites Regulations* Section 4 (1). The monitoring and maintenance fund is sufficient in that the initial value and interest generated cover the costs of monitoring and maintenance of the site for hundreds of years.
- 2 Unforeseen Events Fund: *Reclaimed Industrial Sites Act* Section 12 and *Reclaimed Industrial Sites Regulations* Section 4 (2). For a site with tailings, the unforeseen events fund is 20% of the monitoring and maintenance fund.
- 3 Financial Assurance: *Reclaimed Industrial Sites Regulations* Section 5. "...in an amount that is agreed to between the site holder and the minister and that reflects the costs of dealing with a maximum failure event that could occur at the closed site..." included as held as a letter of credit or other assurance instrument.

A cost estimate for application into IC is included in Table B2.20. A provision for ICP funding will be applied at the time of DDP development.

5.5 Sequencing of Decommissioning

5.5.1 Conceptual Decommissioning Schedule

Decommissioning the McClean Lake Operation will occur over a period of approximately 20 years which includes the following phases:

1. Post-Operational Phase – detailed work planning, licensing, permitting, and clean-up activities to prepare the facility for decommissioning.
2. Initial Decommissioning Phase – demolition of buildings/facilities that are not required for continued decommissioning and water treatment activities. Dewatering and capping of waste in the Sue C/A pit and final closure and reclamation of areas not needed during interim phase.
3. Interim Monitoring and Tailings Consolidation Phase – water treatment will be required for a period of approximately 10 years post-operations to achieve adequate consolidation of the tailings in the JEB TMF.
4. Final Decommissioning Phase – remaining site infrastructure will be demolished. A compacted till cover will be constructed over the consolidated tailings in the JEB TMF.
5. Post-Decommissioning or transitional Monitoring – environmental performance monitoring to ensure that the decommissioning objectives and success criteria have been met.
6. Application and acceptance into the provincial institutional control program
7. Long-term monitoring of the site, overseen by the provincial government paid for through company provided ICP funds (not included in schedule below).

The preliminary schedule below details the anticipated activities and timing of the decommissioning phases.

Area	Activity	Post-Operational		Initial Decommissioning		Interim Monitoring and Tailings Consolidation										Final Decommissioning	Post-Decommissioning Monitoring and application into ICP					
		Year	1	2	3	4	5	6	7	8	9	10	11	12	13	14	15	16	17	18	19	20
McClellan	Preparation for Decommissioning																					
JEB Area	Demolition and Reclamation (Initial)																					
	JEB WTP Operation																					
	JEB Area Demolition and Reclamation (Final)																					
Sue Area	Sue WTP Operation																					
	Sue Mining Area Closure																					
Monitoring	Routine Environmental Monitoring																					
	Interim Decommissioning Monitoring																					
	Post-Closure Environmental Monitoring																					
	Application into ICP																					

6 Financial Assurance Summary

The decommissioning cost estimate provided in this updated Preliminary Decommissioning Plan & Financial Assurance document is \$122,558,000 (CAD). This represents an increase of approximately \$20.5M from the currently held financial assurance of \$102,098,000 (CAD).

This preliminary decommissioning cost estimate differs from Version 9 due to the following changes:

1. The plan has been revised using current rates for materials, equipment, and labour for decommissioning cost development. Unit rate costs have increased approximately 9% overall.
2. JEB TMF Expansion includes cover and landform design, approximately \$56M for a total TMF decommissioning estimate increase of approximately \$35M.
3. Discounting the final cost estimate to year zero.

Financial Instruments are provided in Appendix D.

The following table summarizes the planning envelopes and indirect cost estimates for the updated Financial Assurance:

Table B2.1		
Preliminary Decommissioning Plan Cost Summary		
<i>Version 10</i>		
B1.1	Post-Operational Period	\$12,155,180
B2.2	PE#1: JEB Mining Area	\$1,724,580
B2.3	PE#2: McClean Lake Mill and Associated Facilities	\$10,428,012
B2.4	PE#3: JEB TMF	\$55,884,047
B2.5	PE#4: Permanent Camp Area	\$620,849
B2.6	PE#5: Sue Mining Area	\$10,005,504
B2.7	PE#6: Sue Site and Associated Facilities	\$558,783
B2.8	PE#7: Sink/Vulture TEMS	\$160,272
B2.9	PE#8i: Ancillary Facilities	\$2,377,476
B2.10	PE#8ii: McClean Lake Mining Site	\$232,867
B2.11	PE#9: Midwest Site ¹	\$251,704
B2.17	Camp & Operational Costs	\$16,216,960
B2.18	Project Management	\$10,107,625
B2.19	Interim Monitoring	\$7,582,789
B2.20	Post-Closure Monitoring	\$9,392,642
Subtotal²		\$137,700,000
Discounting to Year Zero		\$111,003,994
Inflation for 5 Year Planning Period		\$11,553,385
Total		\$122,558,000

¹ Midwest Site future decommissioning costs will be included in financial assurance upon a project development decision.

² The Sue F Project decommissioning costs will be included in financial assurance upon a project development decision.

7 Progressive Reclamation and Decommissioning

Advancement of closure activities during the construction and operations phases when progressive reclamation and decommissioning opportunities arise are preferred. Efforts during construction include stockpiling of topsoil and water diversion as described in the planning envelope descriptions. Progressive reclamation and decommissioning efforts to advance closure during operations are summarized in Section 7.1 and 7.2 below, while progressive decommissioning intended to meet final closure success criteria are detailed in Section 7.3.

7.1 Progressive Reclamation Activities

Examples of progressive reclamation activities that have been completed at the McClean Lake Operation include:

- general site clean-up activities at the Midwest site between 1997 and 2000;
- placing problematic waste rock from open pit mining into open pits, as available, capping with a till cover and allowing pits to flood;
- contouring of clean waste rock stockpiles; and,
- re-vegetation on the JEB and Sue C/A clean waste rock piles.

The preferred strategy for the Sue Mining Area is to progressively reclaim areas during the operational period. This has been demonstrated over the last several years upon completion of active mining in 2008 with partial re-contouring of clean waste rock stockpiles and removal of temporary structures such as modular trailers and pipelines. Orano will work with the Province of Saskatchewan to have the parcels be deemed decommissioned and potentially re-classified as undeveloped under the Provincial surface lease.

7.2 Progressive Decommissioning Activities

Examples of progressive decommissioning activities that have been completed at McClean Lake Operation include:

- JEB clean waste rock pile - Approximately three of four sides of the current stockpile are currently re-contoured and partially re-vegetated.
- Special waste from open-pit mining at the McClean Lake Operation has been disposed of into available open pits as part of progressive reclamation efforts. The Sue C/A pit is the current repository for special waste generated during the mining of the JEB, Sue C, Sue A, Sue E open pits and McClean mining drill cuttings; Sue C/A is the proposed future repository of potentially reactive waste rock (PRWR) generated from Cameco Corporation's Cigar Lake mine and the future mining of the Sue F ore bodies. Sue E is the

repository for special waste rock mined from the Sue B pit (which was also capped). Sub-aqueous disposal of problematic waste rock materials is a best practice in mine waste management (INAP 2010).

- Previously, hydraulic containment of the JEB TMF was controlled through a combination of pumping from a perimeter ring of dewatering wells, water reclaim pumping from the JEB TMF pond and the base drain. The purpose of the dewatering wells was to intercept and divert clean groundwater entering the JEB TMF to reduce the amount of water requiring treatment, and to control water levels within the JEB TMF. The dewatering well infrastructure has been decommissioned since 2017 to allow for the optimization and expansion of the JEB TMF. Only three dewatering wells remain to be decommissioned along with miscellaneous piping and electrical cables.

7.3 Progressive Decommissioning that Achieves Final Closure Criteria

Construction reports, as-built drawings and regulatory correspondence can be found in Appendix H for works that have been decommissioned.

Decommissioning works at the McClean Lake Operation that meet final closure criteria include:

- **Temporary Contaminated Materials Landfill**

A former landfill for contaminated material was located adjacent to the JEB TMF. The landfill required decommissioning to make way for the JEB TMF expansion activity. The waste was removed and transported for permanent disposal in the Sue C/A Pit in 2017

- **Mining Sedimentation Ponds**

Three former sedimentation ponds used during mining of the JEB pit were progressively decommissioned in 2016 to make way for construction of the JEB PMP Pond (Section 5.3.1.2). The single layer HDPE liner was cut into manageable pieces and transported to the temporary contaminated materials landfill. Material under the liner was assessed for radiological and environmental contamination. Approximately 179 m³ of contaminated soil from the sedimentation ponds was removed and disposed of in the Sue C/A pit. No further decommissioning is required so no funds are allocated in this version of the PDP, and the ponds will be removed from this package in future iterations.

Progressive decommissioning works in the Sue area are likely to prioritize transition of the Sue B and Sue E mined-out pits to decommissioned pit lakes and transition of the Sue C waste rock pile into a decommissioned and reclaimed structure with an overall goal of shifting towards passive management (e.g. equilibriums) and reducing overall water treatment and management while protecting the environment.

8 References

- AREVA. 2011a. Midwest Project Environmental Impact Statement. September.
- AREVA. 2011b. McClean Lake Operation Hydrogeology and Groundwater Modelling of the Collins Creek Basin Technical Information Document. Volume 1. Version 2. December.
- AREVA. 2013. Waste Rock Technical Information Document. June 2013.
- AREVA. 2016a. McClean Lake Operation. Public Information Program. Version 1. Revision 2 December 2016.
- AREVA Resources Canada Inc. (AREVA). 2017. McClean Lake Operation Technical Information Document, Environmental Performance, Volume 2 of 2 - Environmental Risk Assessment. Version 3, Revision 1, September.
- Associated Environmental (AE). 2017. Contaminated Landfill Relocation. December.
- Canadian Council of Ministers of the Environment (CCME). Canadian Environmental Quality Guidelines.
- CNSC. 2018a. REGDOC 2.11.1 Waste Management, Volume II: Management of Uranium Mine Waste Rock and Mill Tailings. November.
- CNSC. 2018b. REGDOC 3.2.1. Public and Aboriginal Engagement: Public Information and Disclosure. May.
- CNSC. 2020. REGDOC 2.9.1, Environmental Protection: Environmental Principles, Assessments and Protection Measures, V 1.2. September.
- CNSC. 2021a. REGDOC 2.11.1 Waste Management, Volume I: Management of Radioactive Waste. January.
- CNSC. 2021b. REGDOC 2.11.1 Waste Management, Volume III: Safety Case for the Disposal of Radioactive Waste. Version 2 January.
- CNSC. 2021c. REGDOC 2.11.2 Waste Management: Decommissioning. January.
- CNSC. 2021d. REGDOC 3.3.1. Financial Guarantees for Decommissioning of Nuclear Facilities and Termination of Licenced Activities. January.
- CNSC. 2022. REGDOC 3.2.2. Public and Indigenous Engagement: Indigenous Engagement. V1.2 February.
- CNSC. 2024. Licence Conditions Handbook, LCH-MINEMILL-McCLEAN.02/2027, McClean Lake Operation, Uranium Mine Operating Licence, UML-MINEMILL-McCLEAN.02/2027. May. Ottawa, Ontario.
- Canadian Standards Association, (CSA). 2019. Decommissioning of Facilities Containing Nuclear Substances. N294-19.

- COGEMA Resources Inc. (COGEMA). 2004d. McClean Lake Operation. Sue E EIS.
- Golder Associates Ltd. (Golder) 2011a. Closure Landform Design for the JEB TMF and Waste Rock Pile. April.
- Golder Associates Ltd. (Golder) 2011b. Soil Cover Design. July.
- Golder Associates Ltd. (Golder) 2017. Record of Construction – Temporary Contaminated Landfill Relocation. December.
- Golder Associates Ltd. (Golder). 2019. Record of Construction – JEB TMF Optimization Stage 2. 2018 Construction.
- Golder Associates Ltd. (Golder). 2021. Record of Construction – McClean Lake JEB TMF 457.5 m ASL Embankment. 2021 Construction. December.
- IAEA. 2010. Best Practice in Environmental Management of Uranium Mining. IAEA Nuclear Energy Series No. NF-T-1.2.
- IAEA. 2011. Disposal of Radioactive Waste, Specific Safety Requirements No. SSR-5. Vienna. April. IAEA. 2012. The Safety Case and Safety Assessment for the Disposal of Radioactive Waste, Specific Safety Guide No. SSG-23. Vienna. September.
- International Council on Mining and Metals (ICMM). 2019a. Integrated Mine Closure. Good Practice Guide, 2nd Edition. February.
- International Council on Mining and Metals (ICMM). 2019b. Financial Concepts for Mine Closure.
- International Council on Mining and Metals (ICMM). 2020. Global Industry Standard on Tailings Management. August.
- International Council on Mining and Metals (ICMM). 2022. Closure Maturity Framework. January.
- International Network for Acid Prevention (INAP). 2010. Global Acid Rock Drainage Guide. December.
- Minatco Ltd. 1991. McClean Lake Project Environmental Impact Statement. August.
- Orano Canada (Orano). 2019a. Cluff Lake Project – Detailed Post Decommissioning Plan V4R1. March 2019
- Orano Canada (Orano). 2019b. JEB TMF Expansion (486 mASL) – Project Description. Version 3. October 2019
- Orano Canada (Orano). 2022. McClean Lake Operation - Facility Description Manual. Version 6. March 2022
- Orano Canada (Orano). 2023a. McClean Lake Operation - Environmental Monitoring Program Design Document. Version 4. December 2023

- Orano Canada (Orano). 2023b. McClean Lake Operation - Environmental Monitoring Program Locations, Frequencies and Parameters. Version 11. December 2023
- Orano Canada (Orano). 2023c. McClean Lake Operation - Environmental Protection Code of Practice, Version 4. November 2023
- Orano Canada (Orano). 2023d. McClean Lake Operation Waste Rock Management Technical Information Document, Part A: Summary of Current Waste Rock Management Practice. Version 3 Revision 1. January 2023
- Orano Canada (Orano). 2024. Emergency Response Assistance Plan. Version 5. August 2024
- Orano Canada (Orano). 2025a. McClean Lake Operation Environmental Performance Technical Information Document. Volume 1 of 2 – Environmental Performance Assessment. Version 1 Revision 0. December 2025
- Orano Canada (Orano). 2025b. McClean Lake Operation Environmental Performance Technical Information Document. Volume 2 of 2 – Environmental Risk Assessment. Version 1 Revision 0. December 2025
- Orano Canada (Orano). 2025c. McClean Lake Operation. Integrated Management System. Version 10. March 2025
- Orano Canada (Orano). 2025d. McClean Lake Operation. Public Information Program. Version 3. April 2025.
- Orano Canada (Orano). 2025e. McClean Lake Operation Tailings Management Technical Information Document. Version 04, Revision 00. December 2025
- Organization for Economic Cooperation and Development. Nuclear Energy Agency (OECD-NEA). 2014. Managing Environmental and Health Impacts of Uranium Mining.
- The Occupational Health and Safety Regulations, 2020. Saskatchewan Ministry of Environment (SMOE). 1996.
- The Mineral Industry Environmental Protection Regulations, 1996. Chapter E-10.2 Reg 7. March 06.
- SMOE. 2021. Landfill Decommissioning and Reclamation (Closure) Guidance, December 2021
- SMOE. 2003. Reclamation Guidelines for Sand and Gravel Operators. May. SMOE. 2008. EPB 381 SMOE. Guidelines for Northern Mine Decommissioning and Reclamation, November. Version 6.
- Statistics Canada. 2024. Consumer Price Index, monthly, not seasonally adjusted. Table 18-10-0004-01. <https://www150.statcan.gc.ca/t1/tbl1/en/cv.action?pid=1810000401#timeframe>
- WSP Canada Inc. (WSP) 2023. Record of Construction - 2023 McClean Lake JEB TMF 452.5 m ASL Soil-Bentonite Liner. December.

Appendix A Figures

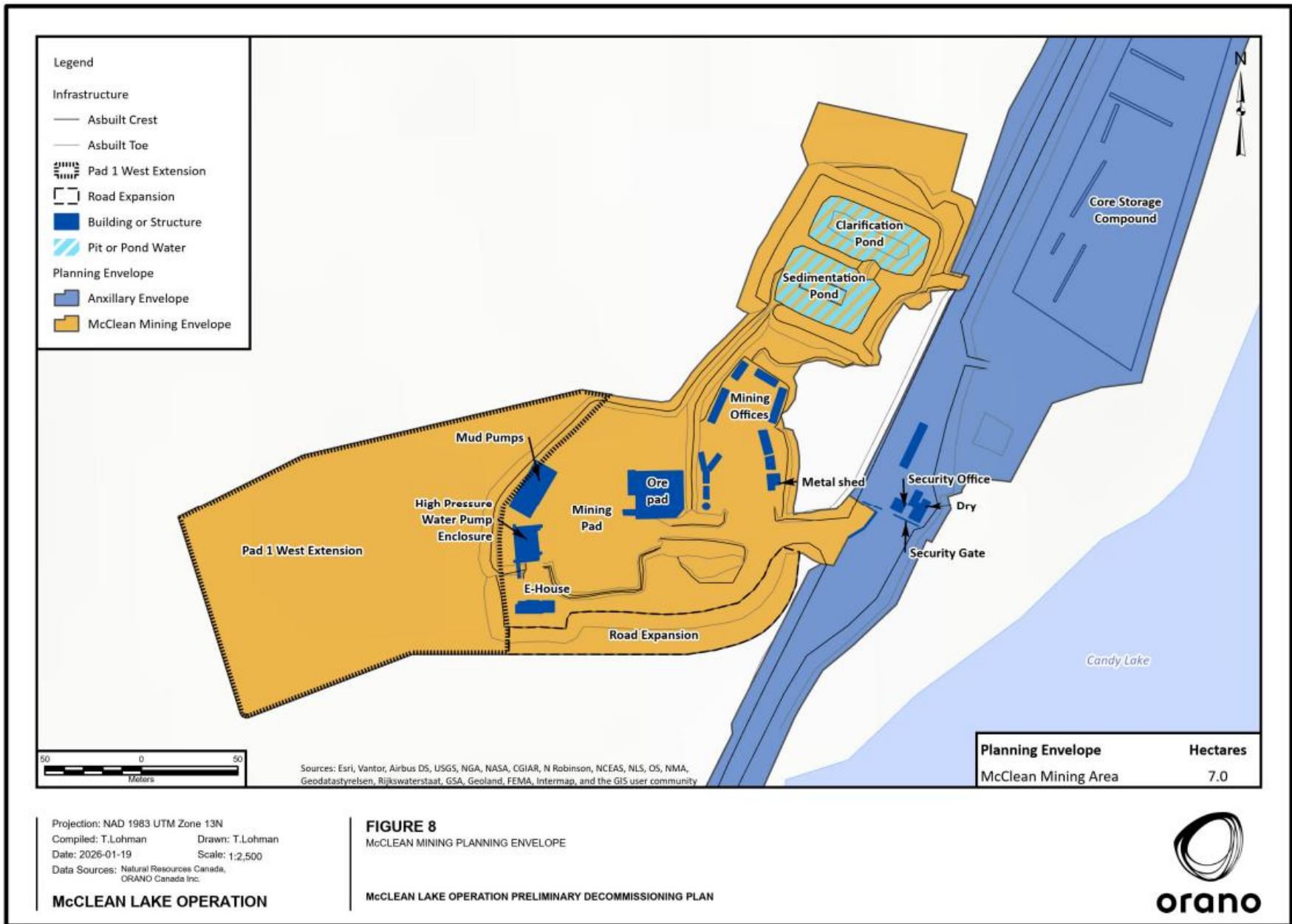

File: Q:\SHEQ\GIS\McCLELLAN_LAKE\2024\PDPI\PDPAprx

Appendix B Financial Calculations

Table B1.1	
Post-Operational Period Cost Summary	
<i>Version 10</i>	
B1.2 Water Treatment	\$ 5,398,127
B1.3 Hazardous Materials Cleanup	\$ 392,024
B1.4 Project Management	\$ 1,771,000
B1.5 Operating Costs	\$ 1,047,032
B1.6 Security	\$ 376,728
B1.7 Flights	\$ 286,000
B1.8 Environmental Monitoring	\$ 942,201
B1.9 Fees	\$ 1,942,069
Total	\$ 12,155,180

**Table B1.2
Post-Operational - Water Treatment**

JEB Water Treatment Plant Operation

Cost estimate is based on operating the JEB WTP on an intermittent basis for the two year post-operational period in order to maintain hydraulic containment. It is anticipated that consolidation of tailings will achieve endpoint criteria in approximately 10 years after the waste rock surcharge is placed during the initial decommissioning period.

			<i>Years of Treatment</i>	<i>Months per year</i>	<i>Cost per m³</i>	<i>Rate (m³/day)</i>	<i>Cost</i>
JEB WTP			2	12	\$ 2.00	810	\$ 1,167,031

Sue Water Treatment Plant Operation

Cost estimate is based on operating the Sue WTP on a continuous basis for the two year post-operational period. It is anticipated that the pit water can be drawn down to construct the special waste cover after 3 additional years of continuous water treatment.

			<i>Years of Treatment</i>	<i>Months per year</i>	<i>Cost per m³</i>	<i>Rate (m³/day)</i>	<i>Cost</i>
Sue WTP			2	12	\$ 1.68	3,500	\$ 4,231,095

Water treatment unit cost is inclusive of all operational and manpower costs.

Total Water Treatment Cost for Post-Operational Period	\$ 5,398,127
---	---------------------

**Table B1.3
Post-Operational - Hazardous Materials Cleanup**

Ore and waste pad areas to be cleared off to minimize contamination of surface runoff requiring treatment. Materials will be transported and disposed of in either the JEB TMF or Sue C/A pit.

Ore Pad (JEB Area)					
	<i>Ore Pad</i>		<i>Cost</i>	<i>Hours</i>	
	<i>Area (m²)</i>	<i>Qty</i>	<i>per hour</i>	<i>required</i>	<i>Cost</i>
Grader 14H	45,237	1	\$ 304.00	11	\$ 3,438
Bulldozer D8N		1	\$ 345.00	75	\$ 26,011
Front End Loader 992D		1	\$ 626.00	55	\$ 34,430
Rock truck - 100 ton		2	\$ 468.00	55	\$ 51,480
				Subtotal	\$ 115,359
Ore Transfer Pad (Sue Mining Area)					
	<i>Ore Pad</i>		<i>Cost</i>	<i>Hours</i>	
	<i>Area (m²)</i>	<i>Qty</i>	<i>per hour</i>	<i>required</i>	<i>Cost</i>
Grader 14H	57,187	1	\$ 304.00	14	\$ 4,346
Bulldozer D8N		1	\$ 345.00	95	\$ 32,883
Front End Loader 992D		1	\$ 626.00	65	\$ 40,690
Rock truck - 100 ton		2	\$ 468.00	65	\$ 60,840
				Subtotal	\$ 138,759
McClellan Mining Site Ore Pad					
	<i>Ore Pad</i>		<i>Cost</i>	<i>Hours</i>	
	<i>Area (m²)</i>	<i>Qty</i>	<i>per hour</i>	<i>required</i>	<i>Cost</i>
Front End Loader 988F	615	1	\$ 284.00	3	\$ 852
Rock Truck - 40 ton		2	\$ 332.00	3	\$ 1,992
				Subtotal	\$ 2,844
Hazardous Waste Materials Disposal					
<i>Inventory of hazardous materials stored on-site at any point in time results in the following costs to ship materials offsite to another operating mine, the supplier, or licensed recycling/disposal facility.</i>					
		<i>Inventory</i>		<i>Disposal</i>	<i>Cost</i>
		<i>Qty</i>	<i>(m³)</i>	<i>Cost (\$/m³)</i>	
Nuclear Gauges		13		lump	\$ 20,000
HAZMAT Pad Materials and Waste Oil			51	\$ 191.67	\$ 9,775
Bulk Reagents Transported Offsite ¹			643	\$ 121.67	\$ 78,275
25% Contingency ²					\$ 27,012
				Subtotal	\$ 135,062
Total Hazardous Materials Cleanup Cost for Post-Operational Period					\$ 392,024

¹ Bulk reagents includes unused reagent inventory and residual amounts cleaned from mill circuits that cannot be disposed of onsite. Disposal options include transport to other mining operations or return to vendors. Some reagents will continue to be utilized during the decommissioning period for water treatment operations.

² A 25% contingency amount is applied to account for variability in onsite inventory.

**Table B1.4
Post-Operational - Project Management**

Project Staff	Qty	Time per Year	Annual Cost	Period (years)	Annual Wages		Cost
					Year 1	Year 2	
Project Manager	1	0.5	\$ 204,000	2	\$ 102,000	\$ 102,000	\$ 204,000
Environment/Safety Coordinator	1	0.5	\$ 124,000	2	\$ 62,000	\$ 62,000	\$ 124,000
Environment/Safety Technician	2	0.5	\$ 83,000	2	\$ 83,000	\$ 83,000	\$ 166,000
Radiation Technician	2	0.5	\$ 70,000	2	\$ 70,000	\$ 70,000	\$ 140,000
Engineering Technician	1	0.5	\$ 97,000	2	\$ 48,500	\$ 48,500	\$ 97,000
Electrician	2	0.5	\$ 110,000	2	\$ 110,000	\$ 110,000	\$ 220,000
Mechanic	2	0.5	\$ 110,000	2	\$ 110,000	\$ 110,000	\$ 220,000
Administrative Supervisor	1	0.5	\$ 110,000	2	\$ 55,000	\$ 55,000	\$ 110,000
Accounting Technician	1	0.5	\$ 70,000	2	\$ 35,000	\$ 35,000	\$ 70,000
General Labourer	6	0.5	\$ 70,000	2	\$ 210,000	\$ 210,000	\$ 420,000
Water Treatment Plant Operator	6	0.5	<i>Included in water treatment operational cost calculations</i>				
Total Project Management Cost for Post-Operational Period							\$ 1,771,000

**Table B1.5
Post-Operational - Operating Costs**

Generator Fuel

Generators will be required to power JEB and Sue WTPs as well as to provide heat and electricity for general site facilities in use.

		Consumption	Run time	Cost per	
	Years	(L/hr)	(hrs/day)	litre	Cost
Post-Operational Period	2	20	24	\$ 1.35	\$ 473,000

Freight and General Supplies

Allowance for transport of required equipment on site other than those covered in mob/demob costs of contractors.

Freight			Trips	Unit Cost	
	Years		per season	per trip	Cost
Post-Operational Period	2		21	\$ 4,300	\$ 180,600

General Supplies and Equipment

Allowance for site communications and office supplies

				Cost	
			Years	per year	Cost
Post-Operational Period			2	\$ 25,000	\$ 50,000

Temporary Camp

Crews will reside either onsite or at Points North, a distribution outpost, located approximately 15 km from the McClean Lake Operation.

			Cost per	Time	
	Years	Personnel	person/day	per year	Cost
Field Staff	2	14	\$ 80	0.42	\$ 343,392
WTP Operators and Security	2	3	\$ 80	1	\$ 175,200

Total Operating Cost for Post-Operational Period	\$ 1,047,032
---	---------------------

**Table B1.6
Post-Operational - Security**

Allowance for continuous site security presence for two year post-operational period				
			<i>Unit Cost</i>	
	<i>Personnel</i>	<i>Years</i>	<i>per year</i>	<i>Cost</i>
Security	2	2	\$94,182	\$ 376,728
Total Security Cost for Post-Operational Period				\$ 376,728

**Table B1.7
Post-Operational - Flights**

Assumes personnel will work on a two-week in / two-week out rotational basis. Based on 27 employees - 13 and 14 per shift. Year-round crew includes flights for water treatment plant operators and security staff with a continuous site presence.

		<i>Field</i>	<i>Trips</i>	<i>Unit Cost</i>	
	<i>Aircraft</i>	<i>seasons</i>	<i>per season</i>	<i>per flight</i>	<i>Cost</i>
Seasonal Field Crew	Beechcraft 1900	2	13	\$ 11,000	\$ 286,000
Year-round Staff	King Air 200	2	26	\$ 6,500	\$ 338,200
Total Flight Cost for Post-Operational Period					\$ 286,000

Table B1.8

Allowance for environmental studies and monitoring programs during the two year post-operational period.

Item	Quantity	Units	Period (years)	Unit Cost		Cost
Environmental Lab Analyses	400	<i>per yr</i>	2	\$ 750	<i>ea</i>	\$ 600,000
Environmental Effects Monitoring Studies	1	<i>ea</i>	1	\$ 212,258	<i>lump</i>	\$ 212,258
Geotechnical Inspections (e.g. Slope stability, general site erosion, dams)	1	<i>per yr</i>	2	\$ 22,082	<i>per yr</i>	\$ 44,163
General Site Maintenance	1	<i>ea</i>	1	\$ 85,779	<i>per yr</i>	\$ 85,779
Total Environmental Monitoring Cost for Post-Operational Period						\$ 942,201

**Table B1.9
Post-Operational - Fees**

<i>Item</i>	<i>Quantity</i>	<i>Years</i>	<i>Unit Cost</i>		<i>Cost</i>
CNSC Fees ¹	1	2.0	\$438,034	per yr	\$ 876,069
Regulatory Process and Engagement Fees ²	1	2.0	\$533,000	per yr	\$1,066,000
Total Fees for Post-Operational Period					\$ 1,942,069

¹ CNSC fees include applicable license fees and regulatory oversight.

² Regulatory process fees include applicable legal fees and permit costs.

Table B2.1		
Preliminary Decommissioning Plan Cost Summary		
<i>Version 10</i>		
B1.1	Post-Operational Period	\$12,155,180
B2.2	PE#1: JEB Mining Area	\$1,724,580
B2.3	PE#2: McClean Lake Mill and Associated Facilities	\$10,428,012
B2.4	PE#3: JEB TMF	\$55,884,047
B2.5	PE#4: Permanent Camp Area	\$620,849
B2.6	PE#5: Sue Mining Area	\$10,005,504
B2.7	PE#6: Sue Site and Associated Facilities	\$558,783
B2.8	PE#7: Sink/Vulture TEMS	\$160,272
B2.9	PE#8i: Ancillary Facilities	\$2,377,476
B2.10	PE#8ii: McClean Mining Site	\$232,867
B2.11	PE#9: Midwest Site ¹	\$251,704
B2.17	Camp & Operational Costs	\$16,216,960
B2.18	Project Management	\$10,107,625
B2.19	Interim Monitoring	\$7,582,789
B2.20	Post-Closure Monitoring	\$9,392,642
Subtotal²		\$137,700,000
Discounting to Year Zero		\$111,003,994
Inflation for 5 Year Planning Period		\$11,553,385
Total		\$122,558,000

¹ Midwest Site future decommissioning costs will be included in financial assurance upon a project development decision

² The Sue F Project decommissioning costs will be included in financial assurance upon a project development decision

**Table B2.2
Planning Envelope #1 - JEB Mining Area**

Building Demolition & Removal				
	<i>Qty</i>	<i>Hourly rate</i>	<i>Hours required</i>	<i>Cost</i>
CAT Hydraulic Excavator 345C	1	\$ 329.00	12	\$ 3,948
CAT Dozer D8N w/ ripper	1	\$ 345.00	12	\$ 4,140
CAT Front End Loader 992D	1	\$ 626.00	7	\$ 4,378
Rock Truck - 40 ton	4	\$ 332.00	7	\$ 9,287
Flat Deck with 12 ton crane	1	\$ 180.00	40	\$ 7,200
Vacuum Truck	1	\$ 401.00	3	\$ 1,203
General Labourer	2	\$ 65.00	40	\$ 5,200
Concrete Fracturing				
	<i>Area</i>	<i>Cost</i>		
	<i>m²</i>	<i>per m²</i>		<i>Cost</i>
	1,267	\$ 33.00		\$ 41,807
Till Cover Over Concrete				
	<i>Qty</i>	<i>Hourly rate</i>	<i>Hours required</i>	<i>Cost</i>
CAT Front End Loader 988F	1	\$ 284.00	6	\$ 1,704
Rock Truck - 40 ton	2	\$ 332.00	6	\$ 3,984
CAT Dozer D6T w/ ripper	1	\$ 291.00	3	\$ 873
Waste Rock Stockpile Recontouring				
	<i>Qty</i>	<i>Hourly rate</i>	<i>Hours required</i>	<i>Cost</i>
CAT Grader 14H w/ scarifier	1	\$ 304.00	9	\$ 2,763
CAT Dozer D8N w/ ripper	1	\$ 345.00	334	\$ 115,144
Culvert Removal & Cross Ditching				
	<i>Qty</i>	<i>Hourly rate</i>	<i>Hours required</i>	<i>Cost</i>
CAT Hydraulic Excavator 345C	1	\$ 329.00	35	\$ 11,515
Flat Deck with 12 ton crane	1	\$ 180.00	35	\$ 6,300
Road & Area Scarification				
	<i>Qty</i>	<i>Hourly rate</i>	<i>Hours required</i>	<i>Cost</i>
CAT Grader 14H w/ scarifier	1	\$ 304.00	130	\$ 39,578
CAT Dozer D6T w/ ripper	1	\$ 291.00	167	\$ 48,500
Ponds, Pipelines, Utilities				
	<i>Qty</i>	<i>Hourly rate</i>	<i>Hours required</i>	<i>Cost</i>
Crawler Crane - 50 ton	1	\$ 256.00	100	\$ 25,600
CAT Dozer D8N w/ ripper	1	\$ 345.00	70	\$ 24,150

Table B2.2 Planning Envelope #1 - JEB Mining Area				
CAT Front End Loader 992D	1	\$ 626.00	280	\$ 175,280
Rock Truck - 100 ton	2	\$ 468.00	280	\$ 262,080
CAT Front End Loader 988F	1	\$ 284.00	70	\$ 19,880
Rock Truck - 40 ton	2	\$ 332.00	70	\$ 46,480
Flat Deck with 12 ton crane	1	\$ 180.00	140	\$ 25,200
General Labourer	2	\$ 65.00	300	\$ 39,000
Ore Pad				
		<i>Hourly</i>	<i>Hours</i>	
	<i>Qty</i>	<i>rate</i>	<i>required</i>	<i>Cost</i>
CAT Grader 14H w/ scarifier	1	\$ 304.00	5	\$ 1,402
CAT Dozer D8N w/ ripper	1	\$ 345.00	94	\$ 32,451
CAT Front End Loader 992D	1	\$ 626.00	105	\$ 65,425
Rock Truck - 100 ton	4	\$ 468.00	105	\$ 195,648
Revegetation				
		<i>Cost</i>	<i>Area</i>	
		<i>per ha</i>	<i>(ha)</i>	<i>Cost</i>
Grass		\$ 5,449.36	14.0	\$ 76,291
Trees		\$ 4,064.50	50.0	\$ 203,225
Subtotal				\$ 1,499,635
Contingency			15.0%	\$224,945
Total Decommissioning Estimate				\$ 1,724,580

Table B2.3				
Planning Envelope #2 - McClean Mill and Associated Facilities				
Building Demolition & Removal ¹	Area	Cost		
Includes mill complex demolition	<i>m²</i>	<i>per m²</i>		<i>Cost</i>
and concrete fracturing	29,131	\$ 294.27		\$ 8,572,396
Till Cover Over Concrete		<i>Hourly</i>	<i>Hours</i>	
	<i>Qty</i>	<i>rate</i>	<i>required</i>	<i>Cost</i>
CAT Front End Loader 988F	1	\$ 284.00	33	\$ 9,372
Rock Truck - 40 ton	2	\$ 332.00	33	\$ 21,912
CAT Dozer D6T w/ ripper	1	\$ 291.00	25	\$ 7,275
Culvert Removal & Cross Ditching		<i>Hourly</i>	<i>Hours</i>	
	<i>Qty</i>	<i>rate</i>	<i>required</i>	<i>Cost</i>
CAT Hydraulic Excavator 345C	2	\$ 329.00	27	\$ 17,766
Flat Deck with 12 ton crane	2	\$ 180.00	27	\$ 9,720
Road & Area Scarification		<i>Hourly</i>	<i>Hours</i>	
	<i>Qty</i>	<i>rate</i>	<i>required</i>	<i>Cost</i>
CAT Grader 14H w/ scarifier	1	\$ 304.00	17	\$ 5,262
CAT Dozer D6T w/ ripper	1	\$ 291.00	50	\$ 14,550
Ponds, Pipelines, Utilities		<i>Hourly</i>	<i>Hours</i>	
	<i>Qty</i>	<i>rate</i>	<i>required</i>	<i>Cost</i>
Crawler Crane - 50 ton	1	\$ 256.00	80	\$ 20,480
CAT Dozer D8N w/ ripper	1	\$ 345.00	50	\$ 17,250
CAT Front End Loader 992D	1	\$ 626.00	70	\$ 43,820
Rock Truck - 100 ton	2	\$ 468.00	70	\$ 65,520
CAT Front End Loader 988F	1	\$ 284.00	30	\$ 8,520
Rock Truck - 40 ton	2	\$ 332.00	30	\$ 19,920
Flat Deck with 12 ton crane	1	\$ 180.00	300	\$ 54,000
General Labourer	2	\$ 65.00	300	\$ 39,000
Revegetation		<i>Cost</i>	<i>Area</i>	
		<i>per Ha</i>	<i>(ha)</i>	<i>Cost</i>
Grass		\$ 5,449.36	14.7	\$ 80,106
Trees		\$ 4,064.50	15.0	\$ 60,968
Subtotal				\$ 9,067,837
Contingency			15.0%	\$ 1,348,533
Total Decommissioning Estimate				\$ 10,428,012

¹ Mill demolition rate is inclusive of removal of interior equipment and piping, exterior cladding, structure

Table B2.4
Planning Envelope #3 - JEB Tailings Management Facility (TMF)

The anticipated surface elevation of tailings in the JEB TMF in 2030 is approximately 447 mASL. A 2 m layer of sand and 2 m layer of drain rock filter will be placed on top of the tailings. This will be followed by a 1 m layer of waste rock, a m layer of sand, a 1 m barrier layer and a 1.5 m surface layer. Hauling distance for cover material has been considered in the unit rate pricing for cover material. The barrier does not extend down the embankment slopes as the embankment liner provides as a barrier.

TMF Cover	<i>Qty</i>	<i>Units</i>	<i>Unit Cost</i>	<i>Cost</i>
Mobilization	2	ea	\$300,000	\$600,000
Regrading slopes	400,000	m ³	\$10.21	\$4,085,099
2 m of sand to 449 mASL	280,000	m ³	\$10.21	\$2,859,569
2 m of rock to 451 mASL	298,000	m ³	\$10.21	\$3,043,399
1 m of waste rock to 452 mASL	153,000	m ³	\$10.21	\$1,562,550
1 m of filter material to 453 mASL	158,000	m ³	\$10.21	\$1,613,614
1 m of soil bentonite barrier material to 454 mASL	162,000	m ³	\$75.50	\$12,231,000
1.5 m of surface finish material to 455.5 mASL	52,232	m ³	\$10.21	\$533,432
Bentonite for barrier layer	22,680,000	kg	\$0.695	\$15,762,600
Contaminated Materials Hauling	<i>Haul Distance</i>	<i>Backfill Volume</i>	<i>Unit Haul Cost</i>	
<i>Infrastructure demolition debris based on rubble volumes</i>	<i>(km)</i>	<i>(m³)</i>	<i>(\$/ m³per km)</i>	<i>Cost</i>
	1.2	3,848	\$ 15.11	\$ 70,660
TMF Water Treatment	<i>Years of Treatment</i>	<i>Cost per m³</i>	<i>Rate (m³/day)</i>	<i>Cost</i>
<i>Tailings Porewater Treatment</i>				
Water Treatment (JEB WTP)	10	\$ 2.00	810	\$ 5,916,200
Cover Drain Water Collection System				\$ 100,000
Building Demolition & Removal		<i>Hourly rate</i>	<i>Hours required</i>	<i>Cost</i>
	<i>Qty</i>			
CAT Hydraulic Excavator 345C	1	\$ 329.00	12	\$ 3,948
CAT Dozer D8N w/ ripper	1	\$ 345.00	12	\$ 4,140
CAT Front End Loader 992D	1	\$ 626.00	7	\$ 4,382
Rock Truck - 40 ton	4	\$ 332.00	7	\$ 9,296
Flat Deck with 12 ton crane	1	\$ 180.00	20	\$ 3,600
Vacuum Truck	1	\$ 401.00	3	\$ 1,203
General Labourer	2	\$ 65.00	20	\$ 2,600
Concrete Fracturing	<i>Area</i>	<i>Cost</i>		
	<i>m²</i>	<i>per m²</i>		<i>Cost</i>

**Table B2.4
Planning Envelope #3 - JEB Tailings Management Facility (TMF)**

	223	\$ 33.00		\$ 7,372
Till Cover Over Concrete		<i>Hourly</i>	<i>Hours</i>	
	<i>Qty</i>	<i>rate</i>	<i>required</i>	<i>Cost</i>
CAT Front End Loader 988F	1	\$ 284.00	6	\$ 1,704
Rock Truck - 40 ton	2	\$ 332.00	6	\$ 3,984
CAT Dozer D6T w/ ripper	1	\$ 291.00	4	\$ 1,164
Culvert Removal & Cross Ditching		<i>Hourly</i>	<i>Hours</i>	
	<i>Qty</i>	<i>rate</i>	<i>required</i>	<i>Cost</i>
CAT Hydraulic Excavator 345C	2	\$ 329.00	5	\$ 3,290
Flat Deck with 12 ton crane	2	\$ 180.00	5	\$ 1,800
Pipeline Removal		<i>Hourly</i>	<i>Hours</i>	
<i>Tailings and Reclaim Pipelines</i>	<i>Qty</i>	<i>rate</i>	<i>required</i>	<i>Cost</i>
CAT Hydraulic Excavator 345C	1	\$ 329.00	30	\$ 9,870
Flat Deck with 12 ton crane	1	\$ 180.00	30	\$ 5,400
General Labourer	1	\$ 65.00	30	\$ 1,950
Dewatering Well Infrastructure Decommissioning		<i>Hourly</i>	<i>Hours</i>	
<i>Physical Well Decommissioning:</i>	<i>Qty</i>	<i>rate</i>	<i>required</i>	<i>Cost</i>
CAT Hydraulic Excavator 345C	1	\$ 329.00	12	\$ 3,948
Rock Truck - 40 ton	1	\$ 332.00	12	\$ 3,984
General Labourer	2	\$ 65.00	12	\$ 1,560
<i>Powerline Removal:</i>				
CAT Hydraulic Excavator 345C	1	\$ 329.00	20	\$ 6,580
Flat Deck with 12 ton crane	2	\$ 180.00	10	\$ 3,600
General Labourer	2	\$ 65.00	30	\$ 3,900
<i>Road Scarification:</i>				
CAT Grader 14H w/ scarifier	1	\$ 304.00	4	\$ 1,216
Revegetation		<i>Cost</i>	<i>Area</i>	
		<i>per ha</i>	<i>(ha)</i>	<i>Cost</i>
Grass		\$ 5,449.36	16.0	\$ 87,190
Trees		\$ 4,064.50	9.6	\$ 39,019
Subtotal				\$ 48,594,824
Contingency			15.0%	\$ 7,289,224
Total Decommissioning Estimate				\$ 55,884,047

**Table B2.5
Planning Envelope #4 - Permanent Camp Area**

Building Demolition & Removal				
	<i>Qty</i>	<i>Cost per hour</i>	<i>Hours required</i>	<i>Cost</i>
CAT Hydraulic Excavator 345C	1	\$ 329.00	65	\$ 21,385
CAT Dozer D8N w/ ripper	1	\$ 345.00	45	\$ 15,525
CAT Front End Loader 988F	1	\$ 284.00	85	\$ 24,140
Rock Truck - 40 ton	2	\$ 332.00	85	\$ 56,440
CAT Grader 14H w/ scarifier	1	\$ 304.00	20	\$ 6,080
Flat Deck with 12 ton crane	1	\$ 180.00	70	\$ 12,600
General Labourer	3	\$ 65.00	140	\$ 27,300
Concrete Fracturing				
		<i>Cost per m²</i>	<i>Area (m²)</i>	<i>Cost</i>
		\$ 33.00	9,166	\$ 302,491
Till Cover Over Concrete				
	<i>Qty</i>	<i>Cost per hour</i>	<i>Hours required</i>	<i>Cost</i>
CAT Front End Loader 988F	1	\$ 284.00	37	\$ 10,413
Rock Truck - 40 ton	2	\$ 332.00	37	\$ 24,346
CAT Dozer D6T w/ ripper	1	\$ 291.00	9	\$ 2,667
Culvert Removal & Cross Ditching				
	<i>Qty</i>	<i>Cost per hour</i>	<i>Hours required</i>	<i>Cost</i>
CAT Hydraulic Excavator 345C	1	\$ 329.00	6	\$ 1,974
Flat Deck with 12 ton crane	1	\$ 180.00	6	\$ 1,080
Road & Disturbed Area Scarification				
	<i>Qty</i>	<i>Cost per hour</i>	<i>Hours required</i>	<i>Cost</i>
CAT Grader 14H w/ scarifier	1	\$ 304.00	16	\$ 4,886
Revegetation				
		<i>Cost per ha</i>	<i>Area (ha)</i>	<i>Cost</i>
Grass		\$ 5,449.36	3.0	\$ 16,348
Trees		\$ 4,064.50	3.0	\$ 12,194
Subtotal				\$ 539,869
Contingency			15.0%	\$78,779
Total Decommissioning Estimate				\$ 620,849

**Table B2.6
Planning Envelope #5 - Sue Mining Area**

Sue C/A water treatment spans a 5 year period providing continuous water treatment during the 2 year post-operational period and 3 years during the decommissioning period. The unit cost is based on current actual Sue WTP operational costs inclusive of operator wages, reagents, supplies, maintenance, and power.

Sue C/A Pit Water Treatment	<i>Years of Treatment</i>	<i>Cost per m³</i>	<i>Rate (m³/day)</i>	<i>Cost</i>
Drawdown to Construct Till Cap				
Water Treatment (Sue WTP)	3	\$ 1.68	3,500	\$ 6,434,791
Sue C/A Till Backfill		<i>Cost per hour</i>	<i>Hours required</i>	<i>Cost</i>
	<i>Qty</i>			
CAT Front End Loader 992D	1	\$ 626.00	484	\$ 302,836
Rock Truck - 100 ton	2	\$ 468.00	484	\$ 452,802
CAT Dozer D8N w/ ripper	1	\$ 345.00	484	\$ 166,898
Concrete Fracturing		<i>Cost per m²</i>	<i>Area (m²)</i>	<i>Cost</i>
		\$ 33.00	984	\$ 32,460
Till Cover Over Concrete		<i>Cost per hour</i>	<i>Hours required</i>	<i>Cost</i>
	<i>Qty</i>			
CAT Front End Loader 988F	1	\$ 284.00	2	\$ 466
Rock Truck - 40 ton	2	\$ 332.00	2	\$ 1,089
CAT Dozer D6T w/ ripper	1	\$ 291.00	2	\$ 477
Culvert Removal & Cross Ditching		<i>Cost per hour</i>	<i>Hours required</i>	<i>Cost</i>
	<i>Qty</i>			
CAT Hydraulic Excavator 345C	1	\$ 329.00	32	\$ 10,528
Flat Deck with 12 ton crane	1	\$ 180.00	32	\$ 5,760
Waste Rock Stockpile Recontouring		<i>Cost per hour</i>	<i>Hours required</i>	<i>Cost</i>
	<i>Qty</i>			
CAT Grader 14H w/ scarifier	1	\$ 304.00	19	\$ 5,786
CAT Dozer D8N w/ ripper	2	\$ 345.00	317	\$ 218,883
Overburden Stockpile Recontouring		<i>Cost per hour</i>	<i>Hours required</i>	<i>Cost</i>
	<i>Qty</i>			
CAT Grader 14H w/ scarifier	1	\$ 304.00	5	\$ 1,476
CAT Dozer D8N w/ ripper	1	\$ 345.00	35	\$ 12,153
Road & Disturbed Area Scarification		<i>Cost per hour</i>	<i>Hours required</i>	<i>Cost</i>
	<i>Qty</i>			
CAT Grader 14H w/ scarifier	1	\$ 304.00	75	\$ 22,693
CAT Dozer D6T w/ ripper	1	\$ 291.00	33	\$ 9,655
Ponds, Pipelines, Utilities		<i>Cost per hour</i>	<i>Hours required</i>	<i>Cost</i>
	<i>Qty</i>			
CAT Dozer D8N w/ ripper	1	\$ 345.00	36	\$ 12,508
CAT Front End Loader 992D	1	\$ 626.00	4	\$ 2,504
Rock Truck - 100 ton	2	\$ 468.00	8	\$ 7,488
CAT Front End Loader 988F	1	\$ 284.00	50	\$ 14,200
Rock Truck - 40 ton	2	\$ 332.00	50	\$ 33,200
Flat Deck with 12 ton crane	1	\$ 180.00	220	\$ 39,600
General Labourer	2	\$ 65.00	250	\$ 32,500
Revegetation		<i>Cost per ha</i>	<i>Area (ha)</i>	<i>Cost</i>
Grass		\$ 5,449.36	99.0	\$ 539,486
Trees		\$ 4,064.50	83.7	\$ 340,199
Subtotal				\$ 8,700,438
Contingency			15.0%	\$ 1,282,990
Total Decommissioning Estimate				\$ 10,005,504

**Table B2.7
Planning Envelope #6 - Sue Site Facilities**

Building Demolition & Removal				
	<i>Qty</i>	<i>Cost per hour</i>	<i>Hours required</i>	<i>Cost</i>
CAT Hydraulic Excavator 345C	1	\$ 329.00	115	\$ 37,835
CAT Dozer D8N w/ ripper	1	\$ 345.00	50	\$ 17,250
CAT Front End Loader 992D	1	\$ 626.00	41	\$ 25,666
Rock Truck - 100 ton	2	\$ 468.00	46	\$ 43,056
CAT Grader 14H w/ scarifier	1	\$ 304.00	4	\$ 1,216
Flat Deck with 12 ton crane	1	\$ 180.00	30	\$ 5,400
Vacuum Truck	1	\$ 401.00	3	\$ 1,203
General Labourer	3	\$ 65.00	40	\$ 7,800
Concrete Fracturing				
		<i>Cost per m²</i>	<i>Area (m²)</i>	<i>Cost</i>
		\$ 33.00	2,708	\$ 89,366
Till Cover Over Concrete				
	<i>Qty</i>	<i>Cost per hour</i>	<i>Hours required</i>	<i>Cost</i>
CAT Front End Loader 988F	1	\$ 284.00	5	\$ 1,424
Rock Truck - 40 ton	2	\$ 332.00	5	\$ 3,329
CAT Dozer D6T w/ ripper	1	\$ 291.00	5	\$ 1,459
Culvert Removal & Cross Ditching				
	<i>Qty</i>	<i>Cost per hour</i>	<i>Hours required</i>	<i>Cost</i>
CAT Hydraulic Excavator 345C	1	\$ 329.00	6	\$ 1,974
Flat Deck with 12 ton crane	1	\$ 180.00	6	\$ 1,080
Ponds, Pipelines, Utilities				
	<i>Qty</i>	<i>Cost per hour</i>	<i>Hours required</i>	<i>Cost</i>
CAT Dozer D8N w/ ripper	1	\$ 345.00	53	\$ 18,246
CAT Front End Loader 992D	1	\$ 626.00	60	\$ 37,560
Rock Truck - 100 ton	2	\$ 468.00	60	\$ 56,160
Flat Deck with 12 ton crane	1	\$ 180.00	80	\$ 14,400
General Labourer	3	\$ 65.00	160	\$ 31,200
Road & Disturbed Area Scarification				
	<i>Qty</i>	<i>Cost per hour</i>	<i>Hours required</i>	<i>Cost</i>
CAT Grader 14H w/ scarifier	1	\$ 304.00	15	\$ 4,505
CAT Dozer D6T w/ ripper	1	\$ 291.00	150	\$ 43,650

Table B2.7				
Planning Envelope #6 - Sue Site Facilities				
Revegetation		<i>Cost</i>	<i>Area</i>	
		<i>per ha</i>	<i>(ha)</i>	<i>Cost</i>
Grass		\$ 5,449.36	4.0	\$ 21,797
Trees		\$ 4,064.50	5.0	\$ 20,323
Subtotal				\$ 485,898
Contingency			15.0%	\$ 66,932
Total Decommissioning Estimate				\$ 558,783

**Table B2.8
Planning Envelope #7 - Sink/Vulture Treated Effluent Management
System (S/V TEMS)**

Decommissioning of the S/V TEMS includes breaching of water containment structures and

Dam Breaching & Structure Removal				
	<i>Qty</i>	<i>Cost per hour</i>	<i>Hours required</i>	<i>Cost</i>
CAT Dozer D8N w/ ripper	1	\$ 345.00	50	\$ 17,250
CAT Hydraulic Excavator 345C	1	\$ 329.00	50	\$ 16,450
Crawler Crane - 50 ton	1	\$ 256.00	20	\$ 5,120
CAT Front End Loader 992D	1	\$ 626.00	15	\$ 9,390
Rock Truck - 100 ton	2	\$ 468.00	15	\$ 14,040
General Labourer	2	\$ 65.00	20	\$ 2,600
Concrete Fracturing				
		<i>Cost per m²</i>	<i>Area (m²)</i>	<i>Cost</i>
		\$ 33.00	85.7	\$ 2,828
Till Cover Over Concrete				
	<i>Qty</i>	<i>Cost per hour</i>	<i>Hours required</i>	<i>Cost</i>
CAT Front End Loader 988F	1	\$ 284.00	1	\$ 284
Rock Truck - 40 ton	2	\$ 332.00	2	\$ 1,328
CAT Dozer D6T w/ ripper	1	\$ 291.00	4	\$ 1,164
Till Cover Over Iron Precipitates				
<i>Below JEB WTP discharge area</i>	<i>Qty</i>	<i>Cost per hour</i>	<i>Hours required</i>	<i>Cost</i>
CAT Front End Loader 988F	1	\$ 284.00	20	\$ 5,680
Rock Truck - 40 ton	2	\$ 332.00	20	\$ 13,280
CAT Dozer D6T w/ ripper	1	\$ 291.00	40	\$ 11,640
Road & Side slope Scarification				
	<i>Qty</i>	<i>Cost per hour</i>	<i>Hours required</i>	<i>Cost</i>
CAT Grader 14H w/ scarifier	1	\$ 304.00	2	\$ 729
CAT Dozer D6T w/ ripper	1	\$ 291.00	81	\$ 23,538
Revegetation				
		<i>Cost per Ha</i>	<i>Area (ha)</i>	<i>Cost</i>
Grass		\$ 5,449.36	2.6	\$ 14,046
Subtotal				\$ 139,367
Contingency			15.0%	\$ 19,132
Total Decommissioning Estimate				\$ 160,272

**Table B2.9
Planning Envelope #8 - (i) Ancillary Facilities**

Building Demolition & Removal				
	<i>Qty</i>	<i>Cost per hour</i>	<i>Hours required</i>	<i>Cost</i>
Gatehouse, Moffat, Substation				
CAT Front End Loader 988F	1	\$ 284.00	15	\$ 4,260
Rock Truck - 40 ton	2	\$ 332.00	15	\$ 9,960
Flat Deck with 12 ton crane	1	\$ 180.00	15	\$ 2,700
Concrete Fracturing				
		<i>Cost per m²</i>	<i>Area (m²)</i>	<i>Cost</i>
		\$ 33.00	155	\$ 5,121
Till Cover Over Concrete				
	<i>Qty</i>	<i>Cost per hour</i>	<i>Hours required</i>	<i>Cost</i>
CAT Front End Loader 988F	1	\$ 284.00	3	\$ 852
Rock Truck - 40 ton	2	\$ 332.00	3	\$ 1,992
CAT Dozer D6T w/ ripper	1	\$ 291.00	3	\$ 873
Culvert Removal & Cross Ditching				
	<i>Qty</i>	<i>Cost per hour</i>	<i>Hours required</i>	<i>Cost</i>
CAT Hydraulic Excavator 345C	1	\$ 329.00	15	\$ 4,935
Flat Deck with 12 ton crane	1	\$ 180.00	15	\$ 2,700
Road & Disturbed Area Scarification				
	<i>Qty</i>	<i>Cost per hour</i>	<i>Hours required</i>	<i>Cost</i>
CAT Grader 14H w/ scarifier	1	\$ 304.00	169	\$ 51,336
CAT Dozer D6T w/ ripper	1	\$ 291.00	250	\$ 72,750
Ponds, Pipelines, Utilities				
	<i>Qty</i>	<i>Cost per hour</i>	<i>Hours required</i>	<i>Cost</i>
Crawler Crane - 50 ton	1	\$ 256.00	616	\$ 157,696
CAT Dozer D8N w/ ripper	1	\$ 345.00	300	\$ 103,500
CAT Front End Loader 992D	1	\$ 626.00	150	\$ 93,900
Rock Truck - 100 ton	2	\$ 468.00	150	\$ 140,400
CAT Front End Loader 988F	1	\$ 284.00	100	\$ 28,400
Rock Truck - 40 ton	2	\$ 332.00	100	\$ 66,400
Flat Deck with 12 ton crane	1	\$ 180.00	700	\$ 126,000
General Labourer	2	\$ 65.00	300	\$ 39,000
SaskPower 115kV Line				<i>Cost</i>
Demolition and Removal	<i>Lump Sum</i>			\$ 544,500

Table B2.9 Planning Envelope #8 - (i) Ancillary Facilities				
Revegetation		<i>Cost</i>	<i>Area</i>	
		<i>per ha</i>	<i>(ha)</i>	<i>Cost</i>
Grass		\$ 5,449.36	52.8	\$ 287,944
Trees		\$ 4,064.50	79.3	\$ 322,152
Subtotal				\$ 2,067,370
Contingency			15.0%	\$ 210,221
Total Decommissioning Estimate				\$ 2,377,476

**Table B2.10
Planning Envelope #8- (ii) McClean Mining Site**

Mining Pad Material Removal and Disposal				
	<i>Qty</i>	<i>Cost per hour</i>	<i>Hours required</i>	<i>Cost</i>
CAT Dozer D8N w/ ripper	1	\$ 345.00	57	\$ 19,719
CAT Front End Loader 992D	1	\$ 626.00	22	\$ 13,772
Rock Truck - 100 ton	2	\$ 468.00	69	\$ 64,199
Flat Deck with 12 ton crane	1	\$ 180.00	25	\$ 4,500
General Labourer	2	\$ 65.00	30	\$ 3,900
Access Road and Clean Laydown Area Scarification				
	<i>Qty</i>	<i>Cost per hour</i>	<i>Hours required</i>	<i>Cost</i>
CAT Grader 14H w/ scarifier	1	\$ 304.00	2	\$ 608
CAT Dozer D6T w/ ripper	1	\$ 291.00	4	\$ 1,190
Mining Pad Slope Grading and Scarification				
	<i>Qty</i>	<i>Cost per hour</i>	<i>Hours required</i>	<i>Cost</i>
CAT Grader 14H w/ scarifier	1	\$ 304.00	3	\$ 912
CAT Dozer D8N w/ ripper	2	\$ 345.00	10	\$ 6,608
Sedimentation & Clarification Ponds				
	<i>Qty</i>	<i>Cost per hour</i>	<i>Hours required</i>	<i>Cost</i>
CAT Grader 14H w/ scarifier	1	\$ 304.00	1	\$ 401
CAT Dozer D8N w/ ripper	1	\$ 345.00	9	\$ 3,034
CAT Front End Loader 992D	1	\$ 284.00	18	\$ 5,112
Rock Truck - 100 ton	2	\$ 332.00	12	\$ 7,709
Pipelines and Utilities				
	<i>Qty</i>	<i>Cost per hour</i>	<i>Hours required</i>	<i>Cost</i>
CAT Dozer D6T w/ ripper	1	\$ 291.00	2	\$ 582
CAT Front End Loader 988F	1	\$ 284.00	4	\$ 1,136
Rock Truck - 40 ton	2	\$ 332.00	4	\$ 2,656
Flat Deck with 12 ton crane	1	\$ 180.00	8	\$ 1,440
General Labourer	2	\$ 65.00	15	\$ 1,950
Culvert Removal & Cross Ditching				
	<i>Qty</i>	<i>Cost per hour</i>	<i>Hours required</i>	<i>Cost</i>
CAT Hydraulic Excavator 345C	1	\$ 329.00	3	\$ 987
Flat Deck with 12 ton crane	1	\$ 180.00	3	\$ 540
Till Cover over Mining Pad				
	<i>Qty</i>	<i>Cost per hour</i>	<i>Hours required</i>	<i>Cost</i>

**Table B2.10
Planning Envelope #8- (ii) McClean Mining Site**

CAT Front End Loader 988F	1	\$ 284.00	4	\$ 1,136
Rock Truck - 40 ton	2	\$ 332.00	13	\$ 8,587
CAT Dozer D6T w/ ripper	1	\$ 291.00	16	\$ 4,516
Revegetation		<i>Cost</i>	<i>Area</i>	
		<i>per Ha</i>	<i>(ha)</i>	<i>Cost</i>
Grass		\$ 5,449.36	3.3	\$ 17,813
Trees		\$ 4,064.50	3.3	\$ 13,286
Subtotal				\$ 186,294
Contingency			25%	\$ 46,573
Total Decommissioning Estimate				\$ 232,867

**Table B2.11
Planning Envelope #9 - Midwest Site**

Building Demolition & Removal				
		<i>Cost</i>	<i>Hours</i>	
	<i>Qty</i>	<i>per hour</i>	<i>required</i>	<i>Cost</i>
CAT Hydraulic Excavator 345C	1	\$ 329.00	9	\$ 3,046
CAT Dozer D8N w/ ripper	1	\$ 345.00	2	\$ 758
CAT Front End Loader 992D	1	\$ 626.00	3	\$ 1,756
Rock Truck - 100 ton	4	\$ 468.00	3	\$ 5,252
Flat Deck with 12 ton crane	1	\$ 180.00	7	\$ 1,212
Vacuum Truck	1	\$ 401.00	17	\$ 6,751
General Labourer	2	\$ 65.00	34	\$ 4,377
Concrete Fracturing				
		<i>Cost</i>	<i>Area</i>	
		<i>per m²</i>	<i>m²</i>	<i>Cost</i>
		\$ 33.00	1,049	\$ 34,603
Till Cover Over Concrete				
		<i>Cost</i>	<i>Hours</i>	
	<i>Qty</i>	<i>per hour</i>	<i>required</i>	<i>Cost</i>
CAT Front End Loader 988F	1	\$ 284.00	2	\$ 568
Rock Truck - 40 ton	2	\$ 332.00	2	\$ 1,160
CAT Dozer D6T w/ ripper	1	\$ 291.00	3	\$ 915
Pipeline Removal				
		<i>Cost</i>	<i>Hours</i>	
	<i>Qty</i>	<i>per hour</i>	<i>required</i>	<i>Cost</i>
CAT Hydraulic Excavator 345C	1	\$ 329.00	19	\$ 6,320
Flat Deck with 12 ton crane	1	\$ 180.00	38	\$ 6,916
General Labourer	2	\$ 65.00	38	\$ 4,995
Pond Liner Removal and Grading				
		<i>Cost</i>	<i>Hours</i>	
	<i>Qty</i>	<i>per hour</i>	<i>required</i>	<i>Cost</i>
CAT Hydraulic Excavator 345C	1	\$ 329.00	8	\$ 2,632
CAT Dozer D6T w/ ripper	1	\$ 291.00	22	\$ 6,338
Flat Deck with 12 ton crane	1	\$ 180.00	20	\$ 3,600
General Labourer	2	\$ 65.00	20	\$ 2,600
Culvert Removal & Cross Ditching				
		<i>Cost</i>	<i>Hours</i>	
	<i>Qty</i>	<i>per hour</i>	<i>required</i>	<i>Cost</i>
CAT Hydraulic Excavator 345C	1	\$ 329.00	6	\$ 1,974
Flat Deck with 12 ton crane	1	\$ 180.00	6	\$ 1,080

**Table B2.11
Planning Envelope #9 - Midwest Site**

Table B2.11 Planning Envelope #9 - Midwest Site				
Road & Disturbed Area Scarification		<i>Cost</i>	<i>Hours</i>	
	<i>Qty</i>	<i>per hour</i>	<i>required</i>	<i>Cost</i>
CAT Grader 14H w/ scarifier	1	\$ 304.00	18	\$ 5,604
CAT Dozer D6T w/ ripper	1	\$ 291.00	4	\$ 1,073
Shaft Seal		<i>Cost</i>	<i>Volume</i>	
		<i>per m³</i>	<i>(m³)</i>	<i>Cost</i>
Concrete Plug		600	10	\$6,000
Concrete Plug Engineering Design and Shaft Stability Assessment				\$30,000
		<i>Cost</i>	<i>Hours</i>	
	<i>Qty</i>	<i>per hour</i>	<i>required</i>	<i>Cost</i>
CAT Front End Loader 988F	1	\$ 284.00	1	\$ 284
Rock Truck - 40 ton	1	\$ 332.00	1	\$ 332
CAT Dozer D6T w/ ripper	1	\$ 291.00	1	\$ 291
General Labourer	4	\$ 65.00	5	\$ 1,300
Revegetation		<i>Cost</i>	<i>Area</i>	
		<i>per Ha</i>	<i>(ha)</i>	<i>Cost</i>
Grass		\$ 5,449.36	4.4	\$ 23,825
Trees		\$ 4,064.50	13.1	\$ 53,311
Subtotal				\$ 218,873
Contingency			15.0%	\$ 32,831
Total Decommissioning Estimate				\$ 251,704

Table B2.12
General - Cost Assumptions and Unit Rates

Work Schedule			Units
	Summer Field Season (April 1 to October 1)	27	weeks
	Work Shift - 2 weeks in/ 2 weeks out schedule	24	weeks
	Working Day	10	hrs/day
	Person-days per Season	168	days/season/person
	Total days per Season	189	days per season
	Person-hours per season	1,680	hours/season/person
CNSC Fees			
		\$ 438,034	per year
Air Transportation			
	ATR 42 (40 passenger)	\$ 14,000	/return trip
	Beechcraft 1900 (18 passenger)	\$ 11,000	/return trip
	King Air 200 (8 passenger)	\$ 6,500	/return trip
Freight			
	Saskatoon/McClean -6 axle truck/trailer, 30 t load	\$ 4,300	/return trip
Food & Lodging at McClean Lake Operation			
	Per person-day	\$ 80	/person-day
Fuel Cost (delivered to McClean Lake)			
	Diesel	\$ 1.35	per litre
	Gasoline	\$ 1.33	per litre
	Propane	\$ 0.43	per litre
Labour Cost (including burden)			
	General Labourer	\$ 65	per hour
	Equipment Operator	\$ 75	per hour
	Contract Superintendent	\$ 151	per hour
	Security (per Person)	\$ 15,697	per month
Revegetation (includes labour, equipment & supplies)			
	Areas revegetated with grass	\$ 5,449	per hectare
	Areas revegetated with trees	\$ 4,065	per hectare

**Table B2.12
General - Cost Assumptions and Unit Rates**

General Production Rates ¹			
	Grader Scarifying Rate	4,000	m ² /hr
	Grader Grading Rate	12,240	m ² /hr
	Dozer Level Grading	1,000	m ² /hr
	Dozer Slope Grading	200	m ² /hr
	Dozer General Cleanup	600	m ² /hr
	Production Rate - 2 trucks - short haul	600	m ³ /hr
	Production Rate - 2 trucks - long haul	250	m ³ /hr
	Production Rate - 4 trucks	540	m ³ /hr
	Production Rate - 6 trucks	810	m ³ /hr
Other Construction and Demolition Rates			
	Concrete	\$ 600	/m ³
	Concrete Fracturing ²	\$ 33	/m ²
	Mill Building Demolition ³	\$ 294	/m ²
Financial Rates			
	Inflation Rate	2.0%	
	Escalation Rate	1.8%	
	Discount Rate	3.03%	

¹ Production rates are based on actual rates at Orano mines using similar equipment.

² Concrete fracturing rate assumes an average 0.5 m slab thickness.

³ Mill demolition rate is inclusive of removal of interior equipment and piping, exterior cladding, structure demolition, concrete slab fracturing, and hauling of waste for disposal in the JEB TMF. Rate based on Cluff Lake mill demolition costs with 50% escalation applied.

**Table B2.13
General - Equipment Rental Rates**

Equipment rental rates utilized for decommissioning estimates are based on:

-2024 SHCA Equipment Rental Rates Guide

-Current Contracted Equipment Rates at McClean Lake Operation

Equipment rental rates are inclusive of operator, fuel, and maintenance costs.

Equipment Type	Hourly Rate
Flat Deck with 12 ton crane	\$ 180.00
Crawler Crane - 50 ton	\$ 256.00
CAT Grader 14H w/ scarifier	\$ 304.00
CAT Dozer D6T w/ ripper	\$ 291.00
CAT Dozer D8N w/ ripper	\$ 345.00
CAT Front End Loader 988F	\$ 284.00
CAT Front End Loader 992D	\$ 626.00
CAT Hydraulic Excavator 345C	\$ 329.00
Rock Truck - 40 ton	\$ 332.00
Rock Truck - 100 ton	\$ 468.00
Vacuum Truck	\$ 401.00
Till and Waste Rock Haul Rate	Unit Rate
	<i>per m³ /km</i>
Rock Truck - 40 ton	\$ 15.11

Table B2.14
Summary of Changes to Unit Rates

<i>Item</i>	<i>1999</i>	<i>2004</i>	<i>2008</i>	<i>2016</i>	<i>2021</i>	<i>2024</i>	<i>Unit</i>	<i>Comment</i>
Labourer	N/A	N/A	N/A	\$46.00	\$52.00	\$65.00	/hr	Based on 2024 collective bargaining agreement and 2023 contract labour rates.
Equipment Operator	\$23.00	\$25.32	\$33.00	\$56.00	\$70.00	\$75.00	/hr	Based on 2024 collective bargaining agreement and 2023 contract labour rates.
Equipment Rental Rates	\$159.52	\$238.53	\$295.72	\$330.00	\$320.73	\$346.91	/hr	Average hourly rate. Based on 2024 SHCA rates and 2023 McClean construction project rates.
Building Demolition Cost	\$200.00	\$196.18	\$235.42	\$282.50	\$294.27	\$294.27	/m ²	50% escalation of Cluff Lake mill decommissioning costs and aligns with current industry rates.
Concrete Demolition	\$2.70	\$8.17	\$75.00	\$32.00	\$33.00	\$33.00	/m ²	Keep previous version rate that aligns with partner operations rates.
Till Cover Over Foundations	0.75	0.3	0.3	0.3	0.3	0.3	m	Based on Cluff Lake decommissioning and radiological clearance experience.
Grader Scarification Rate	3000	4,000 - 12,000	4,000 - 12,000	4,000 - 12,000	4,000 - 12,000	4,000 - 12,000	m ² /hr	Based on site experience production rates for grading and scarifying.
Revegetation	4,000 - 6,500	2,262 - 3,343	3,054 - 4,504	3,359 - 4,954	3,359 - 4,954	4,065 - 5,449	/ha	Based on actual escalated costs and conservative industry average for revegetation.
Air Transport - ATR 42	\$9,000.00	\$12,267.00	\$15,750.00	\$18,000.00	\$12,000.00	\$14,000.00	return	Escalation of 2021 cost
- Beechcraft 1900	N/A	N/A	N/A	\$11,000.00	\$10,000.00	\$11,000.00	return	Escalation of 2021 cost
- King Air 200	\$3,500.00	\$3,800.00	\$6,300.00	\$7,500.00	\$5,600.00	\$6,500.00	return	Escalation of 2021 cost
Freight Truck	\$2,800.00	\$2,374.94	\$3,393.00	\$4,700.00	\$4,700.00	\$4,300.00	return	2024 average NRT transport contract rate.
Diesel	\$0.45	\$0.60	\$1.10	\$1.42	\$1.25	\$1.35	litre	2024 contract price delivered to site.
Gasoline	\$0.60	\$0.75	\$1.00	\$1.29	\$1.25	\$1.33	litre	2024 contract price delivered to site.
Food & Lodging	\$70.00	\$58.91	\$64.43	\$100.00	\$80.00	\$80.00	/person-day	2024 McClean Lake overhead rate.

**Material Estimate for the McClean Lake Mine
Operation Site**

Table B2.15 General - Material Quantities							
<i>Area</i>	<i>Item</i>	<i>Concrete (m²)</i>	<i>Cladding (m²)</i>	<i>Insulated (Yes/No)</i>	<i>Structural Steel (t)</i>	<i>Wood (t)</i>	<i>Other¹ (t)</i>
JEB Mining Area	Fuel tank pad	207					10
	Oil tank pad	111					10
	Former shop pad	289					10
	Powerhouse pad	550					
	Maintenance shop	630	1,238	Yes			
	Loader Storage		745	Yes		1	
	Construction Offices		492	Yes		10	
	Miscellaneous	50	1,000	No		5	500
	McClean Mill Area	Grinding	601	1321	Yes	100	
Slurry Receiving		1,275	2804	Yes	50		
Leaching		921	1935	Yes	40		
CCD		708	955	Yes	80		
Pregnant Aqueous Clarification		734	1616	Yes	40		
CCC		245	539	Yes	15		
SX		1,367	3008	Yes	50		
SX Plant		1,858	3,943	Yes	54		127
Strip Purification and Precipitation		1,335	2,803	Yes	50		
Calcining		514	1,080	Yes	80		
Yellowcake and Reagent Storage		688	1,281	Yes	10		
YC Storage Building Dock		32					
Tailings Neutralization		935	2,732	Yes	15		
Tailings Thickener Pad		1,414					
Ammonia Crystallization		553	639	Yes	10		15
Acid Plant		931	2,514	Yes	20		
Oxygen Plant		1,061	2865	Yes	50		
Utilidor		856	2,311	Yes	40		
Pumphouse		26	71	Yes	15		
Mill Dry and Offices		2,869	10,040	Yes	120		
Warehouse Dock		244					
Reagents		1,115	2,341	Yes			
Water Treatment Plant		2,170	6,292	Yes	1,500		20
WTP pumphouse		100	271	Yes			
Propane Vaporizers		103			500		
Magnetite Coverall Building		701	1,052	No	2		
Services Shop		454	943	Yes	10		
Maintenance Storage Coverall		241	500	No	1		
Hazardous Materials Pad		420					10
Powerhouse		550			10		
Miscellaneous -Walkways, Sheds, etc.	397	1,000	No		1,500	1,000	
JEB TMF Area	Dewatering Wells	21	30	Yes	3	3	3
	Raise water Pumphouse	130	303	Yes			
	Pressure Control Station	34	108	Yes			
	Miscellaneous	20			20	20	
Permanent Camp	Camp & Gym	9,041	9,932	Yes	10	50	
	Water Treatment Plant	67	149	Yes			
	Tennis Court	475					
	Pat Lake Pumphouse	43	122	Yes			
	Miscellaneous	15	700	No	30	400	
Sue Mining Area	Scanner	86	60	Yes	15	10	
	Fuel Tank Pad	258					10
	Drill shop	507	967	Yes			
	Tower Bases	7			15	10	20
	Transformer Base	86					
	Sue C Contaminated Landfill						21,023
	Miscellaneous	39	200	No	30	30	20
Sue Site Facilities	Coverall Buildings	15	2,000	No			
	Sue Warehouse	12	189	Yes			
	Water Treatment Plant	512	982	Yes			
	Tank Supports, etc	25			1,100	500	10
	Lube Containment Area	30					5
	Pumphouse	55	148	Yes	10		
	Sed Pond Ramp	118					

**Table B2.15
General - Material Quantities**

<i>Area</i>	<i>Item</i>	<i>Concrete (m²)</i>	<i>Cladding (m²)</i>	<i>Insulated (Yes/No)</i>	<i>Structural Steel (t)</i>	<i>Wood (t)</i>	<i>Other¹ (t)</i>
	Utilities Building	180	356	Yes	10		
	HD Shop	1,038	1,978	Yes	10		
	Tire Pad	331					
	Cold Storage Pad	168					
	Welding Bay Pad	223					
S/V TEMS	Sink Reservoir Control Structure	37			3		
	Vulture Outflow	49					
Ancillary	Gatehouse scale	95			2		
	Substation	25	95	Yes			
	Miscellaneous	100	700		30	15	2,700
McClellan Mining	Concrete Pads	613					
	Piping, HDPE Liner						40
Midwest (current)	WTP	194	6,400	Yes	2		
	Headframe	531			3		
	Pump station 1	10	87	No			
	Pump station 2	4	14	No			
	Concrete Pads	304					
	Sedimentation Ponds						150
	John Pond Weir	20					
	Miscellaneous	50	20	No		2	150
Total (tonnes)²		70,255	26,765	10,945	n/a	4,155	2,556

¹ Other waste includes contaminated material inventory and miscellaneous mixed wastes.

² Assumptions: Concrete average thickness of 0.5 m and density of 1.25 t/m³. Demolished cladding 0.15 m³/m²; mixed demolition waste density of 0.87 t/m³.

Table B2.16
General - Changes to Rubble Volumes

<i>Rubble Type</i>	1999	2004	2008	2016	2021	2025¹	<i>Units</i>
	Version 2	Version 3	Version 7	Version 8	Version 9	Version 10	
Concrete ²	13,125	22,125	28,039	27,011	26,707	26,765	tonnes
Cladding ³	8,483	10,362	11,910	11,745	10,918	10,945	tonnes
Steel ⁴	4,000	6,363	9,118	4,124	4,155	4,155	tonnes
Wood ⁵	2,000	2,760	3,840	2,542	2,556	2,556	tonnes
Miscellaneous (HDPE liner, pipe, etc.)	2,000	2,700	3,220	4,717	4,810	4,810	tonnes
Total ⁶	29,608	44,310	56,128	50,139	49,146	49,232	tonnes

¹ Relatively small change in rubble volume reflects no major mill expansion or construction activities

² Concrete volume calculation refined to reflect a more precise approximation of slab areas, average concrete slab thickness (0.5 m), and rubble density of 1.25 t/m³.

³ Cladding volume calculated using a conversion factor of 0.15 m³/m² and 0.87 t/m³.

⁴ Steel waste is lower than in previous versions due to a more accurate accounting of steel inventory onsite.

⁵ Wood waste volume is lower than previous versions due to a more accurate accounting of wood structure inventory onsite.

⁶ Rubble volumes are now presented in consistent units to facilitate comparison between rubble types and total waste volumes.

**Table B2.17
General - Camp and Operational Costs**

Camp and Power

Cost estimate provides for operating an annual temporary camp from April to October. It is assumed that the majority of the work would be conducted during the 3rd, 4th and 5th field seasons, after the 2 year post-operational period. Field seasons 6 to 10 would involve a limited crew during potential year round water treatment operations at the JEB and Sue sites and environmental monitoring. Costs are identified below for catering, janitorial services, and generator fuel.

i) Room & Board ¹						
		<i>Field</i>		<i>Cost per</i>	<i>Field Season</i>	
<i>Period</i>		<i>seasons</i>	<i>Personnel</i>	<i>person/day</i>	<i>Days</i>	<i>Cost</i>
Initial Decommissioning		3	62	\$80.00	185	\$ 2,752,800
Interim Monitoring		8	5	\$80.00	365	\$ 1,168,000
Final Decommissioning		1	25	\$80.00	185	\$ 370,000
					Subtotal	\$ 4,290,800

ii) Generator Fuel

	<i>Field</i>	<i>Consumption</i>	<i>Run time</i>	<i>Cost per</i>	<i>Field Season</i>	<i>Cost</i>
	<i>seasons</i>	<i>litres/hr</i>	<i>hrs/day</i>	<i>litre</i>	<i>Days</i>	
Initial Decommissioning	3	20	24	\$ 1.35	185	\$ 359,640
Interim Monitoring	8	20	24	\$ 1.35	365	\$ 1,892,160
Final Decommissioning	1	20	24	\$ 1.35	185	\$ 119,880
					Subtotal	\$ 2,371,680

Mobilization and Demobilization

Cost for mobilization and demobilization of contractor heavy equipment to and from site for the initial and final decommissioning periods based on current contract rates.

			<i>Field Seasons</i>	<i>Cost per yr</i>	<i>Cost</i>
Equipment Mobilization/Demobilization			4	\$500,000	\$ 2,000,000

Air Travel

Personnel will work on a two week in / two week out rotational basis.

		<i>Field</i>	<i>Flights</i>	<i>Unit Cost</i>	
	<i>Aircraft</i>	<i>seasons</i>	<i>per season</i>	<i>per flight</i>	<i>Cost</i>
Initial Decommissioning	ATR 42	3	13	\$14,000	\$ 546,000
Interim Monitoring	King Air 200	8	26	\$ 6,500	\$ 1,352,000
Final Decommissioning	King Air 200	1	13	\$ 6,500	\$ 84,500

Freight

Allowance for transport of required equipment on site other than those covered in mob/demob costs of contractors.

		<i>Field</i>	<i>Trips</i>	<i>Unit Cost</i>	
		<i>seasons</i>	<i>per season</i>	<i>per trip</i>	<i>Cost</i>
Initial Decommissioning		3	21	\$4,300	\$ 270,900

Table B2.17						
General - Camp and Operational Costs						
Interim Monitoring			8	4	\$4,300	\$ 137,600
Final Decommissioning			1	8	\$4,300	\$ 34,400
Security						
Allowance for continuous site security presence for physical decommissioning years 3 to 5 and year round water treatment operations for years 6 to 10. Security for the two year post-operational period are included in the post-operational cost summary.						
			<i>Field</i>		<i>Unit Cost</i>	
			<i>seasons</i>	<i>Personnel</i>	<i>per year</i>	<i>Cost</i>
Site Security			8	2	\$188,364	\$ 3,013,824
Subtotal						\$ 14,101,704
Contingency					15.0%	\$ 2,053,549
Total for Camp and Operational Costs						\$ 16,216,960

¹ A daily cost per person to onsite personnel to account for room and board, catering and janitorial services, onsite transportation, office space, telephone and internet communications, and provision for recreational activities.

**Table B2.18
General - On-Site Project Management**

<i>Project Staff</i> ¹	<i>Period</i>	<i>Qty</i>	<i>Time per Year</i>	<i>Period (years)</i>	<i>Annual Cost</i>	<i>Cost</i>
Project Manager	Initial Decommissioning	1	0.5	3	\$ 183,277	\$ 274,916
	Final Decommissioning	1	0.5	1	\$ 183,277	\$ 91,639
Site Superintendent	Initial Decommissioning	2	0.5	3	\$ 153,467	\$ 460,402
	Interim Monitoring	1	1	8	\$ 153,467	\$ 1,227,738
	Final Decommissioning	1	1	1	\$ 153,467	\$ 153,467
Project Engineer/Scientist	Initial Decommissioning	2	0.5	3	\$ 122,553	\$ 367,659
	Final Decommissioning	2	0.5	1	\$ 122,553	\$ 122,553
Radiation/Engineering Technicians	Initial Decommissioning	2	0.5	3	\$ 86,118	\$ 258,355
	Interim Monitoring	2	1	8	\$ 86,118	\$ 1,377,893
	Final Decommissioning	2	1	1	\$ 86,118	\$ 172,237
Environment Technicians	Initial Decommissioning	2	1	3	\$ 73,973	\$ 443,840
	Interim Monitoring	2	1	8	\$ 73,973	\$ 1,183,575
	Final Decommissioning	2	1	1	\$ 73,973	\$ 147,947
Surveyors	Initial Decommissioning	2	0.5	3	\$ 86,118	\$ 258,355
	Final Decommissioning	2	0.5	1	\$ 86,118	\$ 86,118
Administration	Initial Decommissioning	1	0.5	3	\$ 55,204	\$ 82,806
	Final Decommissioning	1	0.5	1	\$ 55,204	\$ 27,602
General Supplies and Equipment	Annually	Lump	1	12	\$ 25,000	\$ 300,000
CNSC Fees ²	Initial Decommissioning	Lump	1	3	\$ 438,034	\$ 1,314,103
	Final Decommissioning	Lump	1	1	\$ 438,034	\$ 438,034
Subtotal						\$ 8,789,239
Contingency					15.0%	\$ 1,198,500
Total for Project Management						\$ 10,107,625

¹ Project staff for years 1 and 2 are included in the post-operational period cost summary.

² CNSC fees include applicable decommissioning license fees and regulatory oversight.

**Table B2.19
General - Interim Monitoring**

<i>Item</i>	<i>Qty</i>	<i>Units</i>	<i>Period (yrs)</i>	<i>Unit Cost</i>		<i>Cost</i>
CNSC Fees ¹	1	<i>per yr</i>	8	\$ 438,034	<i>per yr</i>	\$ 3,504,276
Legal Fees	100	<i>hrs</i>	9	\$ 250	<i>per hr</i>	\$ 25,000
Environmental Lab Analyses	180	<i>per yr</i>	9	\$ 750	<i>ea</i>	\$ 1,215,000
Environmental Effects Monitoring Studies	1	<i>ea</i>	1	\$ 212,258	<i>lump</i>	\$ 212,258
Sue Area Hydrogeology & Contaminant Transport Modelling	1	<i>ea</i>	1	\$ 300,000	<i>lump</i>	\$ 300,000
JEB Area Hydrogeology & Contaminant Transport Modelling	1	<i>ea</i>	1	\$ 200,000	<i>lump</i>	\$ 200,000
Environmental Risk Assessment	1	<i>ea</i>	1	\$ 707,833	<i>lump</i>	\$ 707,833
Geotechnical Inspections (e.g. cover settlement, slope, stability, erosion)	1	<i>per yr</i>	5	\$ 22,082	<i>per yr</i>	\$ 110,408
General Site Maintenance (e.g. assume every 3 yrs inspect and improve slope stability, revegetation, etc.)	1	<i>ea</i>	3	\$ 85,779	<i>per yr</i>	\$ 257,338
Engineering (including stability assessments), drawings		<i>lot</i>		\$ 61,616	<i>lump</i>	\$ 61,616
Subtotal						\$ 6,593,730
Contingency					15.0%	\$ 737,598
Total for Interim Monitoring						\$ 7,582,789

¹ CNSC fees for initial and final decommissioning periods are included in the General - Project Management cost estimate

**Table B2.20
General - Post-Closure Monitoring**

<i>Item</i>	<i>Qty</i>	<i>Units</i>	<i>Period (years)</i>	<i>Unit Cost</i>		<i>Cost</i>
CNSC Fees ¹	1	ea	5	\$ 434,034	<i>per yr</i>	\$ 2,190,172
Application for Abandonment ²	1	ea		\$ 1,500,000	<i>lump</i>	\$ 1,500,000
Legal Fees	50	hrs	5	\$ 250	<i>per hr</i>	\$ 12,500
Environmental Monitoring (Consultant)	Qty	Campaigns per year	Period (years)	Unit Cost		Cost
Environmental Technicians	4	4	5	\$ 72,751	<i>per Campaign</i>	\$ 1,592,703
Environmental Coordinator	1	4	5	\$ 16,800	<i>per Campaign</i>	\$ 360,640
Accommodations ³	5	4	5	\$ 21,000	<i>per Campaign</i>	\$ 420,000
Mobilization ⁴	1	4	5	\$ 10,000	<i>per Campaign</i>	\$ 200,000
Laboratory Analyses	180	1	5	\$ 500	<i>per sample</i>	\$ 675,000
Monitoring Report	1	4	5	\$ 11,000	<i>per yr</i>	\$ 111,500
Geotechnical Inspection (cover settlement, slope stability, erosion)	1	1	5	\$ 11,000	<i>per yr</i>	\$ 105,000
Final TOVP Sampling Program and Report	1	ea	1	\$ 1,000,000	<i>lump</i>	\$ 1,000,000
Subtotal						\$ 8,167,515
Contingency					15.0%	\$ 927,527
Total for Post Decommissioning Monitoring						\$ 9,392,642

¹ CNSC fees include the annual license fee for the decommissioned site.

² Assume application for abandonment is filed 5 years after final decommissioning and takes 2 years to assess and approve the application to enter the site into Institutional Control.

³ Accommodations includes the cost of housing personnel at the nearby Points North Landing camp during monitoring campaigns.

⁴ Mobilization includes the cost of ground transportation to McClean Lake from Saskatoon for campaign monitoring.

Table B2.21
General - Inflation of Total Decommissioning Costs

Inflation rate compounded annually for the 5 year planning period

<i>Inflation Rate</i>	<i>Timing</i>	<i>Year</i>	<i>Cost Estimate</i>	<i>Annual Increment</i>	<i>Inflated Annual Cost</i>
2.00%	YEAR 0	2025	\$111,003,994		\$111,003,994
				\$2,220,080	
2.00%	YEAR 1	2026			\$113,224,074
				\$2,264,481	
2.00%	YEAR 2	2027			\$115,488,555
				\$2,309,771	
2.00%	YEAR 3	2028			\$117,798,326
				\$2,355,967	
2.00%	YEAR 4	2029			\$120,154,293
				\$2,403,086	
2.00%	YEAR 5	2030			\$122,557,378
Total Inflation				\$11,553,385	
Total Inflated Value					\$122,557,378

Appendix C PDP History

McClellan Lake Operation Preliminary Decommissioning Plan History

Orano Resources Canada Inc. (Orano) (formerly known as COGEMA Resources Inc., and also AREVA Resources Canada Inc.) is the operator of both the McClellan Lake Operation and the Midwest Project and has maintained decommissioning plans and a financial assurance for both.

Orano submitted a preliminary decommissioning plan (PDP) and proposed financial assurance for the McClellan Lake Project in March 1996. This document provided plans and associated costs for decommissioning the project site prior to the start-up of the McClellan Lake mill (i.e. *JEB mining phase only*), formerly called the JEB mill. The AECB and SERM approved the March 1996 conceptual decommissioning strategy in April 1996, and agreed to a financial assurance amount of \$5,400,000 (CAD). As a result of this agreement, Orano provided a Letter of Credit for \$5,400,000 (CAD) to the Province of Saskatchewan in July 1996.

An updated preliminary decommissioning plan and proposed financial assurance for the McClellan Lake Project was submitted by Orano to the AECB and Saskatchewan Environment and Resource Management (SERM) in March 1997. This draft report provided the plans and associated costs to decommission and reclaim the McClellan Lake Operation site but no agreement was reached at that time between the Company and the regulatory agencies on the plan and associated costs.

Orano produced an updated preliminary decommissioning plan and proposed financial assurance in April 1999. The report provided the plans and estimated costs for decommissioning of the McClellan Lake Operation prior to the expansion of the mill to accommodate Midwest and Cameco Corporation's (Cameco) Cigar Lake Project ore processing at the McClellan Lake mill. The AECB and SERM approved of the plan and the proposed financial assurance of \$35,000,000 (CAD) in May 1999. Orano and the McClellan Lake Operation joint venture partners subsequently provided Letters of Credit payable to the Province of Saskatchewan in the amount of \$35,000,000 (CAD) in June 1999.

In accordance with provincial regulatory requirements (Section 16 of *The Mineral Industry Environmental Protection Regulations, 1996*), Orano is required to review the approved preliminary decommissioning plan and financial assurance fund at least once every five years. Condition 6.2.1r of *Approval to Operate Pollutant Control Facilities – Approval No. IO-183* indicated that the next five year decommissioning plan was to be submitted no later than June 30, 2004. At the request of Orano, an extension of the submission date to September 15, 2004 was approved by Saskatchewan Environment on June 21, 2004. The extension allowed incorporation of the most up-to-date information possible with respect to contractor costs, from Orano's recent decommissioning experience at the Cluff Lake Operation, and changes resulting from the favorable findings of the Tailings Optimization and Validation Program (TOVP).

Saskatchewan Environment reviewed the September 2004 version of the preliminary decommissioning plan, and in response to the reviewers' questions and comments, Orano submitted an addendum to the PDP in March 2005. This addendum also addressed comments made verbally by the CNSC. The information from that addendum was incorporated into an April 2005 submission which included an update to plans for the decommissioning of the Sue mining area.

The Midwest Project is currently in a care and maintenance state. In March 1997, Orano prepared a preliminary decommissioning and reclamation plan for the Midwest Project entitled *Midwest Project – Conceptual Decommissioning Plan*. This plan and the associated financial assurances were approved by the AECB and SERM and updated in 2001 to incorporate clean-up activities that took place between 1997 and 2000.

One of the conditions of the Saskatchewan Ministry of Environment (SMOE) *Approval to Temporarily Close IT-39* for the Midwest Project was that Orano must review the preliminary decommissioning plan and financial assurance before December 1, 2008.

In 2009, Orano consolidated the management of the McClean Lake Operation and Midwest Project under a single licensing and permitting framework and correspondingly consolidated the preliminary decommissioning plans and financial assurances. The 2009 Preliminary Decommissioning and Financial Assurance added the necessary care and maintenance activities to maintain a safe and secure state at the McClean Lake Operation and Midwest Project sites after closure while decommissioning licensing proceeds. Also included was the cost of decommissioning a future open pit (Caribou Project, now known as Sue F) pending regulatory approval and development. A hydraulic cage contingency considered in earlier plans was removed based on the favorable findings in the Tailings Optimization and Validation Program (TOVP). Funding for this contingency measure was removed from the financial assurance due to the very low likelihood that it will ever be required.

Version 10 of the Preliminary Decommissioning Plan and Financial Assurance has been developed to include the cost of decommissioning the McClean Lake Mill and applies revised unit rates representative of current construction industry rates. Information and cost estimates are provided that address water treatment requirements for the dewatering and consolidation phase of the JEB tailings management facility (TMF) as well as the drawdown and treatment of Sue C/A pit water in order to construct a cover over the interred waste during decommissioning. Cost estimates for the decommissioning of the JEB TMF, including a soil cover are included.

Appendix D: Financial Instruments

The financial instruments included in this Appendix are from the McClean Lake Operation Preliminary Decommissioning Plan and Financial Assurance Version 9. The financial instruments will be updated following the hearing for review and acceptance of the financial guarantee and the Record of Decision is issued.



199 Bay Street, Suite 2500
P.O. Box 139, Commerce Court Postal Station
Toronto, ON M5L 1E2
Canada

O (416) 863-0550
F (416) 863-5010

ENDORSEMENT NO. 2

To be attached to and form part of bond number [REDACTED]

Issued on behalf of **ORANO CANADA INC.**

Issued in favour of **HER MAJESTY THE QUEEN IN RIGHT OF THE
PROVINCE OF SASKATCHEWAN, AS REPRESENTED BY THE MINISTER OF
ENVIRONMENT**

IT IS HEREBY UNDERSTOOD AND AGREED THAT the bond amount is amended

from: **\$82,963,588.40**

to: **\$78,971,896.28**

All other terms and conditions of the said bond remain unchanged.

Executed at Toronto this 7th day of **FEBRUARY, 2022.**

ORANO CANADA INC.

[REDACTED]

Principal [REDACTED]



CHUBB INSURANCE COMPANY OF CANADA

[REDACTED]
Attorney-in-Fact





The Bank of Nova Scotia

Trade Services Centre
2nd Floor, 1 St. Clair Avenue East
Toronto, Ontario M4T 1Z3
Tel: 1-888-722-3867
Fax: 416-866-4286
SWIFT: NOSCCATTPG

**Irrevocable
Standby Letter of Credit
No. [REDACTED]**

Amendment no. 3
Dated March 16, 2022

Beneficiary:
The Government of Saskatchewan as
represented by the Ministry of the
Environment, 102-112 Research Drive
Saskatoon, SK S7N 3R3, Canada

Applicant:
Denison Mines Inc.,
40 University Avenue,
Suite 1100,
Toronto, M5J 1T1 Canada
Ref: 47472-57

We amend our Standby Letter of Credit subject to the following terms and conditions. This amendment forms an integral part of the original instrument. All other terms and conditions remain unchanged.

Amended Terms:

The amount of the Standby Letter of Credit is decreased by: CAD 1,114,153.00 to CAD 22,972,050.00

Unless otherwise instructed herein, all correspondence and enquiries regarding this transaction should be directed to our Customer Service Centre at the above address, telephone: 1-888-722-3867. Please indicate our reference number in all your correspondence or telephone enquiries.

Your consent to this amendment is required. Please immediately forward such written consent to The Bank of Nova Scotia, Trade Services Centre, 2nd Floor, 1 St. Clair Avenue East, Toronto, Ontario M4T 1Z3 quoting our reference number.

Regards,

[REDACTED]

[REDACTED]

Authorised Signature(s)

[REDACTED]



The Bank of Nova Scotia

Trade Service Centre
61 Front Street West, 4th Floor
Toronto, Ontario, M5H 1H1
Tel: 416-847-6250
Fax: 416-866-4286
SWIFT: NOSCCATTPG

**Irrevocable
Standby Letter of Credit
No. [REDACTED]**

Amendment no. 2
Dated May 30, 2016

Beneficiary:
GOVERNMENT OF SASKATCHEWAN
x Canada

Applicant:
Denison Mines Inc.,
595 Bay Street,
Suite 402,
Toronto, M5G 2C2 Canada

Ref: 47472-57

We amend our Standby Letter of Credit subject to the following terms and conditions. This amendment forms an integral part of the original instrument. All other terms and conditions remain unchanged.

Amended Terms:

The amount of the Standby Letter of Credit is increased by: CAD 14,448,594.48 to CAD 24,086,203.00

Applicant address amended to read as:
40 University Avenue, Suite 1100,
Toronto, ON M5J 1T1

Beneficiary name and address amended to read as:
The Government of Saskatchewan as represented by the Ministry of the Environment
102 - 112 Research Drive, Saskatoon, SK S7N 3R3
Attn: Manager - Uranium and Northern Operations, Environmental Protection Branch.

This amendment is effective from May 31, 2016

All other terms and conditions remain unchanged

4
8

[REDACTED]



The Bank of Nova Scotia

Unless otherwise instructed herein, all correspondence and enquiries regarding this transaction should be directed to our Customer Service Centre at the above address, telephone: 416-847-6250. Please indicate our reference number in all your correspondence or telephone enquiries.

Regards



Authorized Signature(s)



ORIGINAL



ONTARIO INTL TRADE
SERVICES,
1 FRONT STREET WEST, 4TH FLOOR,
TORONTO, ONTARIO, CANADA M5H 1H1 TEL. NO.: 416-847-6257

34

DATE: DECEMBER 22, 2009

AMENDMENT TO IRREVOCABLE
STANDBY LETTER OF CREDIT NO.

DATED : APRIL 25, 2006
AMOUNT: CAD 7,875,000.00
AMENDMENT NUMBER: 1

APPLICANT:
DENISON MINES INC.
595 BAY STREET
SUITE 402, TORONTO
ONT. M5G 2C2

BENEFICIARY:
SASKATCHEWAN ENVIRONMENT
BOX 3003, MCINTOSH MALL,
PRINCE ALBERT,
SK. S6V 6G1

THIS AMENDMENT IS TO BE CONSIDERED AS
PART OF THE ABOVE STANDBY LETTER OF
CREDIT AND MUST BE ATTACHED THERETO.

DEAR SIR(S) :

THE ABOVE MENTIONED CREDIT IS AMENDED AS FOLLOWS:
THE AMOUNT OF THIS CREDIT HAS BEEN INCREASED BY CAD 1,762,608.52
THE AMOUNT OF THIS CREDIT IS AMENDED TO: CAD 9,637,608.52

THE BENEFICIARY PARTY HAS BEEN AMENDED:
GOVERNMENT OF SASKATCHEWAN
ENVIRONMENTAL PROTECTION BRANCH
SASKATCHEWAN MINISTRY OF ENVIRONMENT
1112 RESEARCH DRIVE, SASKATOON, SK S7K 2H6

THIS AMENDMENT IS EFFECTIVE DECEMBER 31, 2009.

ALL OTHER TERMS AND CONDITIONS UNCHANGED.

YOURS TRULY,

AUTHORIZED SIGNATURE/SIGNATAIRE AUTORISÉ

ISSUING BANK NOTE: RETAIN IF ISSUED BY BRIEF CABLE: FULL CABLE: SW
(NOTE À LA BANQUE ÉMETTRICE : À CONSERVER SI AVIS BRIEF/COMPLÉT ÉMIS PAR CABLE/SW)

1 - ORIGINAL
2 - CUSTOMER/CLIENT

3 - ADVISING BANK/BANQUE NOTIFICATRICE
4 - BRANCH/SUCCURSALE

ONTARIO INTL TRADE SERVICES,
61 FRONT STREET WEST, 4TH FLOOR,
TORONTO, ONTARIO, CANADA M5H 1H1 TEL. NO.: 416-866-6717

DATE OF ISSUE: APRIL 25, 2006

IRREVOCABLE STANDBY LETTER OF CREDIT
NO: [REDACTED]
AMOUNT: NOT EXCEEDING CAD 7,875,000.00
DATE OF EXPIRY: MARCH 31, 2007

$7,875,000 \times 0.25\% = 19,687.50$
COMMISSION CHG'D
ANNUALLY
(EACH AFFL)

TO:
SASKATCHEWAN ENVIRONMENT
BOX 3003, MCINTOSH MALL,
PRINCE ALBERT,
SK S6V 6G1

APPLICANT:
DENISON MINES INC.
595 BAY STREET
SUITE 402, TORONTO
ONT. M5G 2C2

DEAR SIR(S) :

ON BEHALF OF DENISON MINES INC., WE HEREBY ISSUE IN YOUR FAVOUR OUR IRREVOCABLE STANDBY LETTER OF CREDIT IN THE AMOUNT OF CANADIAN DOLLARS SEVEN MILLION EIGHT HUNDRED SEVENTY FIVE THOUSAND ONLY (CAD7,875,000.00) INCLUDING INTEREST, COSTS AND ACCESSORIES.

A PAYMENT UNDER THIS STANDBY LETTER OF CREDIT SHALL BE MADE ON OR BEFORE THE EXPIRY DATE UPON YOU PRESENTING THIS STANDBY LETTER OF CREDIT ACCOMPANIED BY:

1) A DEMAND IN WRITING PURPORTEDLY SIGNED BY THE PERSON WHO HAS BEEN DULY AUTHORIZED TO SIGN ON YOUR BEHALF.

2) A BENEFICIARY'S SIGNED CERTIFICATE STATING THAT EITHER:

A) DENISON MINES INC. HAS FAILED TO FULFILL ITS OBLIGATIONS WITH RESPECT TO DECOMMISSIONING OF THE MCCLEAN LAKE URANIUM MINING OPERATION RESULTING FROM, OR UNDER, THE URANIUM AND THORIUM MINING REGULATIONS (SOR/88-243), OR THE URANIUM AND THORIUM MINING REGULATIONS, AMENDMENT (SOR/94-653), OR UPON THE OCCURRENCE OF A DEFAULT WITHIN THE MEANING OF SECTION 19(1) OF THE MINERAL INDUSTRY ENVIRONMENTAL PROTECTION REGULATIONS, 1996 R.S.S. CE-10.2 REG 7, OR

3) THE BANK HAS NOTIFIED THE APPLICANT AND BENEFICIARY THAT THE BANK HAS ELECTED NOT TO CONSIDER THIS LETTER OF CREDIT RENEWED FOR AN ADDITIONAL ONE YEAR PERIOD AND THE APPLICANT HAS FAILED TO PROVIDE, ON OR BEFORE THE DATE THAT IS 30 DAYS PRIOR TO THE EXPIRY DATE, A RENEWAL LETTER OF CREDIT ACCEPTABLE TO THE BENEFICIARY, ACTING REASONABLY.

[REDACTED SIGNATURE]

AUTHORIZED SIGNATURE/SIGNATAIRE AUTORISÉ

[REDACTED SIGNATURE]

AUTHORIZED SIGNATURE/SIGNATAIRE AUTORISÉ

IN THE EVENT THAT THE NUCLEAR SAFETY AND CONTROL ACT COMES INTO FORCE DURING THE TERM OF THIS STANDBY LETTER OF CREDIT, ANY REFERENCE TO THE ATOMIC ENERGY CONTROL BOARD (AECB) SHALL READ AS A REFERENCE TO THE CANADIAN NUCLEAR SAFETY COMMISSION AND ANY REFERENCE TO THE URANIUM AND THORIUM MINING REGULATIONS SHALL BE READ AS A REFERENCE TO THE NUCLEAR SAFETY AND CONTROL ACT.

THIS STANDBY LETTER OF CREDIT SHALL REMAIN IN EFFECT UP TO BUT NOT LATER THAN MARCH 31, 2007 (THE EXPIRY DATE), UPON RECEIPT OF THE SAID DOCUMENTS SET FORTH IN PARAGRAPH 1 AND 2 ABOVE ON OR BEFORE THE EXPIRY DATE, THE BANK SHALL PAY TO YOU THE AMOUNT STATED UNDER THE SAID DEMAND TO BE PAYABLE TO YOU WITHOUT ENQUIRING WHETHER YOU HAVE A RIGHT TO SUCH AMOUNT AS BETWEEN YOURSELF AND THE APPLICANT PROVIDING SUCH AMOUNT, TOGETHER WITH OTHER AMOUNTS PAID TO YOU UNDER THIS STANDBY LETTER OF CREDIT, IF ANY, DO NOT EXCEED THE AGGREGATE AMOUNT OF THE STANDBY LETTER OF CREDIT.

IT IS A CONDITION OF THIS STANDBY LETTER OF CREDIT THAT IT SHALL BE DEEMED TO BE AUTOMATICALLY EXTENDED WITHOUT AMENDMENT FOR ONE YEAR FROM THE PRESENT OR ANY FUTURE EXPIRATION DATE HEREOF, UNLESS AT LEAST NINETY (90) DAYS PRIOR TO ANY SUCH DATE, WE SHALL NOTIFY YOU IN WRITING BY REGISTERED MAIL OR COURIER THAT WE ELECT NOT TO CONSIDER THIS STANDBY LETTER OF CREDIT RENEWED FOR ANY SUCH ADDITIONAL PERIOD.

PARTIAL DRAWINGS ARE PERMITTED.

UNLESS OTHERWISE SPECIFIED, THIS CREDIT IS SUBJECT TO THE UNIFORM CUSTOMS AND PRACTICE FOR DOCUMENTARY CREDITS (1993 REVISION) INTERNATIONAL CHAMBER OF COMMERCE PUBLICATION NO. 500.

THIS STANDBY LETTER OF CREDIT IS GOVERNED BY THE LAWS OF THE PROVINCE OF SASKATCHEWAN AND THE COURTS OF THAT PROVINCE SHALL HAVE EXCLUSIVE JURISDICTION ON ALL MATTERS RELATING TO THIS STANDBY LETTER OF CREDIT AND ALL RECOURSES RESULTING THEREFROM.

WE ENGAGE TO HONOUR PRESENTATIONS SUBMITTED WITHIN THE TERMS AND CONDITIONS INDICATED ABOVE.

YOURS VERY TRULY,

[REDACTED SIGNATURE]

AUTHORIZED SIGNATURE/SIGNATAIRE AUTORISÉ

[REDACTED SIGNATURE]

AUTHORIZED SIGNATURE/SIGNATAIRE AUTORISÉ



ISSUING BANK:
BNP PARIBAS
155 WELLINGTON STREET WEST
SUITE 3110
RBC CENTER
TORONTO, (ONTARIO) M5V 3H1

IRREVOCABLE LETTER OF GUARANTEE NO.
[REDACTED]

ISSUING DATE: NOVEMBER 02, 2020

EXPIRY DATE: MARCH 01, 2021
(SUBJECT TO AUTO EXTENSION TERMS)

APPLICANT:
GOVERNMENT OF SASKATCHEWAN
SASKATCHEWAN MINISTRY OF
ENVIRONMENT INDUSTRIAL, URANIUM
AND HARDROCK MINING UNIT
112 RESEARCH DRIVE
(SASKATOON) SASKATCHEWAN S7K 2H6
CANADA

BENEFICIARY:
ORANO CANADA INC.
100-833, 45TH STREET WEST
SASKATOON (SASKATCHEWAN) S7L 5X2
CANADA

AMENDMENT NO.07

THE ABOVE-MENTIONED LETTER OF GUARANTEE THAT WE HAVE ISSUED IN YOUR FAVOR IS AMENDED BY THE PRESENT, AS FOLLOWS:

THE APPLICANT'S NAME AND ADDRESS THAT WAS SPECIFIED ARE CHANGED TO READ:

'ORANO CANADA INC.
100-833, 45TH STREET WEST
SASKATOON (SASKATCHEWAN) S7L 5X2'

ALL THE OTHER TERMS AND CONDITIONS OF OUR LETTER OF GUARANTEE WHICH ARE NOT HEREIN AMENDED REMAIN THE SAME.

BNP PARIBAS

BY: [REDACTED]

AUTHORIZED SIGNATURE

[REDACTED]
BY: [REDACTED]

AUTHORIZE SIGNATURE

ORIGIN ID: YJTB (514) 285-6100
EMILIE PODCORSKI

SHIP DATE: 02NOV20
ACTWGT: 0.50 LB
C.A.D. 1048629144N/E14280

2001 ROBERT-BOURASSA BLVD.
SUITE 600
MONTREAL, PQ H3A2A6
CANADA QA

BILL SENDER

TO

ORANO CANADA INC
100-833 45TH STREET WEST

SASKATOON SK S7L5X2

(CA)

(306) 243-5553
NV F4C411
REF: 990004

DEPT F4C411

56B351D8/766

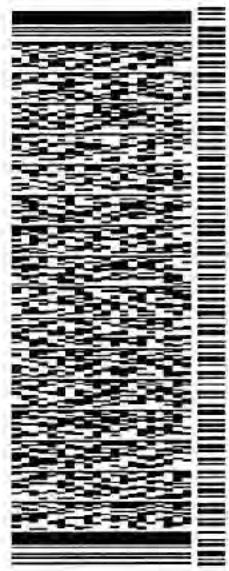

TRK# 7719 6458 6842
0451

TUE - 03 NOV A2
PRIORITY OVERNIGHT

7B YXEA

S7L 5X2
SK-CA YXC



After printing this label:

CONSIGNEE COPY - PLEASE PLACE IN FRONT OF POUCH

- 1. Fold the printed page along the horizontal line.
- 2. Place label in shipping pouch and affix it to your shipment.

Warning: Use only the printed original label for shipping. Using a photocopy of this label for shipping purposes is fraudulent and could result in additional billing charges, along with the cancellation of your FedEx account number.

DEFINITIONS. On this Air Waybill, "we", "our", "us", and "FedEx" refer to Federal Express Canada Ltd., its principals, subsidiaries, branches and affiliates and their respective employees, agents, and independent contractors. The terms "you" and "your" include the shipper, sender, recipient/consignee, and their respective employees, principals, agents and independent contractors. The term "package" means any container or envelope that is accepted by us for delivery, including any such items tendered by you utilizing our automated systems, meters, manifests or waybills. The term "shipment" means all packages which are tendered to and accepted by us on a single Air Waybill. ROAD TRANSPORT NOTICE. Any carriage of your shipment by road may be subject to Federal and Provincial laws, regulations, orders or requirements which may govern and serve to limit our liability for damage, loss, delay, shortage, mis-delivery, nondelivery, misinformation or failure to provide information in connection with your shipment. LIMITATION OF LIABILITY. If not governed by Federal or Provincial laws, regulations, orders, or requirements as described above, FedEx's maximum liability for damage, loss, delay, shortage, mis-delivery, nondelivery, misinformation or failure to provide information in connection with your shipment even if caused by our negligence or gross negligence, is limited by this Agreement to the amount of actual damages or CDN \$100 per shipment, whichever is less, unless you declare in advance a higher value for carriage as described below, and pay any applicable supplementary charge. FedEx does not provide cargo liability or all-risk insurance, but you may pay an additional charge for each additional CDN \$100 of declared value for carriage. If a higher value for carriage is declared and the additional charge is paid, FedEx's maximum liability will be the lesser of the declared value for carriage or your actual damages. DECLARED VALUE LIMITS. Shipments containing items of extraordinary value are limited to a maximum declared value for carriage of CDN \$500. The maximum declared value we allow for carriage per air waybill for each FedEx Letter or FedEx Pak is CDN \$100. Please check the current Worldwide Service Guide and any applicable tariff for further explanation of the declared value limits. If you send more than one package on this Air Waybill, the declared value for carriage of each package will be determined by dividing the total declared value for carriage by the number of packages in the shipment. LIABILITIES NOT ASSUMED. IN ANY EVENT, FEDEX WON'T BE LIABLE FOR ANY DAMAGES, WHETHER DIRECT, INDIRECT, INCIDENTAL, SPECIAL OR CONSEQUENTIAL, IN EXCESS OF THE DECLARED VALUE FOR CARRIAGE (INCLUDING BUT NOT LIMITED TO LOSS OF INCOME OR PROFITS) OR THE ACTUAL VALUE OF THE SHIPMENT, IF LOWER, WHETHER OR NOT FEDEX HAD ANY KNOWLEDGE THAT SUCH DAMAGES MIGHT BE INCURRED. FedEx won't be liable for your acts or omissions, including but not limited to, incorrect declaration of the shipment, improper or insufficient packing, securing, marking or addressing of the shipment, or for the acts or omissions of the recipient or anyone else with an interest in the shipment. FedEx won't be liable for damage, loss, delay, shortage, mis-delivery, nondelivery, misinformation or failure to provide information in connection with shipments of cash, currency or other prohibited items. Also, FedEx won't be liable if you or the recipient violate any of the terms of this Agreement. FedEx won't be liable for loss, damage, delay, shortage, mis-delivery, nondelivery, misinformation or failure to provide information in connection with your shipment caused by events FedEx cannot control, including but not limited to, acts of God, perils of the air, weather conditions, acts of public enemies, war, strikes, civil commotions, or acts or omissions of public authorities (including customs and health officials) with actual or apparent authority. You should contact an insurance agent or broker if insurance coverage is desired. We do not provide insurance coverage of any kind. NO WARRANTIES. We make no warranties, express or implied. CLAIM FOR LOSS, DAMAGE OR DELAY. ALL CLAIMS MUST BE MADE IN WRITING AND WITHIN STRICT TIME LIMITS. SEE OUR CURRENT WORLDWIDE SERVICE GUIDE AND ANY APPLICABLE TARIFF FOR DETAILS. We must receive your written notice of a claim for damage or delay, including perishable and spoilage damage claims due to late or delayed delivery, within 21 days after we deliver your shipment and in the case of loss, shortage, mis-delivery, nondelivery, misinformation or failure to provide information, within 90 days after we accept the shipment for carriage. The right to claim damages against us shall be extinguished unless an action is brought within two years from the date of delivery of the shipment or from the date on which the shipment should have been delivered or from the date on which the carriage stopped. Within 90 days after you have notified us of your claim, it must be documented by sending us all relevant information regarding your claim. FedEx is not obligated to act on any claim until all transportation charges have been paid. The claim amount may not be deducted from these charges. If the recipient accepts the shipment without noting any damage on the delivery record, FedEx will assume the shipment was delivered in good condition. In order for us to consider a claim for damage, the contents, original shipping carton and packing must be made available to us for inspection at the delivery location and you must retain all such items until the claim is concluded. RESPONSIBILITY FOR PAYMENT. Even if you give us different payment instructions, you, the shipper, will always be primarily responsible for all charges, including transportation charges, and all duties, assessments, governmental penalties and fines, taxes, and FedEx's legal fees and costs related to shipments tendered under this Agreement. You also will be responsible for any costs FedEx may incur in returning your shipments to you or warehousing them pending disposition. MANDATORY LAW. Insofar as any provisions contained or referred to in this Agreement may be contrary to any applicable laws, government regulations, orders or requirements, such other provisions shall remain in effect as a part of this Agreement to the extent that they are not overridden. The invalidity or unenforceability of any provisions of this Agreement shall not affect any other part hereof. The parties expressly agree that this Agreement be drawn up in the English language. FEDERAL EXPRESS CANADA LTD., Head Office, 5985 Explorer Drive, Mississauga, ON L4W 5K6.

To : **BNP PARIBAS (Canada)**

Date : **FEBRUARY 9, 2010**

Branch : _____

REQUEST RELATING TO A LETTER OF GUARANTEE OR A STAND BY LETTER OF CREDIT

ISSUANCE: AMENDMENT: RENEWAL:

Kindly issue/amend or renew a letter of guarantee or stand-by letter of credit in accordance with the following:

Reference No. : _____ Issuance Date : _____
 (Indicate if refers to an amendment or a renewal) Effective Date : _____
 (If it differs from the issuance date) Expiry Date : _____

Amount : **CAD 166,664.78** **MARCH 1, 2011 WITH AN AUTOMATIC RENEWAL CLAUSE UNLESS 90 DAYS NOTICE.**

Beneficiary (name and address) : **GOVERNMENT OF SASKATCHEWAN
SASKATCHEWAN MINISTRY OF ENVIRONMENT
INDUSTRIAL, URANIUM AND HARDROCK
MINING UNIT
112 RESEARCH DRIVE
SASKATOON (SASKATCHEWAN) S7K 2H6**

Applicant (name and address) : **AREVA RESOURCES CANADA INC.
817-825, 45TH STREET WEST
P.O. BOX 8204
SASKATOON (SASKATCHEWAN) S7K 3X5**

Transaction or agreement which is the object of the guarantee :

Text of the guarantee applicable to the transaction (Check the appropriate square)

- Standard text
- Non standard text
- Salary Bond
- Bid Bond
- Performance bond
- Retention money bond
- Guarantee for repayment of advances
- Stand-by letter of credit
- Amendment or renewal
- Counter-guarantee

AGREEMENT RELATING TO THE ISSUANCE/AMENDMENT OR RENEWAL OF A LETTER OF GUARANTEE OR OF A STAND-BY LETTER OF CREDIT

In consideration for your accepting to issue/amend or renew a letter of guarantee or stand-by letter of credit in accordance with this request, we hereby agree to reimburse you on demand, including interest at the agreed rate applicable to overdrafts in our accounts, any amount which you may be called upon to pay pursuant to this letter of guarantee or stand-by letter of credit, interest being computed from the day you make payment.

You are authorized to honor this letter of guarantee or stand-by letter of credit without any prior notice to ourselves and without any inquiry as to the validity of a demand for payment thereunder.

We shall pay the fees and costs stated in our commitment letter with the Bank as well as the related costs of any third-party bank which may intervene at your request. Furthermore, and subject to any other prior agreement, we shall also pay any legal fees resulting from the issuance, amendment or renewal of non-standard letters of guarantee or stand-by letters of credit, it being understood that any non-standard letter must be reviewed, at our cost, by the Bank's legal counsel at the hourly rate then prevailing.

We authorize you to rely on the present request sent to the Bank by electronic mail or by teletype and appearing to be signed by us or one of our representatives; we acknowledge to be bound by the text of this request transmitted to the Bank.

In the event that a letter of guarantee or stand-by letter of credit is issued by you and that at our request it is without a calendar expiry date or in the event that it is issued in favour of a foreign beneficiary and that such beneficiary does not acknowledge, for any reason whatsoever including their legislation, being bound by the stated expiry date unless a discharge from the foreign beneficiary is obtained, we undertake to (i) reimburse you on demand or indemnify you against any damages you could incur by virtue of this letter of guarantee or stand-by letter of credit which shall remain valid until such time as you are released from your liability by virtue of this letter of guarantee or stand-by letter of credit by a discharge and (ii) to pay the commission owed by us to you according to our agreement with the Bank.

We agree to hold you harmless from any damages which you may incur and we agree to pay all costs that you may be called upon to pay pursuant to this letter of guarantee or stand-by letter of credit or pursuant to litigation resulting therefrom. We shall take all steps necessary to ensure that at the expiry of the letter of guarantee or stand-by letter of credit, the original letter shall be returned to you by the Beneficiary.

All amounts owed to you pursuant to this Agreement may be debited from our account.

This Agreement also applies to any renewal or amendment of this letter of guarantee or stand-by letter of credit.

If the request relates to the issuance/amendment or renewal of a counter-guarantee, in every paragraph in the text above where we refer to a letter of guarantee, you should read counter-guarantee.

Executed at Saskatoon, this 11th day of Feb 20 10

Applicant's signatures

FOR THE BANK'S USE ONLY

Guarantee debit account : _____	Guarantee commitment account : _____
Amount of guarantee : _____ \$	Issuance date : _____
Fees and commissions debit account : _____	Reference : _____
Rate of commissions : _____ %	Expiry : _____
Rate of commissions for third-party bank : _____ %	Amount : _____ \$
Fees : standard <input type="checkbox"/> or <input type="checkbox"/> other additional fees (specify) : _____	Amount : _____ \$
Commissions for letter of intent : _____	
Commissions : <input type="checkbox"/> Annual <input type="checkbox"/> Semi-annual <input type="checkbox"/> Quarterly <input type="checkbox"/> Expiry	



The Bank of Nova Scotia

Trade Service Centre
61 Front Street West, 4th Floor
Toronto, Ontario, M5H 1H1
Tel: 416-847-6250
Fax: 416-866-4286
SWIFT: NOSCCATTPG

**Irrevocable
Standby Letter of Credit
No. [REDACTED]**

Amendment no. 2
Dated May 30, 2016

Beneficiary:
GOVERNMENT OF SASKATCHEWAN
x Canada

Applicant:
Denison Mines Inc.,
595 Bay Street,
Suite 402,
Toronto, M5G 2C2 Canada

Ref: 47472-58

We amend our Standby Letter of Credit subject to the following terms and conditions. This amendment forms an integral part of the original instrument. All other terms and conditions remain unchanged.

Amended Terms:

The amount of the Standby Letter of Credit is decreased by: CAD 12,528.76 to CAD 48,127.00

Applicant address amended to read as:
40 University Avenue, Suite 1100,
Toronto, ON M5J 1T1

Beneficiary name and address amended to read as:
The Government of Saskatchewan as represented by the Ministry of the Environment
102 - 112 Research Drive, Saskatoon, SK S7N 3R3
Attn: Manager - Uranium and Northern Operations, Environmental Protection Branch.

This amendment is effective from May 31, 2016

All other terms and conditions remain unchanged





The Bank of Nova Scotia

Unless otherwise instructed herein, all correspondence and enquiries regarding this transaction should be directed to our Customer Service Centre at the above address, telephone: 416-847-6250. Please indicate our reference number in all your correspondence or telephone enquiries.

Regards,

[Redacted signature]

[Redacted signature]

Authorised Signature(s)

ORIGINAL

[Redacted]

ONTARIO INTL TRADE
SERVICES,
1 FRONT STREET WEST, 4TH FLOOR,
TORONTO, ONTARIO, CANADA M5H 1H1 TEL. NO.: 416-847-6257

PAGE: 1
SAM STAMEND

DATE: DECEMBER 22, 2009

AMENDMENT TO IRREVOCABLE
STANDBY LETTER OF CREDIT NO.

[REDACTED]
DATED : APRIL 26, 2006
AMOUNT: CAD 188,775.00
AMENDMENT NUMBER: 1

APPLICANT:
DENISON MINES INC.
595 BAY STREET
SUITE 402, TORONTO
ONT. M5G 2C2

BENEFICIARY:
SASKATCHEWAN ENVIRONMENT
BOX 3003, MCINTOSH MALL,
PRINCE ALBERT,
SK. S6V 6G1

THIS AMENDMENT IS TO BE CONSIDERED AS
PART OF THE ABOVE STANDBY LETTER OF
CREDIT AND MUST BE ATTACHED THERETO.

DEAR SIR(S) :

THE ABOVE MENTIONED CREDIT IS AMENDED AS FOLLOWS:
THE AMOUNT OF THIS CREDIT HAS BEEN DECREASED BY CAD 128,119.24
THE AMOUNT OF THIS CREDIT IS AMENDED TO: CAD 60,655.76

THE BENEFICIARY PARTY HAS BEEN AMENDED:
GOVERNMENT OF SASKATCHEWAN
ENVIRONMENTAL PROTECTION BRANCH
SASKATCHEWAN MINISTRY OF ENVIRONMENT
112 RESEARCH DRIVE, SASKATOON, SK S7K 2H6

THIS AMENDMENT IS EFFECTIVE DECEMBER 31, 2009.

THE BENEFICIARY IS REQUESTED TO SIGNIFY THEIR ACCEPTANCE OR NON-ACCEPTANCE OF
THIS AMENDMENT BY SIGNING AND RETURNING A COPY OF THIS AMENDMENT

ALL OTHER TERMS AND CONDITIONS UNCHANGED.

YOURS TRULY,

[REDACTED SIGNATURE]

[REDACTED SIGNATURE]

AUTHORIZED SIGNATURE/SIGNATAIRE AUTORISÉ

AUTHORIZED SIGNATURE/SIGNATAIRE AUTORISÉ

THE BANK OF NOVA SCOTIA/LA BANQUE DE NOUVELLE-ÉCOSSE

(ISSUING BANK NOTE: RETAIN IF ISSUED BY BRIEF CABLE/FULL CABLE/SWIFT)

- 1 - ORIGINAL
- 2 - CUSTOMER/CLIENT
- 3 - ADVISING BANK/BANQUE NOTIFICATRICE
- 4 - BRANCH/SUCCURSALE

(NOTE À LA BANQUE ÉMETTRICE : À CONSERVER SI AVIS BREF/COMPLET ÉMIS PAR CABLE/SWIFT)

ONTARIO INTL TRADE SERVICES,
61 FRONT STREET WEST, 4TH FLOOR,
TORONTO, ONTARIO, CANADA M5H 1H1 TEL. NO.: 416-866-6717

PAGE: 1
SLO NSTDISLC

DATE OF ISSUE: APRIL 26, 2006

IRREVOCABLE STANDBY LETTER OF CREDIT

NO: [REDACTED]

AMOUNT: NOT EXCEEDING CAD 188,775.00

DATE OF EXPIRY: MARCH 31, 2007

$188,775 \times 0.25\% = 471.94$

COMMISSION CHG'D
ANNUALLY
(EACH APRIL)

TO:
SASKATCHEWAN ENVIRONMENT
BOX 3003, MCINTOSH MALL,
PRINCE ALBERT,
SK, S6V 6G1

APPLICANT:
DENISON MINES INC.
595 BAY STREET
SUITE 402, TORONTO
ONT. M5G 2C2

DEAR SIR(S) :

ON BEHALF OF DENISON MINES INC., WE HEREBY ISSUE IN YOUR FAVOUR OUR IRREVOCABLE STANDBY LETTER OF CREDIT IN THE AMOUNT OF CANADIAN DOLLARS ONE HUNDRED EIGHTY EIGHT THOUSAND SEVEN HUNDRED SEVENTY FIVE ONLY (CAD188,775.00) INCLUDING INTEREST, COSTS AND ACCESSORIES.

A PAYMENT UNDER THIS STANDBY LETTER OF CREDIT SHALL BE MADE ON OR BEFORE THE EXPIRY DATE UPON YOU PRESENTING THIS STANDBY LETTER OF CREDIT ACCOMPANIED BY:

1) A DEMAND IN WRITING PURPORTEDLY SIGNED BY THE PERSON WHO HAS BEEN DULY AUTHORIZED TO SIGN ON YOUR BEHALF.

2) A BENEFICIARY'S SIGNED CERTIFICATE STATING THAT EITHER:

A) DENISON MINES INC. HAS FAILED TO FULFILL ITS OBLIGATIONS WITH RESPECT TO DECOMMISSIONING OF THE MIDWEST PROJECT RESULTING FROM, OR UNDER, THE URANIUM AND THORIUM MINING REGULATIONS (SOR/88-243), OR THE URANIUM AND THORIUM MINING REGULATIONS, AMENDMENT (SOR/94-653), OR UPON THE OCCURRENCE OF A DEFAULT WITHIN THE MEANING OF SECTION 19(1) OF THE MINERAL INDUSTRY ENVIRONMENTAL PROTECTION REGULATIONS, 1996 R.S.S. CE-10.2 REG 7, OR

B) THE BANK HAS NOTIFIED THE APPLICANT AND BENEFICIARY THAT THE BANK HAS ELECTED NOT TO CONSIDER THIS LETTER OF CREDIT RENEWED FOR AN ADDITIONAL ONE YEAR PERIOD, AND THE APPLICANT HAS FAILED TO PROVIDE, ON OR BEFORE THE DATE THAT IS 30 DAYS PRIOR TO THE EXPIRY DATE, A RENEWAL LETTER OF CREDIT ACCEPTABLE TO THE BENEFICIARY, ACTING REASONABLY.

[REDACTED SIGNATURE]

[REDACTED SIGNATURE]

AUTHORIZED SIGNATURE/SIGNATAIRE AUTORISÉ

AUTHORIZED SIGNATURE/SIGNATAIRE AUTORISÉ

THE BANK OF NOVA SCOTIA/LA BANQUE DE NOUVELLE-ÉCOSSE

(ISSUING BANK NOTE: RETAIN IF ISSUED BY BRIEF CABLE/FULL CABLE/SWIFT)
(NOTE À LA BANQUE ÉMETTRICE : À CONSERVER SI AVIS BREF/COMPLÉT ÉMIS PAR CABLE/SWIFT)

381 (7/99)
ORIGINAL
CUSTOMER/CLIENT

3 - ADVISING BANK/BANQUE NOTIFICATRICE
4 - BRANCH/SUCCURSALE



IN THE EVENT THAT THE NUCLEAR SAFETY AND CONTROL ACT COMES INTO FORCE DURING THE TERM OF THIS STANDBY LETTER OF CREDIT, ANY REFERENCE TO THE ATOMIC ENERGY CONTROL BOARD (AECB) SHALL READ AS A REFERENCE TO THE CANADIAN NUCLEAR SAFETY COMMISSION AND ANY REFERENCE TO THE URANIUM AND THORIUM MINING REGULATIONS SHALL BE READ AS A REFERENCE TO THE NUCLEAR SAFETY AND CONTROL ACT.

THIS STANDBY LETTER OF CREDIT SHALL REMAIN IN EFFECT UP TO BUT NOT LATER THAN MARCH 31, 2007 (THE EXPIRY DATE), UPON RECEIPT OF THE SAID DOCUMENTS SET FORTH IN PARAGRAPH 1 AND 2 ABOVE ON OR BEFORE THE EXPIRY DATE, THE BANK SHALL PAY TO YOU THE AMOUNT STATED UNDER THE SAID DEMAND TO BE PAYABLE TO YOU WITHOUT ENQUIRING WHETHER YOU HAVE A RIGHT TO SUCH AMOUNT AS BETWEEN YOURSELF AND THE APPLICANT, PROVIDING SUCH AMOUNT, TOGETHER WITH OTHER AMOUNTS PAID TO YOU UNDER THIS STANDBY LETTER OF CREDIT, IF ANY, DO NOT EXCEED THE AGGREGATE AMOUNT OF THE STANDBY LETTER OF CREDIT.

IT IS A CONDITION OF THIS STANDBY LETTER OF CREDIT THAT IT SHALL BE DEEMED TO BE AUTOMATICALLY EXTENDED WITHOUT AMENDMENT FOR ONE YEAR FROM THE PRESENT OR ANY FUTURE EXPIRATION DATE HEREOF, UNLESS AT LEAST NINETY (90) DAYS PRIOR TO ANY SUCH DATE, WE SHALL NOTIFY YOU IN WRITING BY REGISTERED MAIL OR COURIER THAT WE ELECT NOT TO CONSIDER THIS STANDBY LETTER OF CREDIT RENEWED FOR ANY SUCH ADDITIONAL PERIOD.

PARTIAL DRAWINGS ARE PERMITTED.

UNLESS OTHERWISE SPECIFIED, THIS CREDIT IS SUBJECT TO THE UNIFORM CUSTOMS AND PRACTICE FOR DOCUMENTARY CREDITS (1993 REVISION) INTERNATIONAL CHAMBER OF COMMERCE PUBLICATION NO. 500.

THIS STANDBY LETTER OF CREDIT IS GOVERNED BY THE LAWS OF THE PROVINCE OF SASKATCHEWAN AND THE COURTS OF THAT PROVINCE SHALL HAVE EXCLUSIVE JURISDICTION ON ALL MATTERS RELATING TO THIS STANDBY LETTER OF CREDIT AND ALL RECOURSES RESULTING THEREFROM.

WE ENGAGE TO HONOUR PRESENTATIONS SUBMITTED WITHIN THE TERMS AND CONDITIONS INDICATED ABOVE.

YOURS VERY TRULY,



AUTHORIZED SIGNATURE/SIGNATAIRE AUTORISÉ

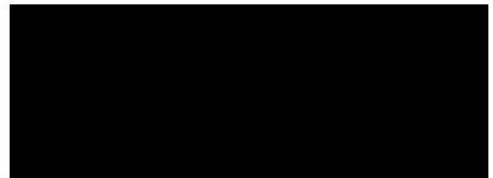

AUTHORIZED SIGNATURE/SIGNATAIRE AUTOBISÉ

Appendix E: CSA N294-19 Concordance Table

The following table provides a cross reference to the suggested information for inclusion in a PDP, as outlined in the Canadian Standards Association document Decommissioning of Facilities Containing Nuclear Substances, Annex A (informative) – Preliminary Decommissioning Plan (CSA 2019), to the information included in this PDP.

Table E1.1 CSA N294.19 Concordance Table

Canada Standards Association N294-19 Annex A(informative) - Preliminary decommissioning plan	McClellan Lake Operation PDP Reference Location
A PDP may include the following:	-
(a) a description of the location of the facility, including	Section 2.1
(i) a map of the facility and its specifications;	Appendix A, Figure 2: McClellan Lake Operation; Section 2.5.6 – Reference to the McClellan Lake Operation Facility Description Manual (Orano 2022)
(ii) geographic information;	Appendix A, Figure 1: McClellan Lake Operation Location
(iii) details regarding the surrounding environment;	Section 2.5.6 - Reference to the McClellan Lake Operation, Environmental Performance Technical Information Document (AREVA 2016) for a description of biophysical environment and land uses.
(iv) land uses; and	
(v) illustrations and maps of the facility in relation to the municipality;	Appendix A, Figure 1 Site Location
(b) purpose and description of the facility, including	Section 2.5.6 - Reference to the McClellan Lake Operation Facility Description Manual (Orano 2016a).
(i) primary components and systems;	
(ii) building type and construction, including location of any hazardous building materials (e.g., asbestos, PCBs);	
(iii) building services (e.g., power, heating, ventilation, sewer, water, fire protection);	
(iv) laboratories and other hazardous handling areas;	
(v) type, quantity, and form of radioactive and hazardous materials stored, produced, or used during operation; and	
(vi) design features used to reduce the spread of contamination and facilitate decontamination and dismantling.	
(c) post-operational conditions, including	-
(i) a summary of the shutdown process, including planned removal of stored inventories of hazardous or radioactive materials.	Section 5.1.1
(ii) the predicted nature and extent of contamination remaining in the primary systems and components (in list or table format with reference to applicable illustrations);	Section 5.1.1

Canada Standards Association N294-19 Annex A(informative) - Preliminary decommissioning plan	McClellan Lake Operation PDP Reference Location
(iii) the predicted nature and extent of contamination on floors, walls, work surfaces, ventilation systems, etc.; and	Section 5.1.1
(iv) the identification of any separate planning envelopes;	Section 2.1.1 describes planning envelopes for decommissioning
(v) an overview of the principal hazardous conditions anticipated to exist;	Section 6.1.1, 6.1.2
(d) the decommissioning strategy, including	-
(i) the final end-state objective;	Section 2.3, 2.4, 2.5 5.2.2
(ii) rationale for	-
(1) the decommissioning strategy selected;	Section 5.1.2
(2) interim end states;	Section 5.1.2, 5.5.1
(3) periods of storage with surveillance; and	Section 5.1.2
(4) in-situ decommissioning concepts;	Section 4.2.6, 5.3.5
(iii) the requirements for long-term institutional controls; and	Section 5.4.2
(iv) the assessment of alternative strategies (or a rationale for why alternatives do not exist or do not warrant consideration);	Section 5.0
(e) a decommissioning work plan, including	
(i) A work breakdown schedule;	Section 5.1.2, 5.5.1
(ii) a summary of the main steps for decontamination/disassembly/removal of each of the components and systems (preferably grouped into work packages);	Section 5.1.2, 5.3, 5.5.1
(iii) for each work package, identification of those types of activities that could pose a significant hazard to workers, the public, or the environment;	Section 4.6, 5.1.1
(iv) the role of existing operational standard procedures for radiation protection, hazardous materials handling, industrial safety, and environmental protection in managing hazards;	Section 4.6
(v) specific activities for which additional protection/mitigation procedures will be required at the detailed planning stage;	Section 5.3
(vi) a summary of the final dismantlement of the structures; and	Section 5.1.1, 5.3
(vii) a conceptual schedule showing the approximate year of facility shutdown and the approximate sequencing and duration of the decommissioning work packages and, where relevant, storage periods;	Section 5.5.1
(f) radiological monitoring and survey commitments, including	-

Canada Standards Association N294-19 Annex A(informative) - Preliminary decommissioning plan	McClellan Lake Operation PDP Reference Location
(i) a program for conducting periodic contamination surveys and the recording of contamination events during facility operation;	Section 4.6.3, 4.6.8
(ii) a commitment to conduct detailed post-operation surveys in support of DDP development;	Section 4.6, 5.3,
(iii) a commitment to develop plans and protocols to the AHJ at the planning stage for monitoring	Section 4.6
(1) work hazards during decommissioning;	Section 4.6.4
(2) personnel dosimetry;	Section 4.6.3
(3) environmental emissions and effluents; and	Section 4.6.2
(4) materials, sites, and structures to be cleared from regulatory control;	Section 5.3, 5.4.2
(g) a waste management strategy specifying	-
(i) the approximate quantities and characteristics of radioactive and chemically hazardous wastes expected to arise from the decommissioning (tied to specific work packages, if possible);	Section 5.3, Table B1.3
(ii) the anticipated final disposition of radioactive and chemically hazardous materials; and	Section 5.3
(iii) a commitment to segregate as much material as possible for reuse and recycling;	Section 5.0
(h) a commitment to prepare a DDP for regulatory approval prior to dismantling and demolition;	Section 2.5.3
(i) a commitment to periodically review and update the PDP until a DDP is prepare, in accordance with Clause 6.2.2	Section 2.5.2
(j) the physical state of the facility at	-
(i) the end of operations	Section 5.1, 5.1.1
(ii) the start of decommissioning	Section 5.1.1
(k) the records required for decommissioning, including a description of the facility operational records that will be maintained to periodically update the PDP and prepare the DDP(s);	Section 4.6.8
(l) a public engagement plan, including a public information program and avenues for public participation;	Section 2.5.4
(m) an Indigenous engagement plan as per the requirements and guidance of CNSC Regdoc 3-2-2; and	Section 2.5.4
(n) the cost and a financial guarantee, specifying:	-
(i) an estimate of the total present-value cost of the decommissioning;	Section 6.0
(ii) a reasonable basis for how cost estimates were derived; and	Appendix B

Canada Standards Association N294-19 Annex A(informative) - Preliminary decommissioning plan	McClellan Lake Operation PDP Reference Location
(iii) a description of how the required funds will be provided;	Appendix D

Appendix F: REGDOC-2.11.2 Concordance Table

The following table provides a cross reference to the suggested information for inclusion in a PDP, as outlined in the Canadian Nuclear Safety Commission REGDOC-2.11.2 Decommissioning (CNSC 2021c) to the information included in the financial cost estimate provided as Appendix B.

CNSC REGDOC-2.11.2 Decommissioning	McClean Lake Operation McClean Lake PDP Reference Location
A PDP for nuclear facility with a Class I or a uranium mines and mills licence shall include, as applicable:	-
<ul style="list-style-type: none"> • a description of the location of the facility, including: 	Section 2.1
<ul style="list-style-type: none"> <ul style="list-style-type: none"> ○ a map of the facility and its specifications 	Appendix A: Figures
<ul style="list-style-type: none"> <ul style="list-style-type: none"> ○ geographic information 	Appendix A, Figure 1: McClean Lake Operation Location
<ul style="list-style-type: none"> <ul style="list-style-type: none"> ○ details regarding the surrounding environment 	Section 2.5.6 Reference to McClean Lake Operation, Environmental Performance Technical Information Document (AREVA 2016)
<ul style="list-style-type: none"> <ul style="list-style-type: none"> ○ land uses 	Section 2.4, Section 2.5.6 - Reference to the McClean Lake Operation, Environmental Performance Technical Information Document (AREVA 2016) for a description of biophysical environment and land uses.
<ul style="list-style-type: none"> <ul style="list-style-type: none"> ○ illustrations and maps of the facility in relation to the municipality 	Appendix A, Figure 1: McClean Lake Operation Location
<ul style="list-style-type: none"> • the purpose and description of the facility, including: 	Section 2.5.6 Reference to McClean Lake Operation, Facility Description Manual (Orano 2022)
<ul style="list-style-type: none"> <ul style="list-style-type: none"> ○ primary SSCs 	
<ul style="list-style-type: none"> <ul style="list-style-type: none"> ○ the building type and construction, including location of any hazardous building materials (e.g., asbestos, polychlorinated biphenyls) 	
<ul style="list-style-type: none"> <ul style="list-style-type: none"> ○ the building services (e.g., power, heating, ventilation, sewer, water, fire protection) 	
<ul style="list-style-type: none"> <ul style="list-style-type: none"> ○ laboratories and other hazardous handling areas 	
<ul style="list-style-type: none"> <ul style="list-style-type: none"> ○ the type, quantity and form of radioactive and hazardous materials managed, stored, produced or used during operation 	
<ul style="list-style-type: none"> <ul style="list-style-type: none"> ○ the design features used to reduce the spread of contamination and facilitate decontamination, dismantling and/or clean-up 	
<ul style="list-style-type: none"> • the anticipated post-operational conditions, including: 	-
<ul style="list-style-type: none"> <ul style="list-style-type: none"> ○ a summary of the shutdown process, including planned removal of stored inventories of hazardous or radioactive materials 	Section 5.1.1
<ul style="list-style-type: none"> <ul style="list-style-type: none"> ○ the predicted nature and extent of contamination remaining in the primary SSCs (in list or table format with reference to applicable illustrations) 	
<ul style="list-style-type: none"> <ul style="list-style-type: none"> ○ the predicted nature and extent of contamination on floors, walls and work surfaces, in ventilation systems, etc. 	

CNSC REGDOC-2.11.2 Decommissioning	McClean Lake Operation McClean Lake PDP Reference Location
○ an overview of the principal hazardous conditions anticipated	
○ the identification of any separate planning envelopes	Section 5.3
● the decommissioning strategy, including:	-
○ the final end-state objective	Section 2.3, 2.4, 2.5, 4.2.2
○ the rationale for:	-
▪ the decommissioning strategy selected	Section 5.1.2
▪ interim end states	Section 5.1.2, 5.5.1
▪ periods of storage with surveillance	Section 5.5.1
▪ any institutional controls	Section 5.4.2
○ the assessment of alternative strategies (or a rationale for why alternatives do not exist or do not warrant consideration)	Section 5.0
● the plan of the decommissioning work, including:	-
○ a work breakdown structure	Section 5.1.2, 5.5.1
○ a summary of the main steps for decontamination, dismantling and/or clean-up, and removal of each of the SSCs, preferably grouped into work packages	Section 5.1.2, 5.3, 5.5.1
○ for each work package, an identification of those types of activities that could pose a significant hazard to workers, the public or the environment	Section 4.6, 5.1.1
○ the role of existing operational standard procedures for radiation protection, hazardous materials handling, industrial safety, and environmental protection in managing hazards	Section 4.6
○ the specific activities for which additional protection/mitigation procedures will be required at the detailed planning stage (preparation for decommissioning phase)	Section 5.3
○ a summary of the final dismantlement of the structures	Section 5.1.1, 5.3
○ a conceptual schedule showing the approximate year of facility shutdown and the approximate sequencing and duration of the decommissioning work packages and, where relevant, storage periods	Section 5.5.1
● the hazardous monitoring and survey commitments, including:	-
○ a program for conducting periodic contamination surveys and the recording of contamination events during facility operation	Section 4.6.3, 4.6.8

CNSC REGDOC-2.11.2 Decommissioning	McClean Lake Operation McClean Lake PDP Reference Location
<ul style="list-style-type: none"> ○ a commitment to develop plans and protocols acceptable to the CNSC at the detailed planning stage for monitoring: 	Section 4.6
<ul style="list-style-type: none"> <ul style="list-style-type: none"> ▪ work hazards during decommissioning 	Section 4.6.4
<ul style="list-style-type: none"> <ul style="list-style-type: none"> ▪ personnel dosimetry 	Section 4.6.3
<ul style="list-style-type: none"> <ul style="list-style-type: none"> ▪ environmental emissions and effluents 	Section 4.6.2
<ul style="list-style-type: none"> <ul style="list-style-type: none"> ▪ materials, sites and structures to be cleared from regulatory control 	Section 5.3, 5.4.2
<ul style="list-style-type: none"> • a waste management strategy specifying: 	-
<ul style="list-style-type: none"> <ul style="list-style-type: none"> ○ the conservative quantities and characteristics of radioactive and chemically hazardous wastes expected to arise from the decommissioning (tied to specific work packages, if possible) 	Section 5.3, Table B1.3
<ul style="list-style-type: none"> <ul style="list-style-type: none"> ○ the anticipated final disposition of radioactive and chemically hazardous materials 	Section 5.3
<ul style="list-style-type: none"> <ul style="list-style-type: none"> ○ a commitment to segregate as much material as possible for reuse and recycling 	Section 5.0
<ul style="list-style-type: none"> • a commitment to prepare a DDP for CNSC acceptance prior to decommissioning 	Section 2.5.3
<ul style="list-style-type: none"> • a commitment to periodically review and update the PDP, in accordance with section 6.1 	Section 2.5.2
<ul style="list-style-type: none"> • the physical state of the facility at: 	-
<ul style="list-style-type: none"> <ul style="list-style-type: none"> ○ the end of operations (permanent shutdown state) 	Section 5.1, 5.1.1
<ul style="list-style-type: none"> <ul style="list-style-type: none"> ○ the start of decommissioning (stable state for decommissioning) 	Section 5.1.1
<ul style="list-style-type: none"> • the records required for decommissioning, including a description of the facility's operational records that will be maintained to periodically update the PDP and prepare the DDP(s) 	Section 4.6.8
<ul style="list-style-type: none"> • a public consultation plan, including a public information program and avenues for public participation as per the requirements and guidance of <i>REGDOC-3.2.1, Public Information and Disclosure</i> 	Section 2.6.4
<ul style="list-style-type: none"> • an Indigenous engagement plan as per the requirements and guidance of <i>REGDOC-3.2.2, Indigenous Engagement</i> 	Section 2.5.4
<ul style="list-style-type: none"> • the conservative cost estimate of decommissioning and a financial guarantee, as described in <i>REGDOC-3.3.1, Financial Guarantees for Decommissioning of Nuclear Facilities and Termination of Licensed Activities</i>, specifying: 	Section 6.0
<ul style="list-style-type: none"> <ul style="list-style-type: none"> ○ an estimate of the total present-value cost of the decommissioning 	Section 6.0

CNSC REGDOC-2.11.2 Decommissioning	McClean Lake Operation McClean Lake PDP Reference Location
<ul style="list-style-type: none"> ○ a reasonable basis for how cost estimates were derived 	Appendix B
<ul style="list-style-type: none"> ○ a description of how the required funds will be provided 	Appendix D

Appendix G: REGDOC-3.3.1 Concordance Table

The following table provides a cross reference to the suggested information for inclusion in a PDP, as outlined in the Canadian Nuclear Safety Commission REGDOC-3.3.1 Financial Guarantees for Decommissioning of Nuclear Facilities and Termination of Licensed Activities (CNSC 2021d), to the information included in the financial cost estimate provided as Appendix B.

CNSC REGDOC-3.3.1 Financial Guarantees for Decommissioning of Nuclear Facilities and Termination of Licensed Activities	McClellan Lake Operation McClellan Lake PDP Reference Location (Appendix B)
The cost estimate for decommissioning must address the cost of the following principal activities, if applicable:	-
• preparation for final shutdown	B1.4
• facility shutdown activities	B1.2 – B1.9
• decontamination and dismantling activities	B2.2, B2.3, B2.5-B2.11
• waste processing and storage, including used fuel	B1.3
• project management, engineering and site support	B1.4, B2.18
• site clean-up, landscaping and restoration (if required)	B2.2-B2.11
• long-term management, including disposal of radioactive waste and used fuel (if applicable)	B2.17-B2.20
• long-term monitoring and maintenance of the site and institutional control (if applicable)	B2.20
• miscellaneous expenditures	B1.1

Appendix H: Progressive Reclamation – Closure Documentation



November 17, 2017

Ms. Jana Lung
Environmental Project Officer, Uranium and Northern Operations
Ministry of Environment, Environmental Protection Branch
102 - 112 Research Drive
Saskatoon, SK S7N 3R3

Dear Ms. Lung:

Re: McClean Lake Operation – Submission of As Constructed Drawings for JEB Ore Pad Runoff Pond

Please find the attached as constructed drawings for the JEB Ore Pad Runoff Pond as per condition 5 of *Approval to Construct, Alter, or Extend Pollutant Control Facilities*, PC16-054.

During construction, modifications to the design were required to accommodate construction conditions, summarized in Table 1 and shown on the record drawings provided. The construction and the modifications to the design met the intention of the design.

Deviations from technical specifications included the following:

- Pond floor sub-grade compaction - Frozen ground conditions in the fall of 2016 created challenges for the contractor to meet compaction specifications for approximately 10% of the pond floor as noted on Drawing 403. Nominal compaction effort was applied to these areas. A risk assessment was conducted to assess the risk of installing liner over subgrade that had not achieved the compaction specification. The analysis concluded that the risks to liner performance was low and consisted of differential settlement in the sub-grade, potentially leading to increased liner maintenance. The risk of differential settlement was mitigated by placing frozen, screened till material in uniform thickness. Visual inspections of the performance of the lined area to date indicate no changes to the sub-grade condition and will continue to be monitored during annual liner inspections.
- Anchor trench backfill compaction - Frozen ground conditions created challenges for the Contractor to meet compaction specification in the anchor trench during the 2016 construction season as noted on Drawing 407. The anchor trench was backfilled with frozen material in 2016 and compaction specifications were not achieved. A risk assessment was conducted to compare several proposed methodologies for re-compaction including backfilling settled areas to the surface and compacting, excavating the top 300 mm of anchor trench and compacting, and excavating the entire anchor trench depth and compacting. All proposed methodologies considered nominal compaction as a minimum. The analysis concluded that the method of backfilling the settled areas to the surface and compacting posed the least amount of risk to the integrity of the existing liner during re-compaction and that this methodology would not adversely impact the intended function of the anchor trench. Settled areas of the anchor



trench were backfilled to surface and compacted during 2017 and observations have not identified any concerns to date. AREVA will continue to monitor the performance of the liner through annual visual inspections.

Should you have any questions, please contact myself or [REDACTED] or [REDACTED] at [REDACTED].

Sincerely,

[REDACTED] [REDACTED] [REDACTED] [REDACTED] [REDACTED]

[REDACTED]
General Manager
McClean Lake Operation

Attachment (1)

c: Mr. Salman Akhter (CNSC)
cnscc.ummd-dmucu.ccsn@canada.ca (CNSC)
ARC Distribution

gh



Table 1: Modifications to Design

Modification to Design	Description
Anchor trench location and geometry	The anchor trench alignment was shifted to 1.0m away from the interior crest; the bottom width of the anchor trench was reduced to 0.5m.
Boulder located in the northwest corner	A large boulder was identified in the northwest corner of the JEB Ore Pad Pond (approximately Station 0+235) within 150 mm of the finished design slope. A portion of the northwest corner slope was flattened to provide a minimum of 150 mm of material free of any stones larger than 40 mm below the bituminous geomembrane liner.
Boulder located in the anchor trench	A large boulder was identified on the interior vertical face of the anchor trench at approximately Station 0+310. The alignment of the interior vertical face was shifted further away from the crest to accommodate the large boulder. Two layers of non-woven geotextile were placed between the boulder and the bituminous geomembrane.
Wet well pipe	An existing 300 mm diameter HDPE pipeline was located between the wet well and the south pre-sedimentation pond at 10,723.65m N, 5,610.16m E, and 461.36 mASL. The outlet of the intake pipeline was fused over with HDPE liner. The intake pipeline was left in place and covered with compacted common fill.
Safety Berms	Safety berms were removed from the east and west crests of the pond. Vehicular traffic will not transit the east crest of the pond. A 1.8 m high safety berm was constructed along the west crest of the pond as part of the Waste Rock Pile Access Road construction (separate project).

AREVA
McCLEAN LAKE
ORE PAD POND
RECORD DRAWINGS

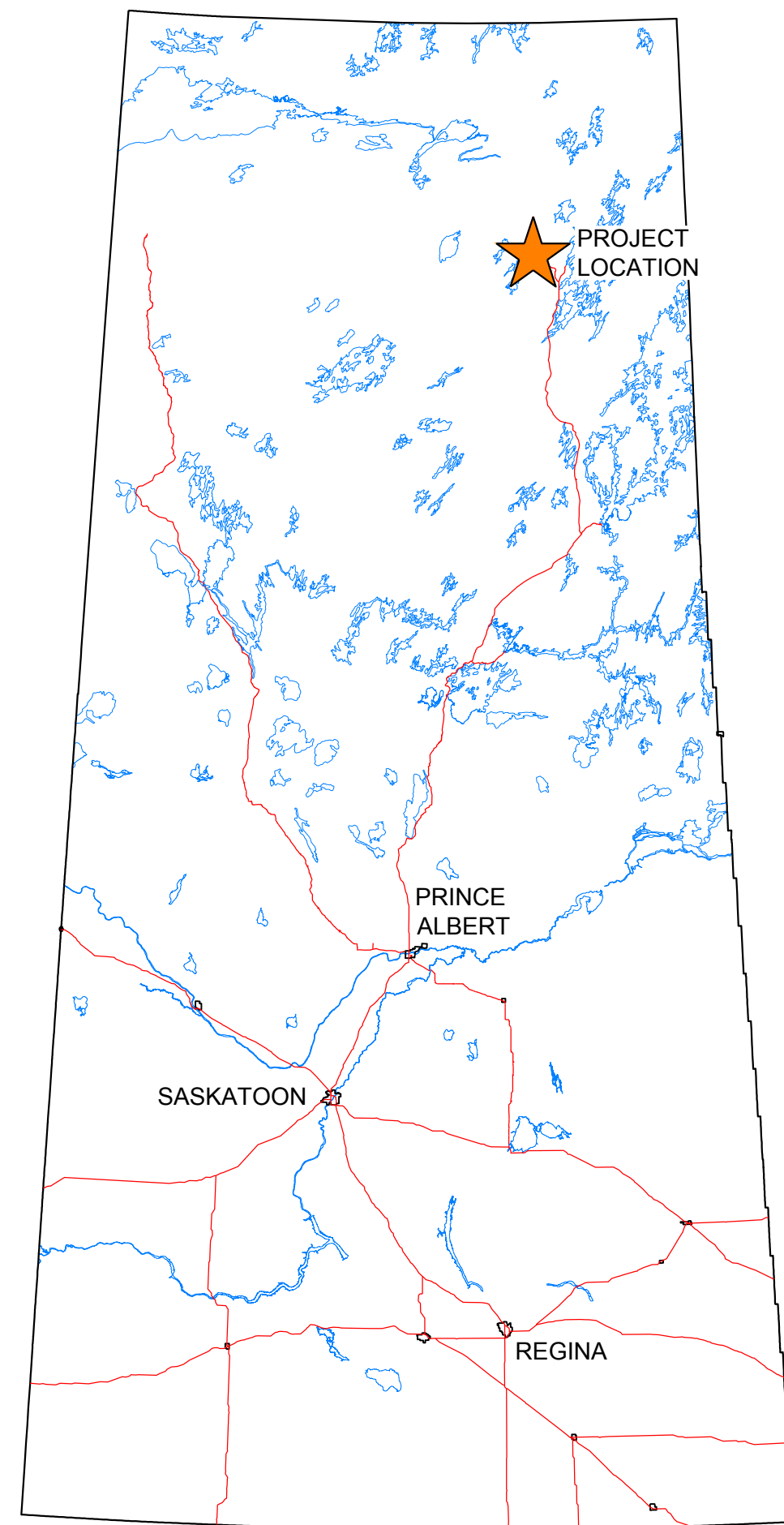

SASKATCHEWAN
 SITE VICINITY
 SCALE: NTS



SITE LOCATION
 SCALE: NTS

DRAWING LIST	
401	SITE GENERAL ARRANGEMENT PLAN
402	EXISTING INFRASTRUCTURE
403	ORE PAD POND GRADING PLAN
404	CROSS SECTIONS AND DETAILS
405	DETAILS
406	POND INLET SPILLWAY ORTHOGRAPHIC VIEW
407	DETAILS
408	SUMP DETAILS

Path: \\golder.aps\galsaskatoon\clients\AREVA\McClean Lake Operation\Figures\417371 - JEB Exp Mod\12000 Ore Pad Pond\DESIGN DRAWINGS\1 - File Name: 417371 - TITLE.dwg

SAMPLING / MONITORING

	BOREHOLE LOCATION
	BOREHOLE LOCATION (BY OTHERS)
	BOREHOLE LOCATION (PROPOSED)
	MONITORING WELL LOCATION
	MONITORING WELL LOCATION (BY OTHERS)
	MONITORING WELL LOCATION (PROPOSED)
	PIEZOMETER LOCATION
	PIEZOMETER LOCATION (BY OTHERS)
	PIEZOMETER LOCATION (PROPOSED)
	TEST PIT LOCATION
	TEST PIT LOCATION (BY OTHERS)
	TEST PIT LOCATION (PROPOSED)
	SOIL SAMPLE
	HAND AUGER
	INCLINOMETER LOCATION (EXISTING)
	INCLINOMETER LOCATION (PROPOSED)
	CPT LOCATION (EXISTING)
	CPT LOCATION (PROPOSED)
	WATER WELL DRY
	WATER WELL - ELOG
	WATER WELL FIELD VERIFIED
	WATER WELL PRODUCING
	INJECTION WELL

SURVEY SYMBOLS

	BENCHMARK
	CONTROL POINT
	FOUND IRON PIN (FIP)
	DESIGN GRADE

GENERAL FEATURES & SYMBOLS

	CULVERT LOCATION (SMALL DIAMETER)
	CULVERT LOCATION (LARGE DIAMETER)
	LIGHT STANDARD
	MANHOLE
	CATCH BASIN
	FIRE HYDRANT
	SIGN
	POWERPOLE
	BREAKLINE
	DEPOSITION LOCATION
	FLOW DIRECTION
	GRADE INDICATOR
	SLOPE DIRECTION
	WATER SURFACE
	SLOPE LABEL
	PROJECT LOCATION STAR

LINETYPES - UTILITIES

ABANDONED	EXISTING	
		FIBER OPTIC LINE
		NATURAL GAS LINE
		NON POTABLE WATER LINE
		OVERHEAD POWERLINES
		POTABLE WATER
		POWERLINE
		SANITARY LINE
		STORM DRAIN
		TELEPHONE LINE
		TRANSMISSION LINE
		UNDERGROUND LINE
		WASTE WATER
		WATER LINE

LINETYPES - PLAN FEATURES

EXISTING	NEW	
		FENCE LINE
		DITCH
		SILT FENCE
		STRAW BALE
		SWALE
		GUARDRAIL
		TREELINE
		CENTERLINE (ALIGNMENT)
		DESIGN LINES
		MAJOR CONTOUR
		MINOR CONTOUR
		PERFORATED PIPING
		PIPELINE
		SOLID PIPING
		CORE FACILITIES AREA
		RAIL LINE
		TMA BOUNDARY
		CUTOFF WALL
		WORKING LIMITS

LINETYPES - SECTIONS / DETAILS / PROFILES

	EXISTING GROUND		TOPSOIL
	NATURAL / ORIGINAL GROUND		WOVEN GEOTEXTILE
	FINISHED GRADE		GROUNDWATER
	HATCH BOUNDARY		SOLID PIPING
	HDPE LINER		PERFORATED PIPING
	LINER OTHER		
	NON-WOVEN GEOTEXTILE		
	PROJECTED EMBANKMENT		
	STRIPPED GROUND		
	SUBGRADE / SUBCUT		

HATCH PATTERNS

	ASPHALT
	CONCRETE
	COMMON FILL
	TRAFFIC GRAVEL
	FINE WELL GRADED GRAVEL
	SAFETY BERM FILL
	RIPRAP
	SCREENED TILL
	TOPSOIL
	PEAT
	CLAY
	GABION
	TAILINGS
	OVERBURDEN
	BEDROCK

GENERAL LABELS

	MATCH LINE
	DETAIL BUBBLE
	ALIGNMENT STATION LABEL
	DETAIL CALLOUT
	SECTION CALLOUT
	SECTION TITLE
	DETAIL TITLE
	VIEW TITLE
	REV CLOUD & CALLOUT
	ELEVATION LABEL
	BOREHOLE IDENTIFIER
	CPT IDENTIFIER
	CPT Q _v CURVE
	CONDUCTIVITY CURVE

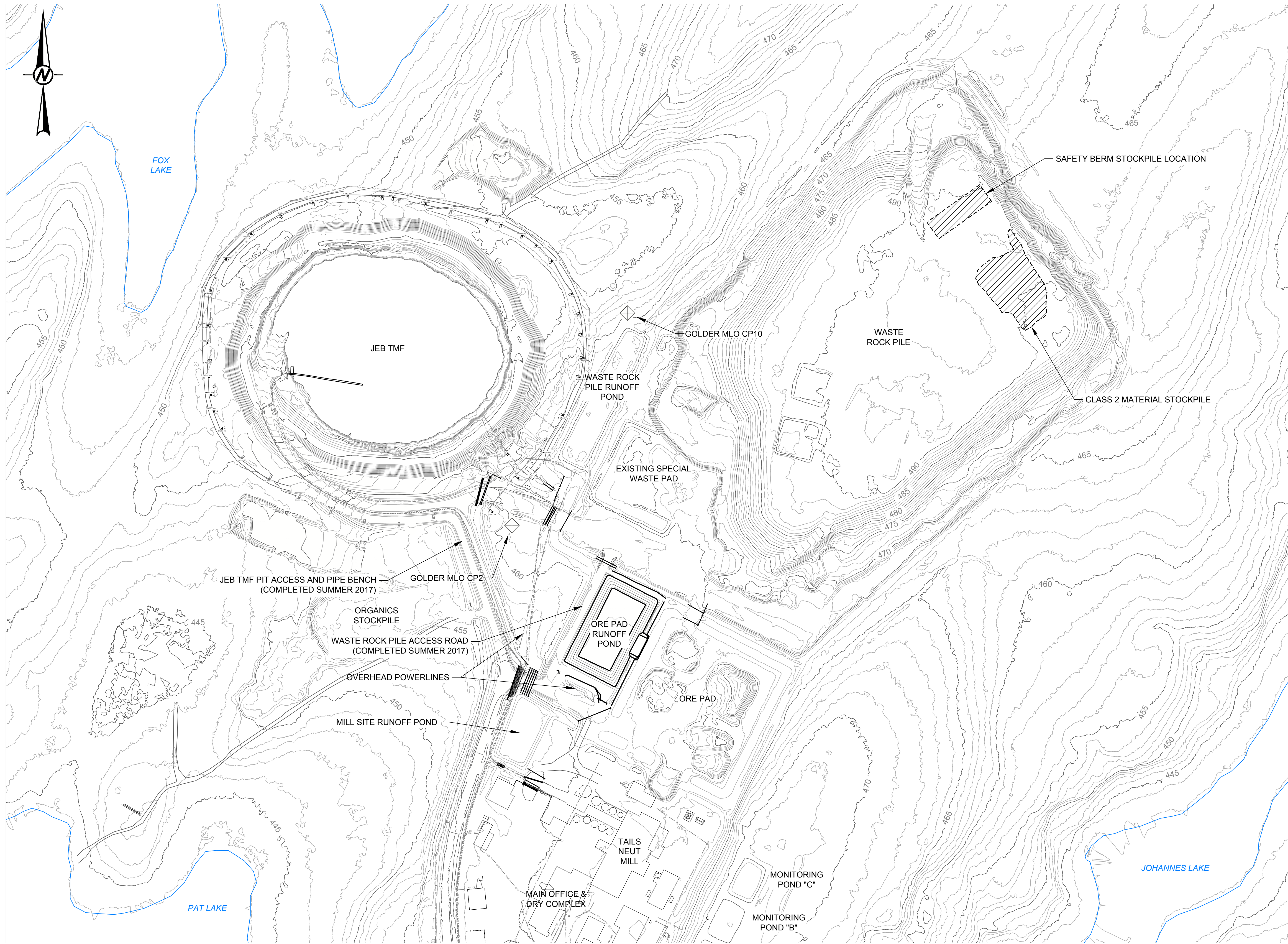

- NOTES**
1. TOPOGRAPHIC SURFACE GENERATED FROM LIDAR SURVEY, 2009 AND GOLDER RECORD OF CONSTRUCTION SURVEYS.
 2. CONTOURS SHOWN AT 1m INTERVAL.
 3. ELEVATIONS AND COORDINATES ARE REFERENCED TO LOCAL MINE COORDINATE SYSTEM.
 4. UNITS ARE METRES UNLESS OTHERWISE NOTED.

CONTROL POINT TABLE			
DESCRIPTION	NORTHING (m)	EASTING (m)	ELEVATION
GOLDER MLO CP2	10,949.17	5,485.63	461.42
GOLDER MLO CP10	11,253.05	5,650.67	459.21

RECORD DRAWINGS

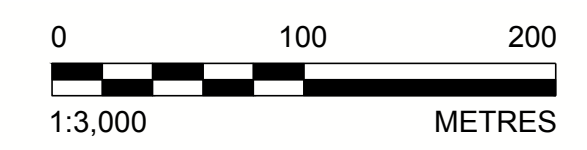

Path: \\golder-goldcorp\share\clients\areva\mcclean_lake_operations\figures\1417371 - JEB Exp Mod\12000 Ore Pad Pond\DESIGN DRAWINGS\1 - File Name: 1417371 - GA.dwg

Rev.	YYYY-MM-DD	DESCRIPTION	PREPARED	DESIGN	REVIEW	APPROVED
3	2017-11-06	RECORD DRAWINGS	JDS	JDS	KRC	GAM
2	2017-02-16	RECORD DRAWINGS	JDS	JDS	KRC	GAM
1	2016-06-27	ISSUED FOR CONSTRUCTION	JDS	JDS	KRC	GAM
0	2016-04-06	ISSUED FOR TENDER	JDS	JDS	KRC	GAM
A	2016-03-04	ISSUED FOR REVIEW	JDS	JDS	KRC	GAM

SEAL

CLIENT

CONSULTANT

AREVA

Golder Associates

SASKATOON OFFICE
1721 8th STREET EAST
SASKATCHEWAN
CANADA
(306) 665-7989
www.golder.com

PROJECT
**McCLEAN LAKE TAILINGS MANAGEMENT FACILITY
ORE PAD POND**

TITLE
SITE GENERAL ARRANGEMENT PLAN

PROJECT No. 1660781 PHASE 12000 Rev. 3 of 3 DRAWING 401

25 mm IF THIS MEASUREMENT DOES NOT MATCH WHAT IS SHOWN, THE SHEET SIZE HAS BEEN MODIFIED FROM ANSI D

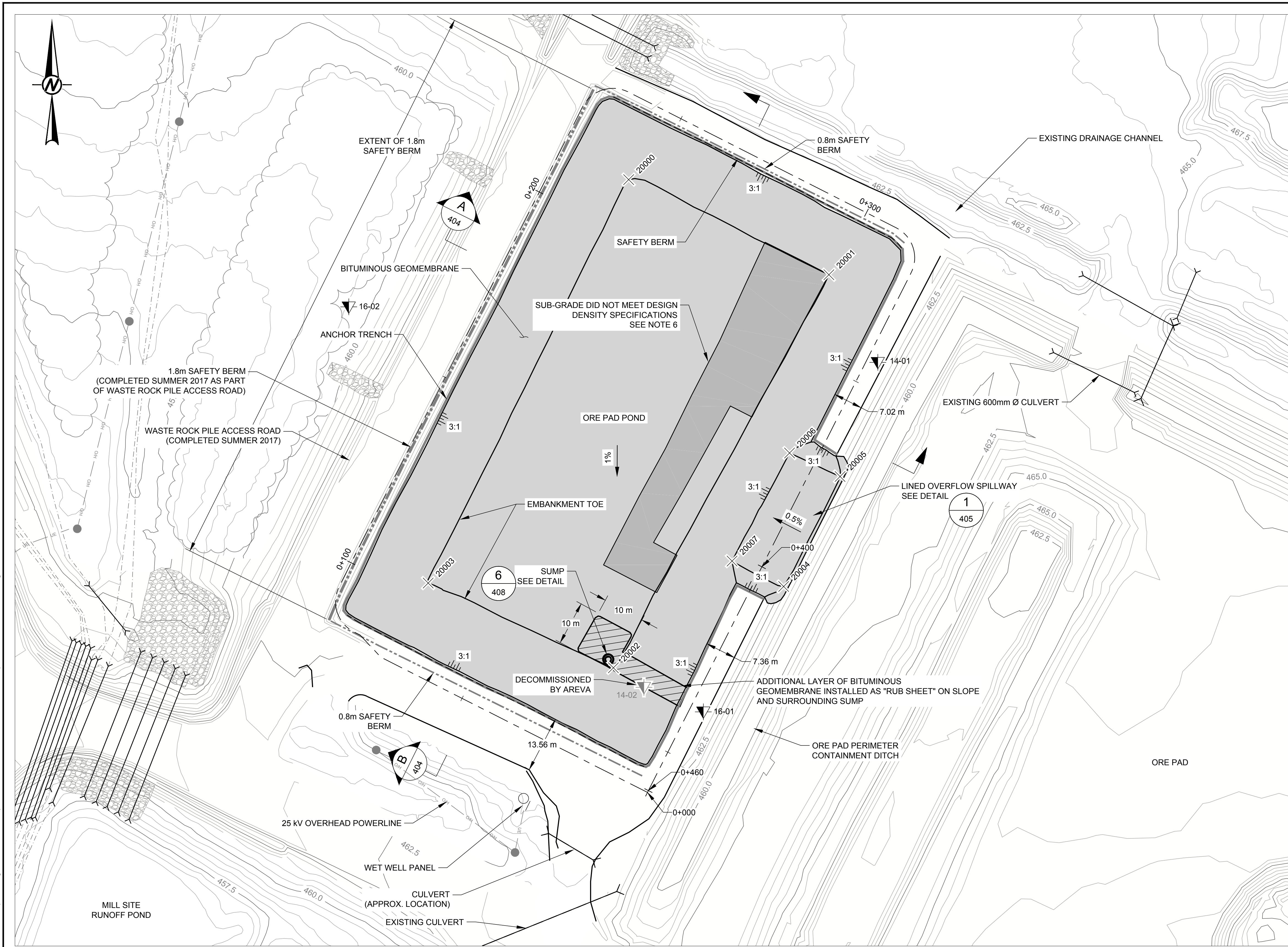

- NOTES**
1. TOPOGRAPHIC SURFACE GENERATED FROM LIDAR SURVEY, 2009. TOPO DATA PROVIDED BY AREVA IN DRAWING JEBSITE_C3D.DWG 2015-04-02, AND GOLDER RECORD OF CONSTRUCTION SURVEYS.
 2. CONTOURS SHOWN AT 0.5m INTERVAL.
 3. ELEVATIONS AND COORDINATES ARE REFERENCED TO LOCAL MINE COORDINATE SYSTEM.
 4. UNITS ARE METRES UNLESS OTHERWISE NOTED.
 5. LOCATION OF ALL UTILITIES SHOWN ARE APPROXIMATE.
 6. SEE AREVA WHAT-IF ANALYSIS "DEVIATION FROM QA/QC PLAN COMPACTION REQUIREMENT" DATED OCTOBER 27, 2016. VISUAL INSPECTIONS COMPLETED IN 2017 HAVE NOT IDENTIFIED ANY AREAS OF DIFFERENTIAL SETTLEMENT RESULTING IN TENSION STRESSES, FOLDS, OR SEPARATION OF THE BGM SEAMS AS A RESULT OF THE LOWER SUB-GRADE COMPACTION. AREVA WILL CONTINUE TO MONITOR THE PERFORMANCE OF THE BGM THROUGH ANNUAL VISUAL INSPECTIONS.

SETOUT TABLE			
POINT No.	EASTING (m)	NORTHING (m)	ELEVATION (m)
20000	5,629.00	10,858.39	458.47
20001	5,677.13	10,835.50	458.43
20002	5,625.33	10,740.95	457.32
20003	5,580.78	10,761.33	458.13
20004	5,666.27	10,760.50	461.99
20005	5,679.83	10,786.98	461.95
20006	5,667.68	10,792.61	461.88
20007	5,653.85	10,766.62	461.88

RECORD DRAWINGS

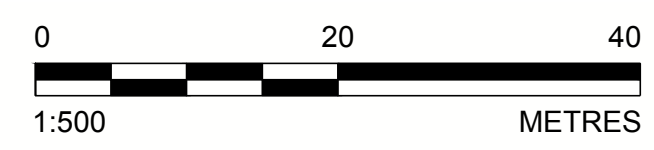

Rev.	YYYY-MM-DD	DESCRIPTION	PREPARED	DESIGN	REVIEW	APPROVED
4	2017-11-06	RECORD DRAWINGS	JDS	JDS	KRC	GAM
3	2017-06-28	2017 COMPLETION OF OUTSTANDING WORK	JDS	JDS	KRC	GAM
2	2017-02-16	RECORD DRAWINGS	JDS	JDS	KRC	GAM
1	2016-06-27	ISSUED FOR CONSTRUCTION	JDS	JDS	KRC	GAM
0	2016-04-06	ISSUED FOR TENDER	JDS	JDS	KRC	GAM
A	2016-03-04	ISSUED FOR REVIEW	JDS	JDS	KRC	GAM

SEAL

CLIENT

CONSULTANT

AREVA

SASKATOON OFFICE
1721 8th STREET EAST
SASKATCHEWAN
CANADA
(306) 665-7989
www.golder.com

Golder Associates

PROJECT
McCLEAN LAKE TAILINGS MANAGEMENT FACILITY
ORE PAD POND

TITLE
ORE PAD RUNOFF POND GRADING PLAN

PROJECT No. 1660781 PHASE 12000 Rev. 4 of 4 DRAWING 403

Path: \\golder-goldcorp\share\clients\areva\mcclean lake operation\figures\1417371 - EEB Exp Mod\12000 Ore Pad Pond\DESIGN DRAWINGS\1 - File Name: 1417371 - PLAN.dwg

25 mm IF THIS MEASUREMENT DOES NOT MATCH WHAT IS SHOWN, THE SHEET SIZE HAS BEEN MODIFIED FROM ANSI D

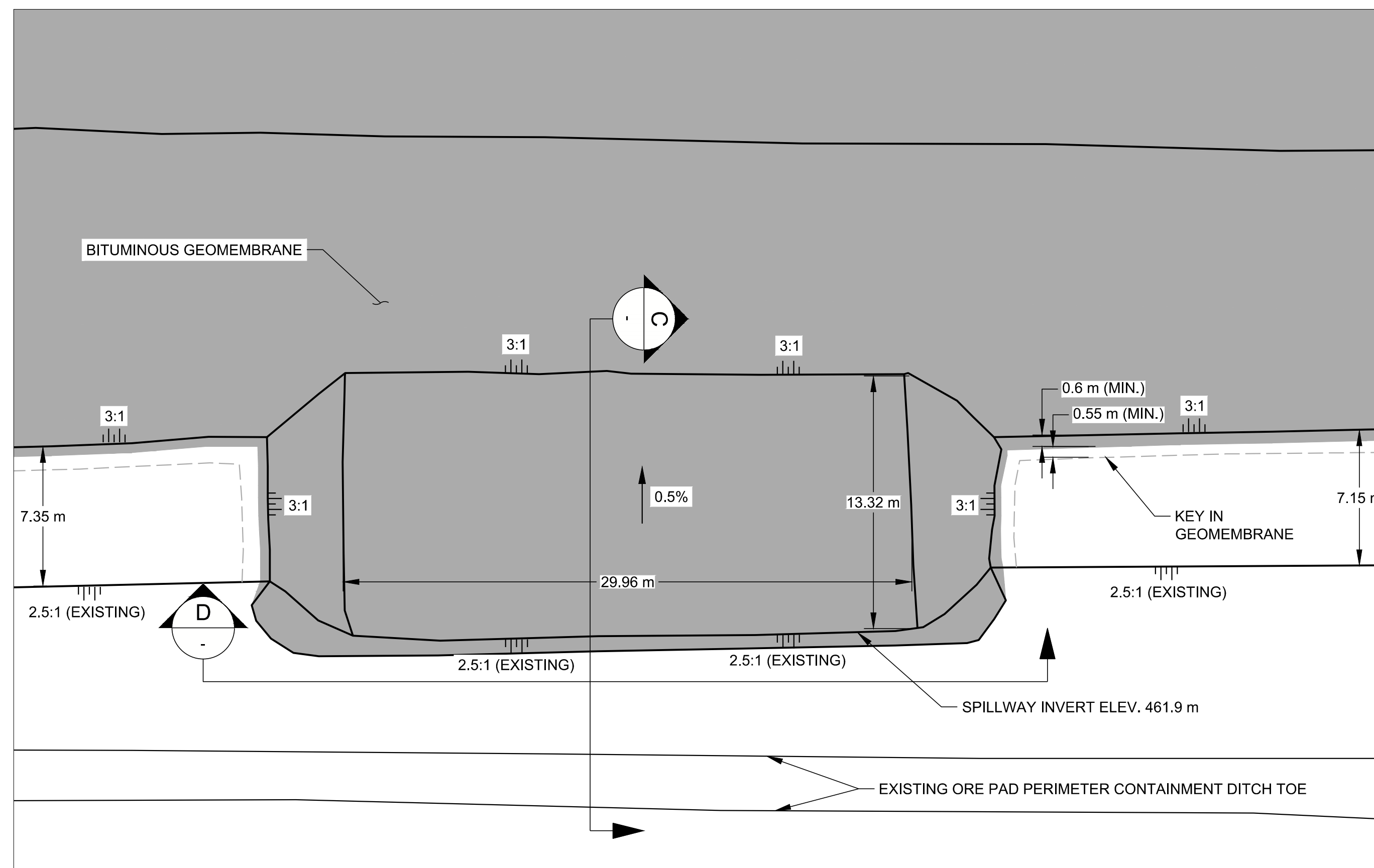

SCALE 1:200 **1** LINED OVERFLOW SPILLWAY DETAIL
403

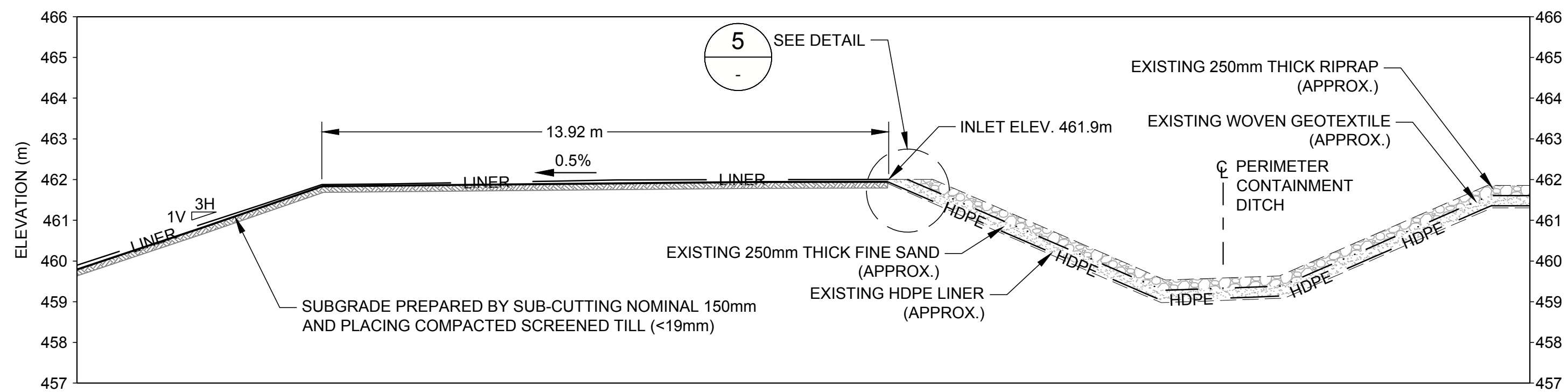

SCALE 1:100 **C** CROSS SECTION C
-

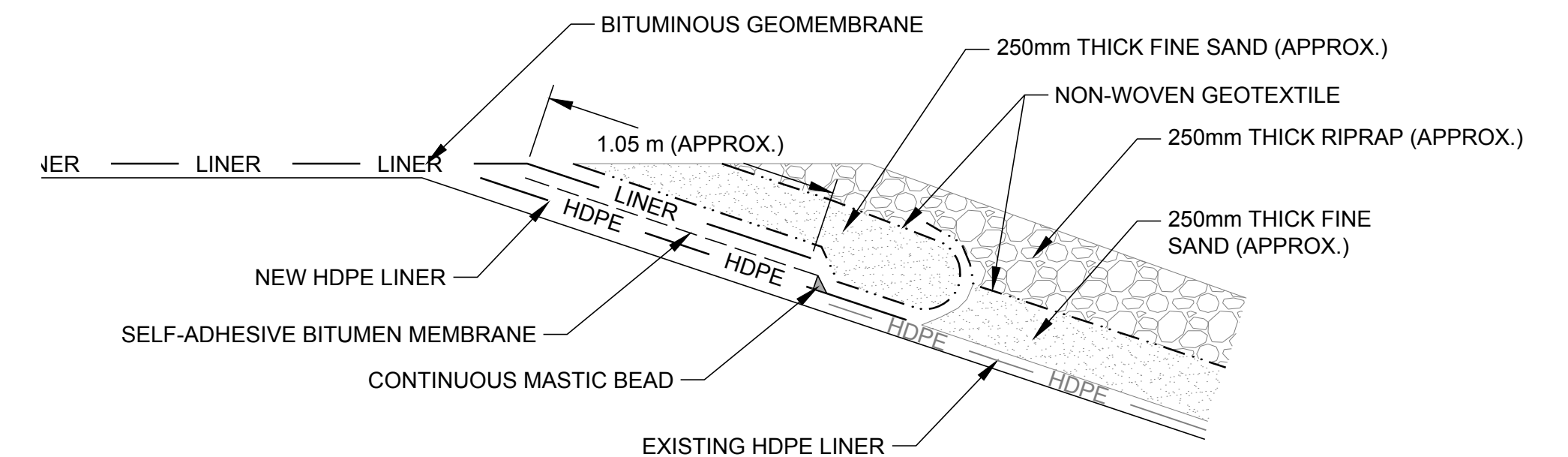

SCALE 1:20 **5** DETAIL
-

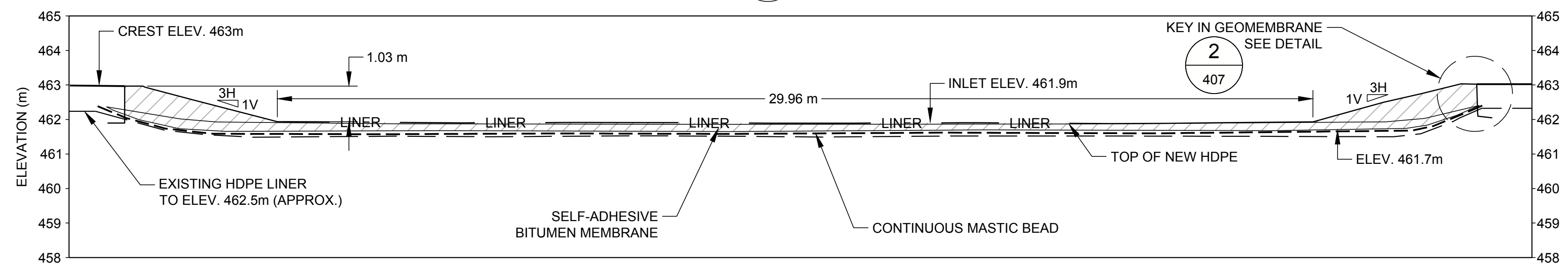

SCALE 1:100 **D** CROSS SECTION D
-

- NOTES**
- ELEVATIONS AND COORDINATES ARE REFERENCED TO LOCAL MINE COORDINATE SYSTEM.
 - UNITS ARE METRES UNLESS OTHERWISE NOTED.

RECORD DRAWINGS

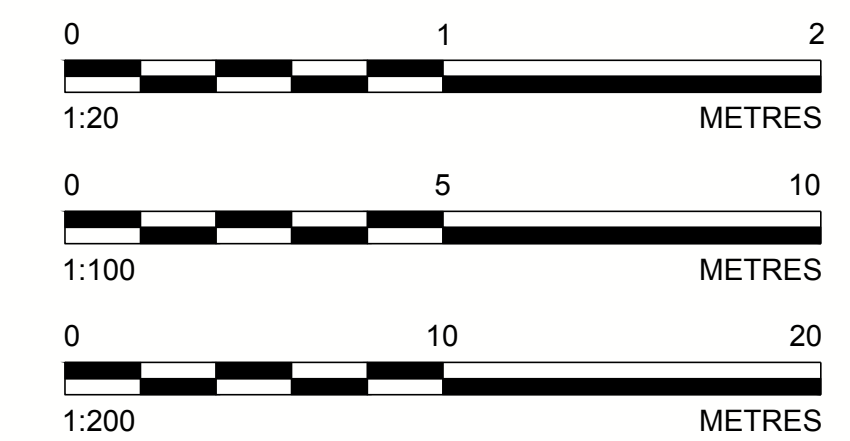

Path: \\golder-gis\gis\kassat\onfigs\Clients\SAREVA\SAREVA\McClean Lake Operation\Figures\1417371 - JEB Exp Mod\12000 Ore Pad Perimeter Design Drawings\1 - File Name: 1417371 - DETAILS.dwg

SEAL

CLIENT



CONSULTANT



SASKATOON OFFICE
1721 8th STREET EAST
SASKATCHEWAN
CANADA
(306) 665-7989
www.golder.com

PROJECT
McCLEAN LAKE TAILINGS MANAGEMENT FACILITY
ORE PAD POND

TITLE
DETAILS

Rev.	YYYY-MM-DD	DESCRIPTION	PREPARED	DESIGN	REVIEW	APPROVED
3	2017-11-06	RECORD DRAWINGS	JDS	JDS	KRC	GAM
2	2017-02-16	RECORD DRAWINGS	JDS	JDS	KRC	GAM
1	2016-06-27	ISSUED FOR CONSTRUCTION	JDS	JDS	KRC	GAM
0	2016-04-06	ISSUED FOR TENDER	JDS	JDS	KRC	GAM
A	2016-03-04	ISSUED FOR REVIEW	JDS	JDS	KRC	GAM

PROJECT No. 1660781 PHASE 12000 Rev. 3 of DRAWING 405

25 mm IF THIS MEASUREMENT DOES NOT MATCH WHAT IS SHOWN, THE SHEET SIZE HAS BEEN MODIFIED FROM: ANSI D

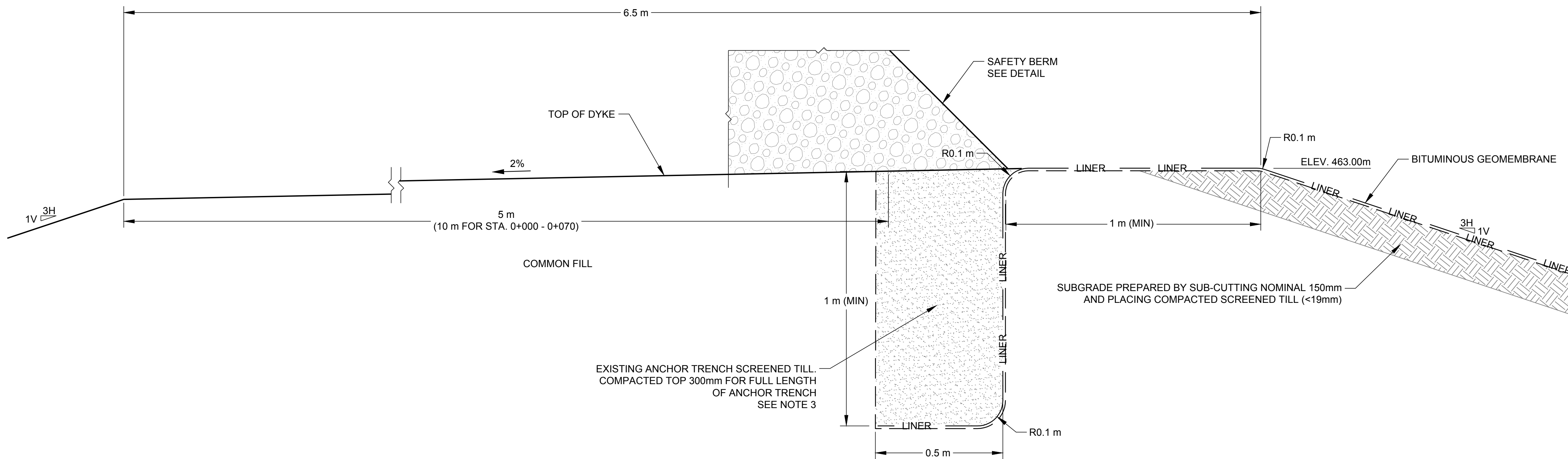

SCALE 1:10 **2** TYPICAL LINER KEY IN TRENCH DETAIL
404

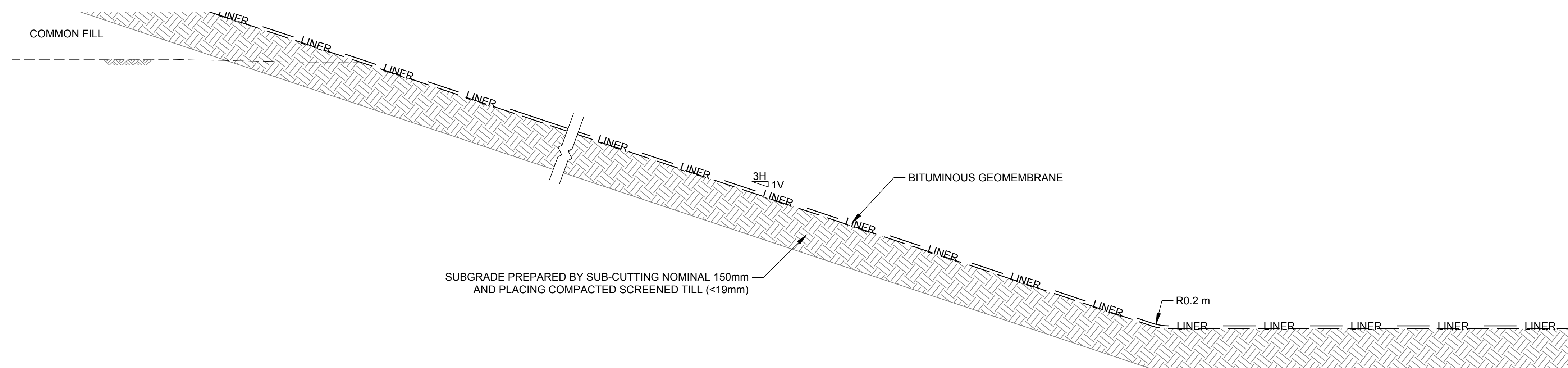

SCALE 1:10 **3** TYPICAL LINER POND TOE DETAIL
404

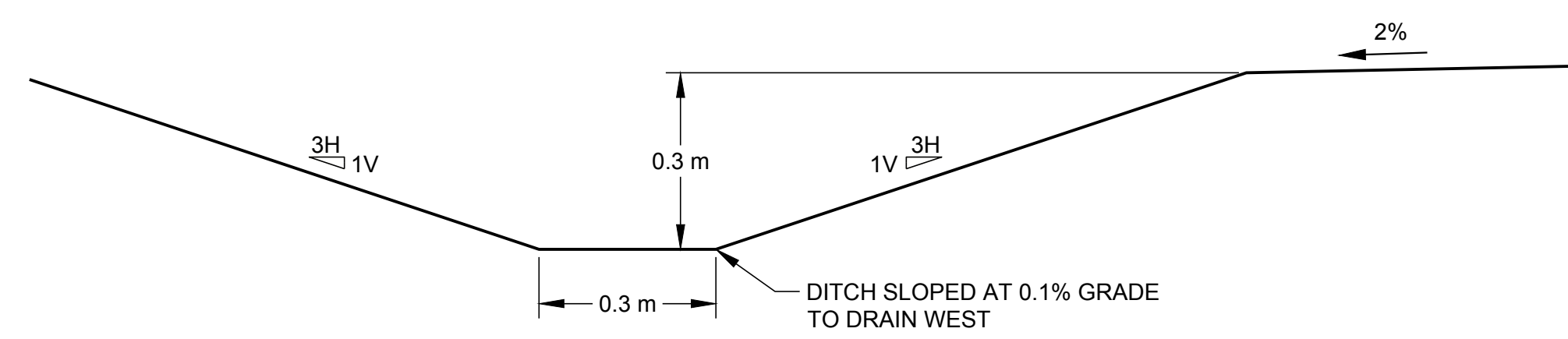

SCALE 1:10 **4** TYPICAL DITCH DETAIL
404

- NOTES**
- ELEVATIONS AND COORDINATES ARE REFERENCED TO LOCAL MINE COORDINATE SYSTEM.
 - UNITS ARE METRES UNLESS OTHERWISE NOTED.
 - SEE AREVA WHAT-IF ANALYSIS "281ML PMP POND - ANCHOR TRENCH COMPACTION REQUIREMENT" DATED MARCH 23, 2017. VISUAL INSPECTIONS COMPLETED TO DATE HAVE NOT IDENTIFIED ANY AREAS OF BGM PULLOUT FROM THE ANCHOR TRENCH. AREVA WILL CONTINUE TO MONITOR THE PERFORMANCE OF THE BGM THROUGH ANNUAL VISUAL INSPECTIONS.

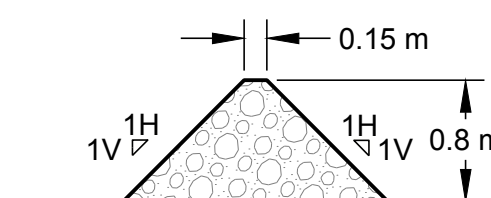

TYPICAL SAFETY BERM DETAIL
STA. 0+000 - 0+086 & 0+228 - 0+311
SCALE 1:50

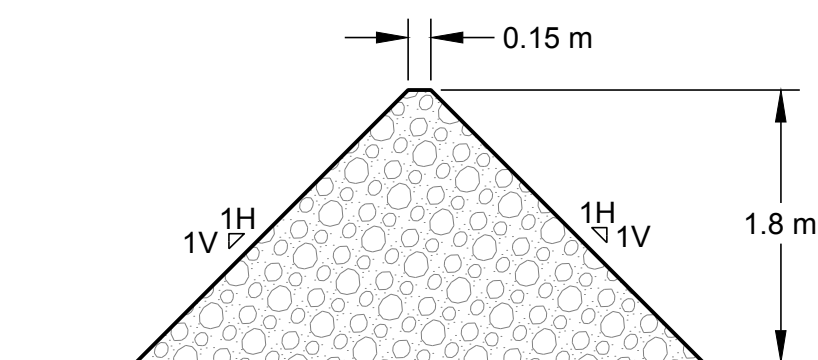

TYPICAL SAFETY BERM DETAIL
STA. 0+086 - 0+228 (COMPLETED AS PART OF WASTE ROCK PILE ACCESS ROAD)
SCALE 1:50

RECORD DRAWINGS

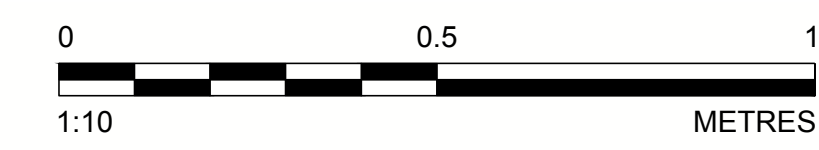

Rev.	YYYY-MM-DD	DESCRIPTION	PREPARED	DESIGN	REVIEW	APPROVED
5	2017-11-06	RECORD DRAWINGS	JDS	JDS	KRC	GAM
4	2017-06-28	2017 COMPLETION OF OUTSTANDING WORK	JDS	JDS	KRC	GAM
3	2017-02-16	RECORD DRAWINGS	JDS	JDS	KRC	GAM
2	2016-08-18	ISSUED FOR CONSTRUCTION	JDS	JDS	KRC	GAM
1	2016-06-27	ISSUED FOR CONSTRUCTION	JDS	JDS	KRC	GAM
0	2016-04-06	ISSUED FOR TENDER	JDS	JDS	KRC	GAM
A	2016-03-04	ISSUED FOR REVIEW	JDS	JDS	KRC	GAM

SEAL

CLIENT

CONSULTANT

AREVA

SASKATOON OFFICE
1721 8th STREET EAST
SASKATCHEWAN
CANADA
(306) 665-7989
www.golder.com

Golder Associates

PROJECT
McCLEAN LAKE TAILINGS MANAGEMENT FACILITY
ORE PAD POND

TITLE
DETAILS

PROJECT No. 1660781 PHASE 12000 Rev. 5 of DRAWING 407

Path: \\golder-goldcorp\share\clients\AREVA\McClean Lake Operation\Figures\1417371 - EEB Exp. Mod\12000 Ore Pad Pond\DESIGN DRAWINGS\1 - File Name: 1417371 - DETAILS.dwg

25 mm IF THIS MEASUREMENT DOES NOT MATCH WHAT IS SHOWN, THE SHEET SIZE HAS BEEN MODIFIED FROM: ANSI D

NOTES
 1. ALL DIMENSIONS ARE IN MILLIMETERS UNLESS SPECIFIED

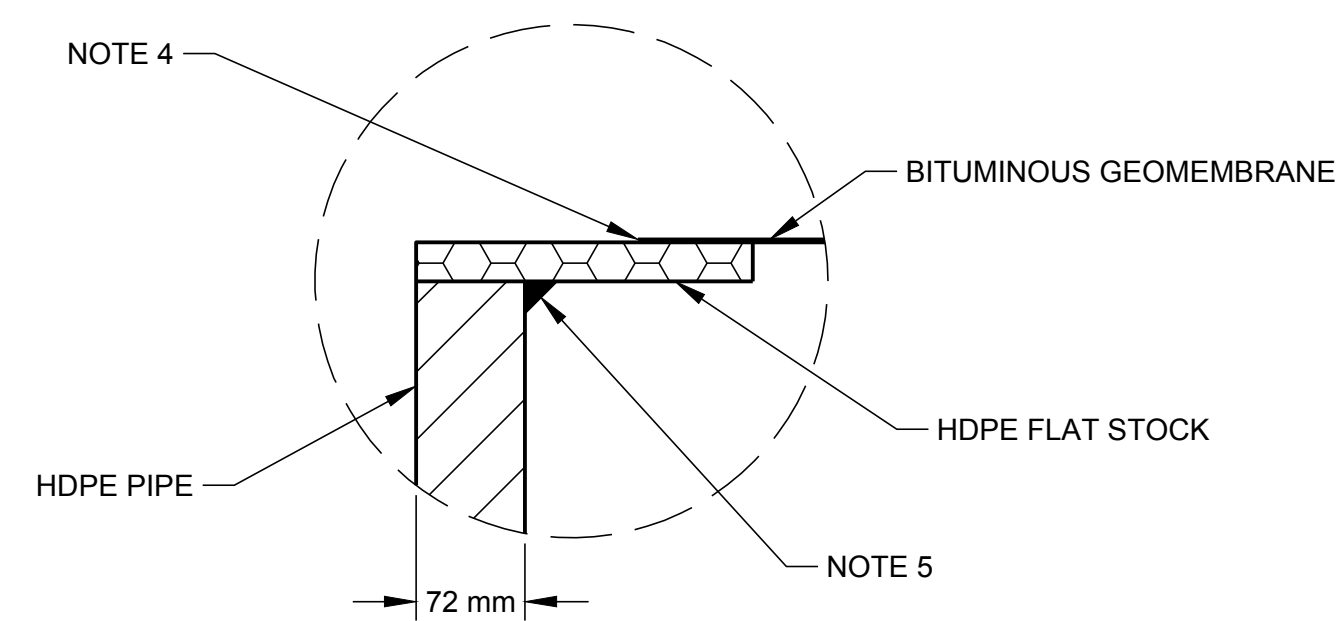
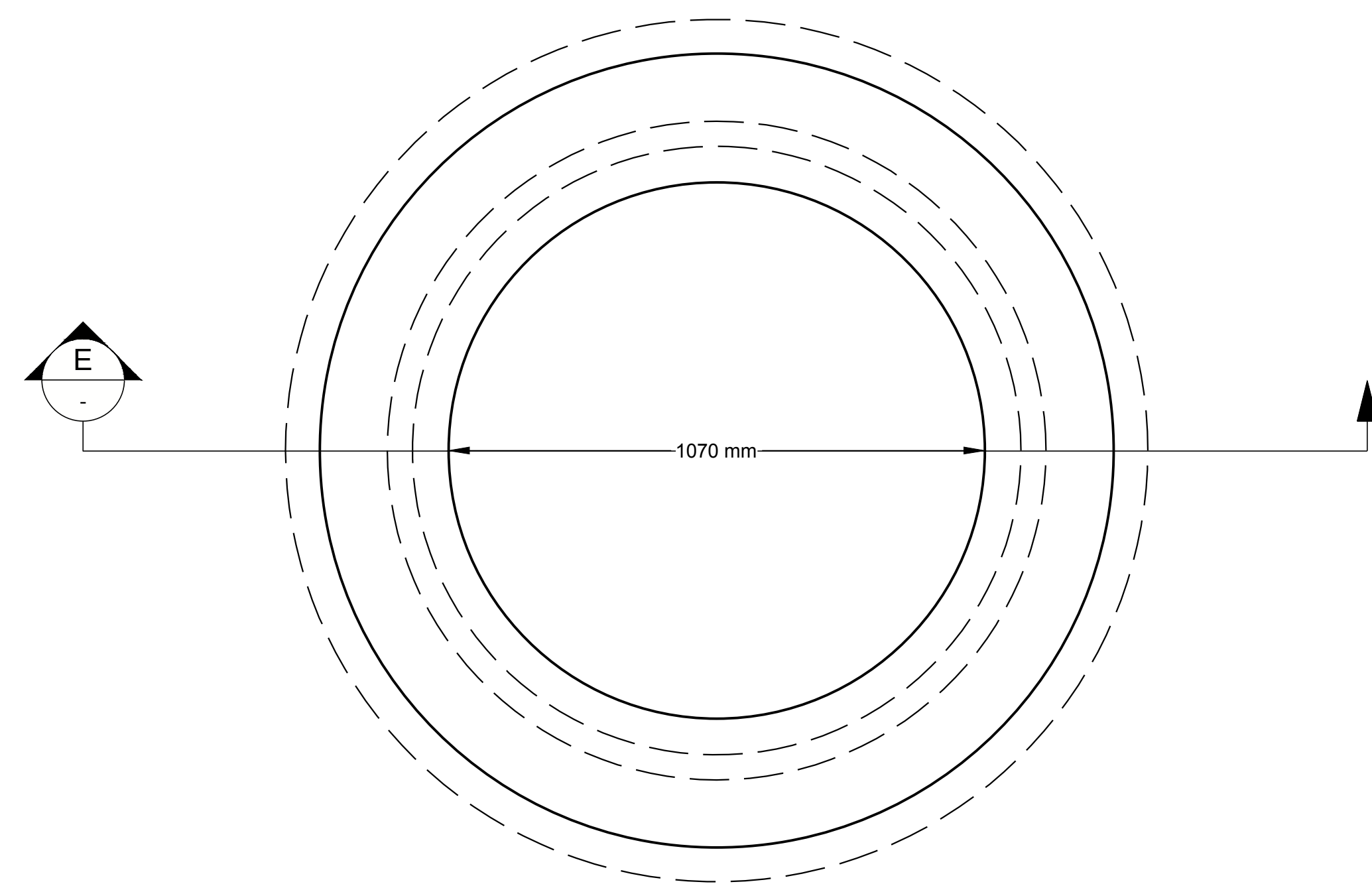

SCALE 1:5 **7** DETAIL

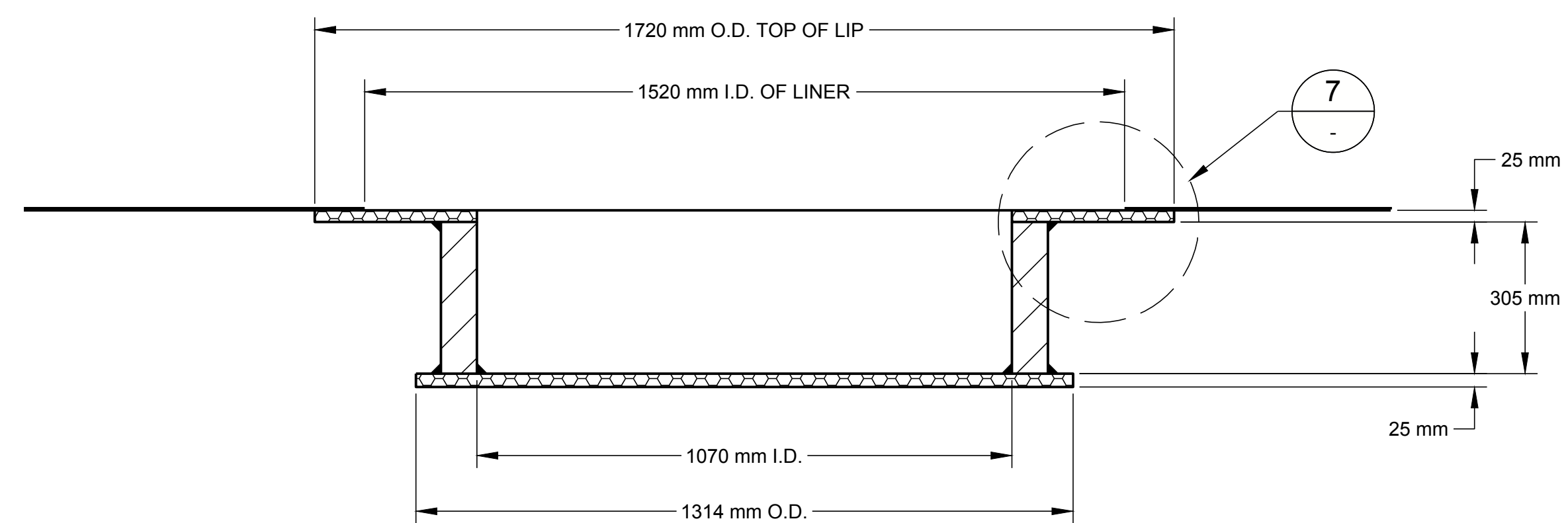

SCALE 1:10 **E** CROSS SECTION E

SCALE 1:10 **6** SUMP DETAIL
403

RECORD DRAWINGS

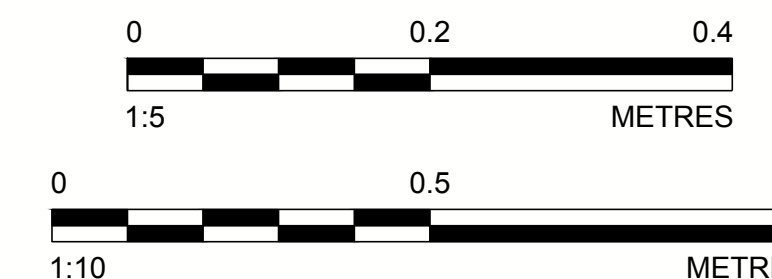

SEAL

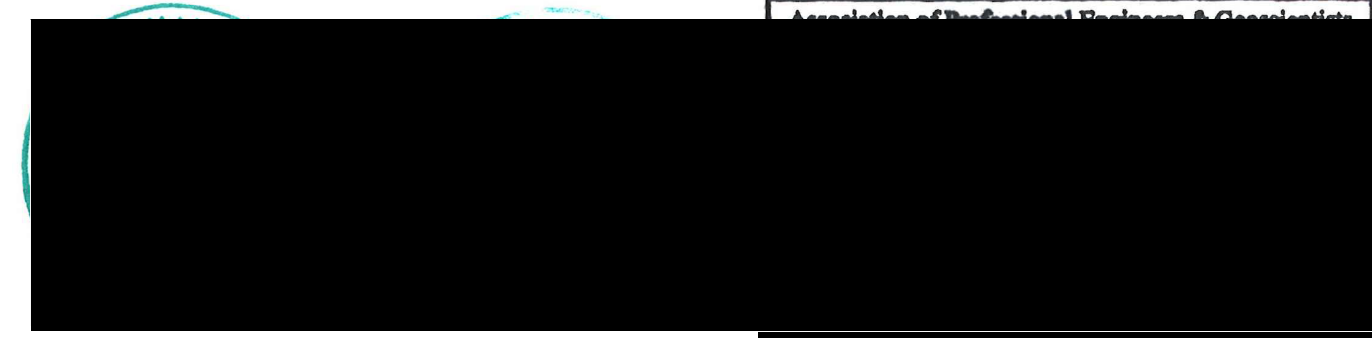

CLIENT



CONSULTANT



SASKATOON OFFICE
 1721 8th STREET EAST
 SASKATCHEWAN
 CANADA
 (306) 665-7989
 www.golder.com

PROJECT
 McCLEAN LAKE TAILINGS MANAGEMENT FACILITY
 ORE PAD POND

TITLE
SUMP DETAILS

Rev.	YYYY-MM-DD	DESCRIPTION	PREPARED	DESIGN	REVIEW	APPROVED
3	2017-11-06	RECORD DRAWINGS	JDS	JDS	KRC	GAM
2	2017-02-16	RECORD DRAWINGS	JDS	JDS	KRC	GAM
1	2016-06-27	ISSUED FOR CONSTRUCTION	JDS	JDS	KRC	GAM
0	2016-04-06	ISSUED FOR TENDER	JDS	JDS	KRC	GAM
A	2016-03-04	ISSUED FOR REVIEW	JDS	JDS	KRC	GAM

PROJECT No. 1660781 PHASE 12000 Rev. 3 of DRAWING 408

REPORT

AREVA Resource Canada Inc. McClellan Lake

Contaminated Landfill Relocation
McClellan Lake Saskatchewan
2016-8178-010 008F



December 2017

ISO 9001 and 14001 Certified | An Associated Engineering Company

CONFIDENTIALITY AND © COPYRIGHT

This document is for the sole use of the addressee and Associated Environmental Consultants Inc. The document contains proprietary and confidential information that shall not be reproduced in any manner or disclosed to or discussed with any other parties without the express written permission of Associated Environmental Consultants Inc. Information in this document is to be considered the intellectual property of Associated Environmental Consultants Inc. in accordance with Canadian copyright law.

This report was prepared by Associated Environmental Consultants Inc. for the account of AREVA Resource Canada Inc. McClean Lake. The material in it reflects Associated Environmental Consultants Inc.'s best judgement, in the light of the information available to it, at the time of preparation. Any use which a third party makes of this report, or any reliance on or decisions to be made based on it, are the responsibility of such third parties. Associated Environmental Consultants Inc. accepts no responsibility for damages, if any, suffered by any third party as a result of decisions made or actions based on this report.

REPORT

Table of Contents

SECTION	PAGE NO.
Table of Contents	i
List of Abbreviations	ii
1 Background	1
2 Discussion	1
2.1 Resident Engineering Services	1
2.2 Relocation	2
3 Summary and Conclusions	8
Closure	
4 References	1
Appendix A – AREVA Submission	
Appendix B – Photo Log	
Appendix C – Memos	
Appendix D – Figures	
Appendix E – Daily Monitoring Reports	
Appendix F – Laboratory Analytical Results	

List of Abbreviations

AE	Associated Engineering
AREVA submission	McClellan Lake Operation – Contaminated Waste Management – Notification/Application
CLC	Contaminated Landfill Cell
DCR	Daily Construction Report
Golder	Golder Associates Limited
JHA	Job Hazard Assessment
masl	metres above sea level
PBN	Pinehouse Business North
QM	Quantum Murray
SWTP	SUE Water Treatment Plant
TCL	Temporary Contaminated Landfill
TMF	Tailings Management Facility

1 Background

As described in the February 24, 2017 McClean Lake Operation - Contaminated Waste Management - Landfill Relocation – Notification/Application (AREVA submission-Appendix A) prepared by AREVA Resources Canada Inc. (AREVA) relocated their Temporary Contaminated Landfill (TCL) at the McClean Lake site. The TCL was relocated because the existing site fell within the extents of the future JEB Tailings Management Facility (JEB TMF) optimization and expansion. To allow for the optimization and expansion of the JEB TMF the TCL was relocated to a new permanent contaminated landfill within the Sue C/A Pit. A portion of the Sue C/A Pit was previously isolated to create the new permanent contaminated landfill site. The contractor selected to complete the TCL relocation project was Pinehouse Business North (PBN) and Associated Engineering (AE) was retained to provide full-time Resident Engineering Services for the duration of the relocation project. Site preparation for the relocation of the TCL began in June 2017 and relocation work began on July 18, 2017 and was completed on August 17, 2017. The contaminated landfill relocation was one of three projects proceeding in the summer of 2017. Golder Associates Ltd. (Golder) was responsible for the additional projects, TMF infrastructure decommissioning and the Tailings Pipe Bench Relocation. To allow for future construction of embankment for the TMF expansion, the TCL pods were backfilled after waste excavation and removal was completed. The supervision of backfilling of the TCL pods and QA/QC was conducted by Golder.

2 Discussion

2.1 RESIDENT ENGINEERING SERVICES

2.1.1 Scope

AE provided a proposal for site services during landfill relocation, the scope of Resident Engineering Services included:

- Provide resident engineering to monitor compliance with drawings and specifications.
- Measure or confirm measurement of relocation progress, and prepare daily monitoring reports.
- Coordinate communications with the Contractor, the design team, AE's Project Manager, and AREVA.
- Liaise with, and provide support to AREVA's construction management team, and other third party contractors to AREVA (Golder, PBN, QM) involved in the relocation process.
- Conduct soil sampling at the excavation limits of TCL pods.
- Maintain field drawings and document files at the TCL.

REPORT

In addition to the above scope, AE Resident Engineering staff also completed daily inspections of the ramp leading down to the dumping platform in the Sue C Pit (Sue C west ramp). The Sue C west ramp inspection involved inspecting the haul ramp for signs of degradation on the ramp, its side slopes, dumping platform, and berm between the new Contaminated Landfill Cell (CLC) and the Sue C Pit. Inspections were carried out once in every twenty-four-hour (24hr) period. Prior to the start of night shift, inspections were conducted every afternoon, typically between 2:00 pm to 3:00 pm. Once PBN initiated the night shift in conjunction with a day shift, inspections were conducted between 5:00 pm – 6:00 pm to coincide with PBN shift change.

The Job Hazard Assessment (JHA) created by PBN for the TCL relocation project indicated that a watcher must be present to monitor the AE personnel while the inspection is conducted. Therefore, the inspections were conducted before the day shift workers at the Sue C pit departed for the end of the day. In addition to the ramp inspection AE recorded the water level within the CLC daily.

At the June 6th pre-relocation meeting it was determined that AE would not bring survey equipment to site but indicated that AE may use survey equipment provided by another party or assist another party in their survey. As relocation progressed, it was determined by the AREVA project management team that responsibilities for final survey of the excavated pods and finished CLC surface would be assigned to Golder as they were completing survey tasks for the larger Tailings Pipe Bench Relocation project.

2.1.2 Resident Engineering Schedule

The proposed schedule of relocation included a complete TCL relocation in 2-weeks. As part of that schedule AE had intended to utilize one Resident Engineer for the duration of the project. Site conditions dictated that the TCL relocation would take longer than the scheduled two weeks, as a result AE worked with AREVA to schedule a cross shift for the Resident Engineer.

The first AE Resident Engineer arrived at the McClean Lake Operation on July 13, 2017. TCL relocation began on the afternoon of July 18, 2017. PBN maintained a day shift (6:00 am – 6:00 pm) until adding a night shift on July 21, 2017. Upon arriving to site, AE had maintained a 6:00 am – 6:00 pm shift, once PBN added a night shift, AE in consultation with the AREVA project management team adjusted the shift hours to 12:00 pm – 12:00 am. The second AE Resident Engineer arrived at the Mclean Lake Operation on July 27, 2017. The noon to midnight shift allowed inspection to encompass portions of both day and night shifts to ensure consistency between the two crews.

2.2 RELOCATION

2.2.1 Plan / Schedule

The AREVA submission suggested that overall, excavation activities were to occur from the east to west while maintaining two (2) active work areas to maximize excavation and backfilling/compaction activities while minimizing vehicle congestion. The report also suggested that one (1) excavator is capable of loading

7 trucks/hour at each active work area. Additionally, the report specified that one (1) compactor could process waste from fourteen (14) roll-off bins/hour.

PBN mobilized 5 roll off trucks for the TCL relocation and AREVA supplied the 14 roll off bins to minimize the potential for radiological contamination of the contractor equipment. Of the 14 roll off bins provided by AREVA, five were used in the TCL relocation project. Therefore, for the duration of relocation, one (1) excavator at the TCL and one (1) compactor at the new CLC were sufficient to handle the loads from the varying number of roll off trucks that were in use at any given time. A photographic log of site activities is included as Appendix B.

Due to the key issues highlighted below, the TCL relocation was completed in just over 4-weeks time.

2.2.2 Key Issues

Several issues presented obstacles throughout the duration of relocation. The two key issues were the elevated water level in the CLC and Sue C/A Pit and secondly, the number/condition of the roll off trucks.

Sue C/A Pit Water Elevation

The AREVA Submission indicated that the Sue C/A Pit lake was at an elevation of approximately 437 meters above sea level (masl) (fluctuating between 436 masl and 438 masl). It was anticipated that the Sue Water Treatment Plant (SWTP) would treat and discharge as much of the pit lake water as possible prior to commencement of the relocation project. Due to unforeseen downtime of the SWTP, as well as additional discharge of flows from Sue B to Sue C pits, and high spring runoff, water level was approximately 439 masl at the start of relocation. This resulted in the CLC base being submerged to a depth of approximately 2 metres. AE and the AREVA project management team took several steps to mitigate adverse impacts during relocation.

To control/contain floating debris, AREVA installed a silt fence (east-west across the CLC) roughly two thirds of the way north from the dumping platform. Compacting waste in roughly 2 m of water was noted as a potential concern. AREVA informed CNSC and SMOE of this situation and the proposed corrective actions on July 17, 2017. In this notification AREVA committed to compacting the waste on the platform and developing a safe work program in conjunction with the engineers and contractors.

AE and the AREVA project management team held a teleconference on July 18th, 2017 to address the risk presented by the high-water level. To mitigate risk to the operators, on July 21, 2017 AE prepared a Technical Memorandum titled "Test Procedure for Disposal of Temporary Contaminated Landfill Material at Sue C Contaminated Landfill" (Tech. Memo. Appendix C) in which AE suggested a test procedure to follow for the initial waste disposal. The test procedure involved installing waste rock to within approximately 300 mm of the water surface and then attempting to deposit TCL waste material in the 300 mm of water and continue to install waste material above the water level. However, higher than anticipated soil (glacial till overburden) mixed in with the contaminated waste from the TCL, PBN and QM, based on the observed contents of the TCL pods and QM's experience depositing water into water, opted to attempt dumping

REPORT

waste directly into the water contained in the CLC. During the week of July 21-26, 2017 informal meetings were held onsite between AREVA personnel and Rahim Ahmad of AE to assess compaction efforts.

AE was on site from July 13th to August 17th. AE monitored the Sue C Pit water elevation drop from a high of 439.378 masl on July 13, 2017 to a low of 438.514 masl on August 17, 2017. Using data provided by AREVA an as built drawing of the new contaminated landfill is presented as Figure 1 in Appendix D.

Roll-off Trucks

The relocation schedule was also affected by the roll off trucks used by PBN for the TCL relocation project. The 2017 AE Report recommended a schedule based on one excavator safely loading 7 trucks/hour. PBN mobilized 5 roll off trucks to site. Throughout relocation, the excavator averaged approximately 5 minutes/load and roll off trucks completed round trips (being loaded, driving to Sue C, dumping at Sue C, and returning to TCL) in approximately 1-hour. With five trucks in operation the excavator experienced up to 40 minutes of down time waiting for the trucks to return to the TCL. The average productivity rate was dependant on the amount of trucks in operation and ranged from 3 to 5 trucks per hour as compared to the original estimate of 7 trucks per hour.

In addition to fewer trucks, the roll off trucks mobilized to site were in relatively poor condition. When TCL relocation commenced on July 18th, only 3 of the 5 roll off trucks were in service. The fourth and fifth trucks were eventually commissioned but due to various maintenance issues and a shortage of drivers between July 18th and July 27th PBN was often forced to work with three (3) trucks. Maintenance issues included mechanical/engine problems, bin tarp mechanisms not able to cover the bin during transport, multiple tire failures, and headlight failures. Upon request of the contractor, AREVA approved the use of two (2) CAT 740D rock trucks to haul waste in addition to the five (5) roll off trucks. PBN revised their JHA to encompass use of the rock trucks for TCL relocation and commenced use of the rock trucks on August 1st. Approval for the use of rock trucks was contingent on covering the waste in the trucks with sand to prevent wind blown debris and daily pickup for wind-blown debris.

The condition and number of roll off trucks lead to significant loss in productivity and wasted man power. The night shift particularly suffered the consequences of truck down time, with one of the truck drivers often having no truck to drive due to maintenance issues.

2.2.3 TCL Material Composition

Contaminated waste excavated from the TCL generally consisted of a wide-ranging mix of material. Waste consisted of wires/cables, geotextiles, pipes of varying diameter and material, radiologically contaminated bags, metal objects of differing shapes and sizes, plastic barrels, old coveralls, etc. There were higher than anticipated amounts of soil mixed in with the waste excavated from the TCL which assisted the Contractor significantly with compaction efforts at the CLC. The higher amounts of soil added to the weight of the transported materials. When filled to top the weight was too heavy for roll-off trucks to operate fully which may have been a contributing factor to the maintenance issues experienced.

In addition to the general waste transported from the TCL to the CLC, there was also an assortment of large bulky items that could not safely be transported in the roll off bins. These oversized items were campaign hauled to the CLC and consisted of:

- Large concrete pads
- Dozer/excavator tracks
- Heavy metal piping with wide flanges
- Long lengths HDPE/PVC/Steel Pipe
- Metal tanks
- Pallets
- Other miscellaneous waste

Large sinkable items such as dozer tracks (that were free of oils and other liquids) were sunk into the Sue C Pit lake.

Based on the Golder survey of the excavation bases the calculated excavated volume of excavated material from Pods 1, 2, and 4 was approximately 19, 023 m³. Pod 3 contained no waste.

2.2.4 Communications

While on site, AE reported directly to AREVA. AE staff communicated daily updates with AREVA through the Daily Construction Reports (DCR). DCR's were submitted at the end of every shift and encompassed the daily activities in a chronological order. Key issues from each day were summarized in a separate section of the report to highlight items of higher importance. Each DCR also included key pictures from the day, these pictures captured the conglomerate of waste being excavated while also providing visual updates for AREVA project management in Saskatoon, DCRs are included in Appendix E. AE staff maintained verbal communication with AREVA on site project management staff throughout the daily shifts, matters requiring urgent attention were communicated over the AREVA radio, by phone or in person. Maintaining various lines of communication lead to efficient and effective resolutions thus minimizing engineering delays.

AE staff maintained a cordial working relationship with PBN staff. Quantum Murray (QM) led the TCL relocation, filling the superintendent role for the project. Therefore, AE staff looked to QM to provide insight on day to day activities and to answer any concerns. Conversely, QM directed enquiries to AREVA through AE, thus it was essential for AE to maintain close contact with the AREVA project management team. Twice daily informal site meetings were held between the Quantum Murray representative of each shift and AE staff. Since AE staff started work during the middle of the day shift, these meetings were held in the afternoons. AE staff held their informal meetings with the QM night shift immediately after the night shift safety meetings at 6:00 pm.

REPORT

2.2.5 Environmental Monitoring

The final excavation base in all Pods containing contaminated waste (Pods 1, 2, and 4) represented the maximum planned extent of excavation, and were approximately 0.5 m below the base of the waste in each of these TCL Pods. As part of the resident engineering services AE collected soil samples from the final excavation base of Pods 1, 2, and 4 (pod 3 was empty and did not require testing). Twenty-five (25) soil samples were collected between August 1 and August 14, 2017. The samples were collected to document site conditions and to characterize the condition of the soils that were left in place, following the TCL relocation. The sampling procedures that were followed are detailed in the Soil Sampling Plan memo prepared by AE with AREVA input and issued on August 1st, 2017 (Appendix C). Using survey data provided by Golder cross-sections of the excavated pods are shown as Figures 2-1 to 2-5 in Appendix D. Soil sampling locations are shown on Figure 3 in Appendix D.

All soil samples were field screened by AREVA using their Delta X-Ray Fluorescence (XRF) analyzer and XRF results are shown in Table 1 of Appendix F. Upon review of XRF results AREVA submitted 14 samples to the Saskatchewan Research Council (SRC) laboratory in Saskatoon Saskatchewan for analysis of total metals to determine constituent concentrations. The SRC analyzed the samples using Inductively Coupled Plasma – Mass Spectrometry (ICP-MS). SRC results are shown in Table 2 of Appendix F. The concentrations of arsenic and uranium are below the limits for the classification of the materials as waste rock as stated in the Waste Rock Technical Information Document (AREVA 2013). The waste rock classification concentrations limits for arsenic and uranium, are 75 ppm and 250 ppm, respectively. Residual metals concentrations are not considered a significant source of contamination. Any leaching of these metals into the shallow groundwater system would be less than when the TCL was present at this location and during operations the potential impacts to groundwater would be captured by the JEB TMF underdrain.

A comparison of results from the AREVA XRF and SRC results for arsenic and uranium indicated that there was a good correlation between the reported metals concentrations from these two methods and that the XRF is a valuable field screening tool for metals constituents.

The results of the soil sampling indicate that a residual risk assessment would be unnecessary.

2.2.6 Contractor Performance

Staffing

Overall, the contractor performed their responsibilities in a satisfactory manner. PBN employed competent equipment operators who completed work in as safe a manner as reasonably possible. PBN enlisted QM to assist them with the TCL relocation project and to provide them with valuable industry knowledge relating to landfill relocations. Additionally, AREVA enlisted the help of a third-party consultant familiar with landfill construction and operation. The third-party consultant provided on-site training to the PBN operators on how to safely operate the compactor purchased to complete the landfill compaction. Together, QM and the

third-party consultant helped guide the PBN operators in completing the relocation in a safe and efficient manner.

For approximately the first week of the TCL relocation, PBN only had one mechanic on site. Once night shift commenced, there was initially no mechanic for the night shift crew. Lack of a mechanic for the night shift lead to loss of productivity due to equipment maintenance issues that could not be addressed until the mechanic began his shift the following morning.

Delays

The originally estimated 2-week completion schedule for the TCL relocation project was ultimately extended and the TCL relocation work was completed in just over 4-weeks time. Although PBN employed competent staff, the key factors leading to a late completion date were related to equipment and site conditions. As stated earlier in the report, the Contractor mobilized less equipment than the AREVA submission indicated. Additionally, the roll-off trucks commissioned for the work were in relatively poor condition to complete the work. Less equipment coupled with regular equipment maintenance issues lead to loss of productivity. Subsequently, once the original completion deadline slipped, attempts were made to speed up the relocation project by utilizing rock trucks in addition to the roll off trucks. Due to the additional weight added by the unexpectedly high soil and gravel content in the pods roll-off trucks had to be loaded with a lower volume to reduce weight leading to an increase in the number of required trips and a delay in schedule. Additionally, there was a short initial delay while the higher than anticipated water level was being addressed in the JHA at project start-up.

Ultimately, AE was not tasked with completing survey of the excavated extents of the TCL pods. However, based on visual inspection of the excavated pods, it appears that the originally estimated depths, extents, and volumes of the pods were relatively accurate. The original estimated volume of the pods to be excavated and relocated was 17,080 m³ and the estimated volume of the pods that was excavated and relocated is 19,023 m³. As such, it can not be concluded that delays were a result of greater than anticipated waste quantities.

3 Summary and Conclusions

AE provided Resident Engineering Services for the duration of the TCL relocation project. The relocation commenced on July 18th, 2017 and was substantially completed by August 17th, 2017. Waste was hauled from the TCL to the new permanent CLC at the Sue C/A Pit. As part of the resident Engineering Services, AE provided daily reports to the AREVA project management team to provide daily relocation updates. In addition, AE also assisted AREVA by preparing a sub-soil sampling memo to help plan the sub-soil testing procedure at the TCL. AE worked with the Contractor towards the successful completion of the project and ensured communication between the Contractor and AREVA's project management team. Although not confirmed by survey through AE, visual inspection indicated that the pod extents were relatively similar to those anticipated.

REPORT

Closure

This report was prepared for the AREVA Resource Canada Inc. McClean Lake to summarize site activities for the duration of the TCL relocation project undertaken at the AREVA McClean Lake Operation in Northern Saskatchewan.

The services provided by Associated Environmental Consultants Inc. in the preparation of this report were conducted in a manner consistent with the level of skill ordinarily exercised by members of the profession currently practicing under similar conditions. No other warranty expressed or implied is made.

This report was prepared by:
Associated Environmental Consultants Inc.



Project Engineer



This report was reviewed by:
Associated Environmental Consultants Inc.

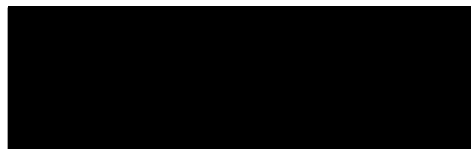

Environmental Scientist

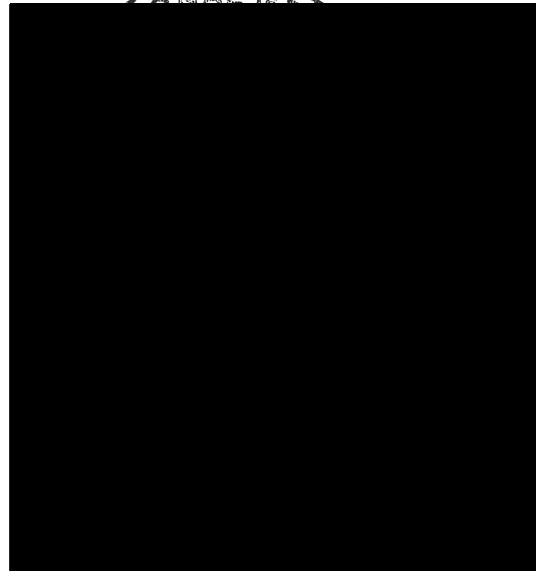

ASSOCIATED ENGINEERING	
QUALITY MANAGEMENT SIGN-OFF	
Signature:	<i>gent</i>
Date:	12-13-17

4 References

AREVA Submission 2017. McClean Lake Operation Contaminated Waste Management Regulatory Notification/Application, AREVA Resources Canada. February 2017.

AREVA Resources Canada Inc. 2013. Waste Rock Management Technical Information Document. June 2013.